

Task 62: Wear in Engines Using Alternative Fuels

The influence of fuel H/C ratio on engine wear

Rune Christensen, Jesper Schramm
Technical University of Denmark

Fanny Langschwager, Ulrike Schuemann, Bert Buchholz
University of Rostock

September / 2024

Summary / Abstract

Water is suspected to be associated with increased engine wear. This was the background for a more detailed experimental program with the a motored combustion engines with different combinations of charge gases, simulating gases with excess hydrogen content as seen in many alternative fuels. The purpose with our experiments was to relate water content in the engine intake charge to wear metals in the lubricant and to water condensation on the cylinder liner. This latter part was investigated with a newly developed sensor on the cylinder liner.

The experiments indicated that the lubricant has a strong influence on the wear damage caused by the water interaction at the cylinder liner. The less polar the lubricant is, the more protective it is against the liner corrosion caused by water condensation.

Furthermore, it was found that water concentrations in the cylinder gases around 20 % is a magic limit where the wear is speeding up dramatically. This is unfortunately in the range of exhaust water concentrations for very relevant alternative fuels like ammonia and methanol.

Authors

Denmark:

Rune Christensen, Jesper Schramm

Germany:

Fanny Langschwager, Ulrike Schuemann, Bert Buchholz

Content

Background	4
The test facility	6
Oil analysis	8
Water on liner (WOL) measurements	9
Data interpretation	10
Results	11
Conclusions	14
References	15

Background

As mentioned earlier in Task 62 water is suspected to be associated with increased engine wear. An investigation meant to investigate corrosion of cylinder wear in marine engines discovered that water was the main reason for wear, despite the sulfuric acid was the main concern in the investigation [1]. This was the background for a more detailed experimental program with the same engine in the present investigation. The purpose with our experiments was to relate water content in the engine intake charge to wear metals in the lubricant and to water condensation on the cylinder liner. This latter part was investigated with a newly developed sensor on the cylinder liner.

The H/C ratio of the fuel is important since a higher H/C ratio means higher water content in the exhaust. Many alternative fuels have an increased H/C ratio, so this is of special concern with these fuels. Table 1 shows the H/C ratio of the most relevant alternative engine fuels as well as the exhaust water content at stoichiometric combustion with air. For hydrocarbon fuels the exhaust water content is calculated from the stoichiometric reaction:

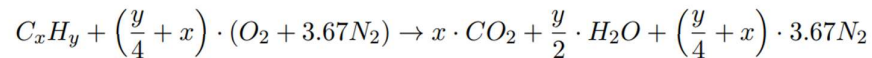

For ammonia and hydrogen the following equations are used:

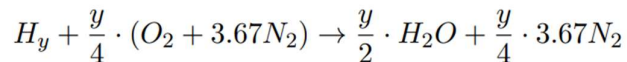
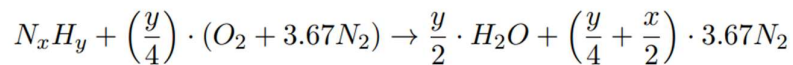

Fuel	Composition	H/C ratio	Exhaust water content
		mole/mole	Vol-%
Diesel	C ₁₂ H ₂₃	1,91	12,7
Methanol	CH ₃ OH	4	23,1
Methane	CH ₄	4	19
Ammonia	NH ₃	∞	31,1
Hydrogen	H ₂	∞	34,7

Table 1. H/C ratio and exhaust water content of selected alternative fuels at stoichiometric combustion.

The exhaust water content varies with air/fuel ratio applied. In Figure 1 the variation with the applied excess air fuel ratio is shown for ammonia, methanol and diesel.

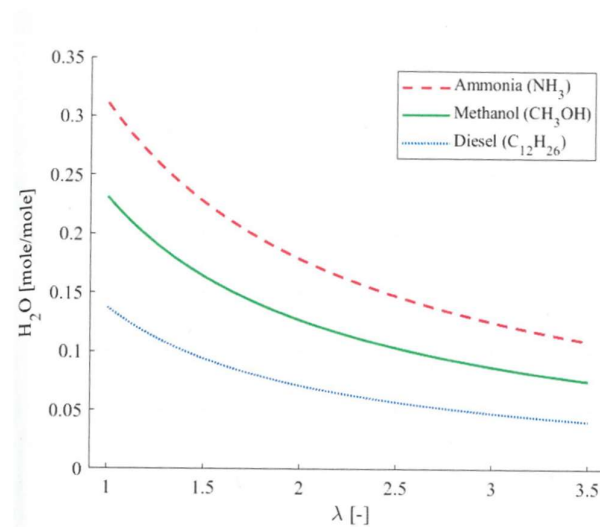

Figure 1. Variation in the exhaust water content as a function of excess air ratio (λ) for selected fuels. The water content is shown as H₂O moles/mole of exhaust, which is the same as volume-%/100.

It is obvious that the exhaust water content can be much higher when applying alternative fuels, compared to diesel exhaust.

The test facility

A modified two-cylinder and four-stroke BUKH DV24 diesel engine is used in this work with the specifications listed in Table 2. The test facility is schematically illustrated in Figure 2 and described in the following.

The test engine is designed to run at a speed significantly faster than a marine propulsion engine. In order to have a better comparison with the phenomena found in a slow moving marine engine it is necessary to run the engine without combustion using an electric motor. The engine is run at about 98 RPM instead of 1000-3600 RPM which is typical for this engine. This is done to ensure the charge gas is replenished at a similar rate to a two stroke marine propulsion engines which typically run at about 50 RPM. The lack of combustion greatly simplifies the test setup, as it removes a number of hard to control parameters. Because there is no combustion, it is necessary to heat the engine using an electric heater. The engine is heated using the cooling channels using a base oil. The water pump is replaced with an electric pump that circulates the oil through a PID controlled heater, as well as the engine. Oil is used in order not to shortcut the electrode from the backside. Several measures are applied in order to minimize the running time needed to accumulate wear. The oil volume in the sump is minimized by converting to a dry sump, this allows for a smaller oil volume (600ml vs 2.5L) having a smaller diameter sump, allowing the sufficient oil height for the pump, at a smaller volume. This will in turn mean a small amount of wear will have a greater impact on the concentration of metals in the oil. Meaning the engine needs to be less worn to get a significant result, allowing for more testing before an engine rebuild.

Working principle	Four stroke
Number of cylinders	2
Bore/stroke/connecting rod	85 mm/85 mm/159.8 mm
Swept volume per cylinder	482 cm ³
Geometric compression ratio	18.5:1

Table 2. BUKH DV24 engine specifications.

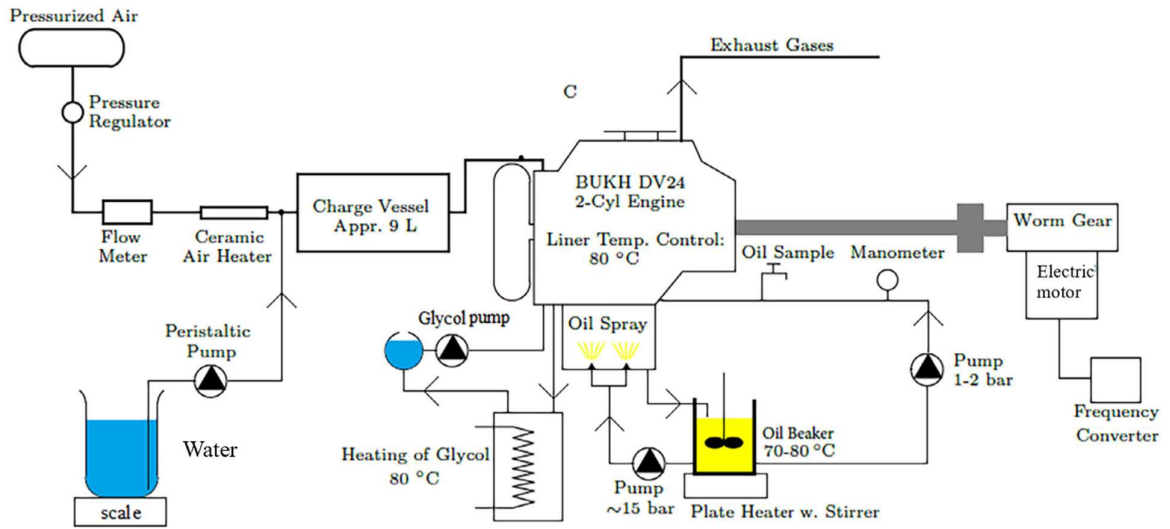

Figure 2. The test facility.

Samples of the oil are collected at the oil sample tap and analyzed in the chemical lab.

Oil analysis

During the investigations two different lubrication oils were used:

- Oil 1: 15W-40 mineral oil
- Oil 2: 10W-40 fully synthetic oil

A semi synthetic oil is a mix of fully synthetic oil and mineral oil.

Samples of the oil are collected at the oil sample tap and analyzed in the chemical lab. Here an elemental analysis is made, to test for wear metals. The determination of the elemental content in the samples were performed using an inductively coupled plasma–optical emission spectrometry system SPECTROBLUE from Spectro Analytical Instruments GmbH, Kleve, Germany. The sample introduction system consisted of an organic torch. And a SeaSpray nebulizer. The autosampler system (Cetac ASX-520) was equipped with an organic sample needle. For the measurements a plasma power of 1490 W was used. The argon gas flow rates were as follows: cooling gas 14.0 L/min, auxiliary gas 0.6 L/min, atomizing gas 0.6 L/min and additional gas (oxygen) 0.02 L/min. For the concentration determination, standard solutions were prepared in Shellsol T with yttrium as internal standard spanning the range 10 to 100 mg/kg. Additionally, the system was calibrated before the measurements For the determination of the elemental content, 1 g of sample and another 9 g of Shellsol T with yttrium as internal standard were added to prepare the sample solution. For the calibration and the sample measurements a pump speed of 20 rpm was used. The oil samples were also characterized by measuring the physical property viscosity. These measurements were conducted using a SVM 3000 Stabinger Viscosimeter from Anton Parr at 40 °C.

Water on liner (WOL) measurements

The electrode system and diagram is depicted in Figure 3. The electrode circuit is a simple circuit consisting of a frequency generator and a resistance. The cylinder liner has been cut in halves and the electrode has been put in between, insulated by a Teflon disc on each side. The positive pole of the frequency generator has been attached to the cylinder liner, and the negative pole has been attached to the electrode. Because of the low electrical conductivity of the oil, the circuit is complete when the piston passes the electrode. It is then possible to measure the difference in the response across the introduced resistance. If water is introduced in the combustion chamber, the properties of the oil will change as it mixes with the water, as a consequence of water condensation, and this will cause a difference in the voltage measured across the resistance. For the tests conducted in this investigation, the introduced resistance was 1Ω and the frequency generator delivered a voltage of $\pm 10V$ at 100 mHz. This gives a high resolution which is important, as a signal occurs only over a very short period of time.

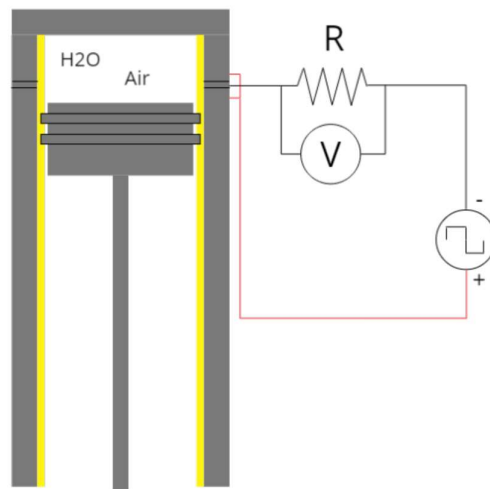

Figure 3. The electrode system and diagram.

Data interpretation

To reach a clear conclusion from the data received, it is necessary to interpret the data from the electrode and oil samples. The wear rate is estimated from the iron concentration in the oil sump, by knowing the total oil volume and the time, the wear rate can be estimated as mg iron/hour.

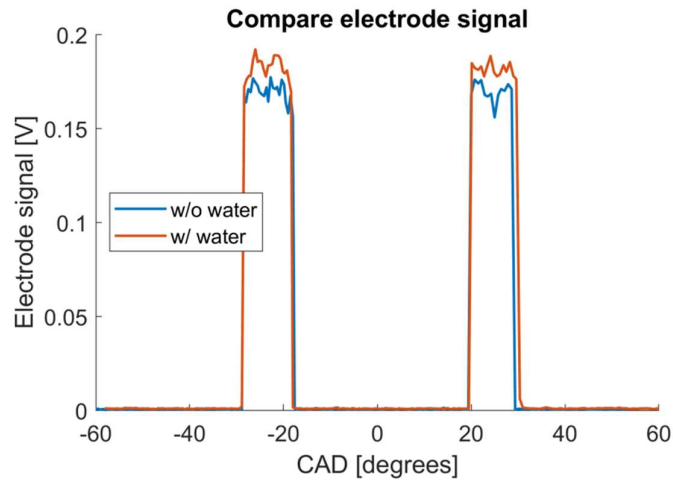

Figure 4. Signal from the electrode system.

When the piston ring passes the electrode, the oil film is compressed, and a reading can be made, in between these points, the current is very small, while there is a change in the signal in the entire cycle when water is applied, the change is greater during piston ring/electrode overlap. When water is applied, there is a clear increase in current and the voltage drop is greater during the overlap period. Figure 4 shows how the signal increases during the piston ring electrode overlap. The first signal is from the upper piston ring passing upwards, the second signal is seen when the piston ring passes downwards. With 0 CAD set as TDC. The electrode signal is interpreted at the average value of the signal during the overlap, where the overlap period is defined as any period with a signal above a threshold set at 0.05V

Results

The experiments with oil 1 were stopped after a short time since only very low wear rates and water on liner (WOL) indications were seen.

This was, however, not the case with oil 2. Figure 5 shows the accumulated Fe mass in mg Fe/kg lubricant oil as the blue line in a period of 2 weeks (20/06-04/07). The orange line shows the amount of water that was dosed into the intake charge, expressed as the water concentration in the intake charge. In order to mitigate excessive engine wear during testing, the test order is deliberately not randomized. Instead, tests with higher water content are conducted towards the end. This approach ensures that tests experiencing significant wear do not hinder the ability to perform subsequent tests.

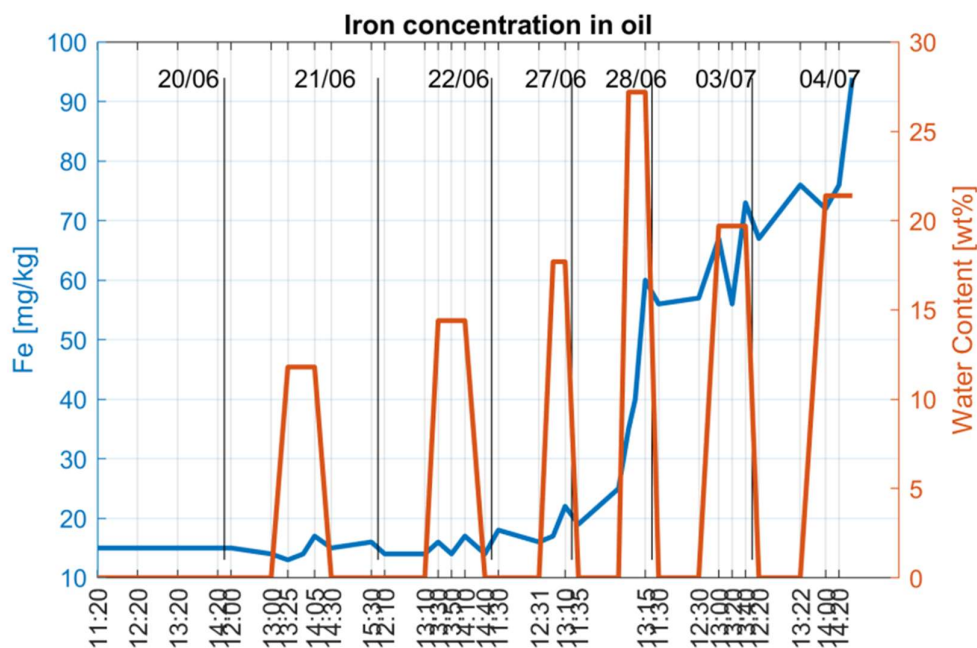

Figure 5. Accumulated Fe mass and water load in the engine intake.

The figure shows how the wear rate greatly increases as the water content in the charge gas increases. With a sudden jump around 20 wt-%. It is also clear that the wear rate is much greater using this oil, even when running dry. Figure 6 shows a similar figure from the experiments with oil 1. Here it is seen that wear rate is not associated with any significant increase when 6-10 % water is applied in the intake charge, and the wear rate is generally much lower. In Figure 7 the wear rate is plotted for both lubricants in a logarithmic scale for different water content in the charge gas, showing the difference clearly.

An obvious explanation for this could be that the synthetic lubricant contains polar base oil (probably esters), which will absorb water more likely than the non polar mineral oil. Therefore, the effect of water in the fully synthetic lubricant is much clearer.

The signals from the WOL sensor were investigated In order to see if the reason for

increased wear is due to water condensation/mixing with the lubricant. Figure 8 shows the electrode signal from the WOL sensor as a function of the wear rate for the synthetic oil, and we notice a clear connection between the two parameters. This indicates clearly that the reason for increased wear is due to water on the liner, mixing with the oil film.

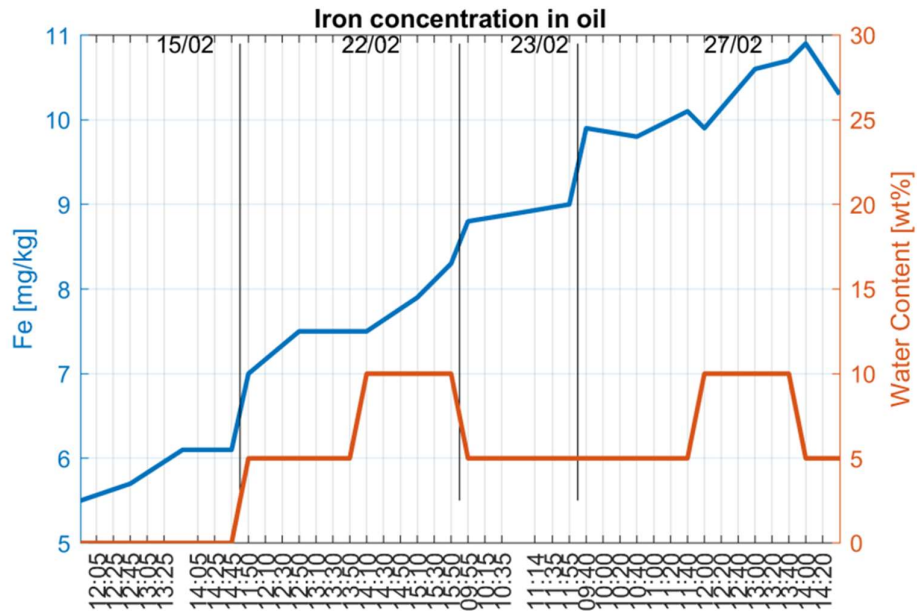

Figure 6. Accumulated Fe mass and water load in the engine intake with the application of oil 1.

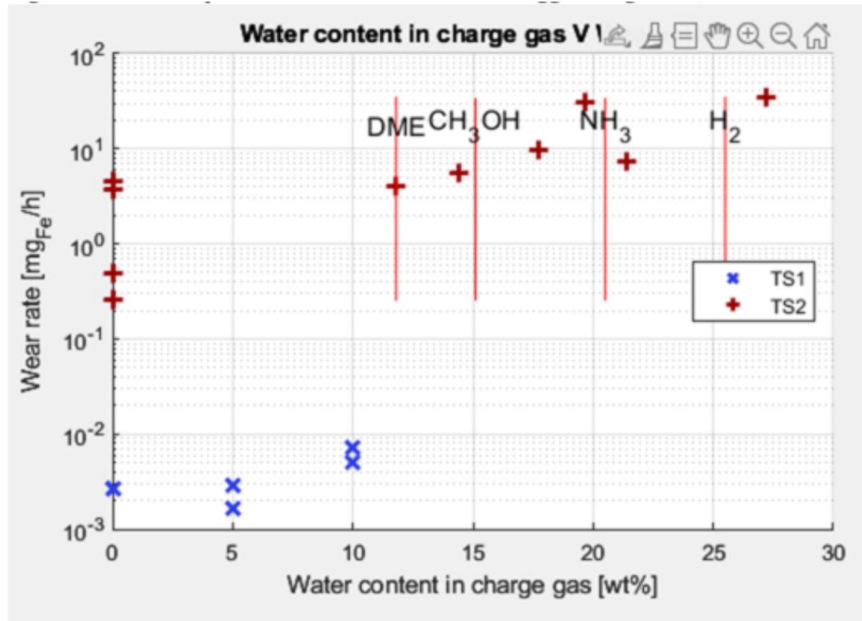

Figure 7. Wear rate versus water content in charge gas.

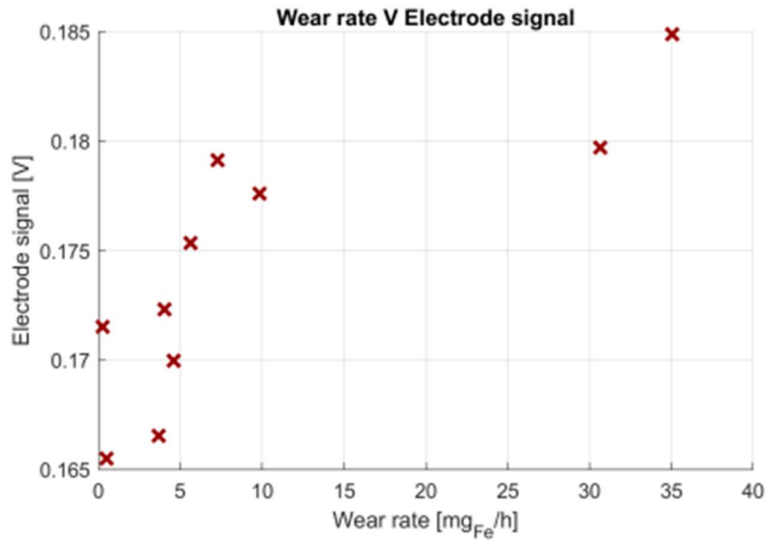

Figure 8. Electrode signal versus wear rate.

At a certain wear rate, about 10 mg_{Fe}/h the electrode signal seems to stagnate. The explanation could be that the oil cannot contain more water or the transportation speed of water through the oil film is limiting the water content of the oil film.

Conclusions

The experiments indicate that the lubricant has a strong influence on the wear damage caused by the water interaction at the cylinder liner. The less polar the lubricant is, the more protective it is against the liner corrosion caused by water condensation.

Furthermore, it is found that water concentrations in the cylinder gases around 20 % is a magic limit where the wear is speeding up dramatically. This is unfortunately in the range of exhaust water concentrations for very relevant alternative fuels as can be seen in Figure 1. Methanol exhaust contains water concentrations above 20 % for excess air ratios below 1,15 and ammonia exhaust exceeds 20 % water all the way up to an excess air ratio of 1,7. For hydrogen the situation is of course even worse. One should be aware of this issue, and precautions should of course be taken accordingly.

References

- [1] Cordtz RF, Kjemtrup L, Jensen MV, Schramm J “An experimental study of the effect of condensing water vapour on the cold corrosion wear of marine engine cylinder liners” **Lubrication Science**, vol. 34 pp 103-111, 2022.