

TNO-report  
TNO-MEP – R 99/050

TNO Institute of  
Environmental Sciences,  
Energy Research and  
Process Innovation

TNO-MEP  
Business Park E.T.V.  
Laan van Westenenk 501  
P.O. Box 342  
7300 AH Apeldoorn  
The Netherlands

Phone: +31 55 549 34 93  
Fax: +31 55 541 98 37  
Internet: www.mep.tno.nl

## Conversion of LPG distribution guidelines into DME distribution guidelines

Date  
February 1999

Author(s)  
S.J. Elbers  
M.Th. Logtenberg

Order no.  
29011

Keywords  
-- dimethyl-ether  
-- guidelines design and construction  
-- LPG installations

Intended for  
Participants project:  
Dimethyl-ether (DME) as an automotive fuel

Client/sponsors  
Participating Countries Annex XiV of IEA/AMF  
Secretariat:  
Dr. Claes Pilot                      Ing. B.J.J. van Spanje  
Roslagsvagen 54                    Novem B.V.  
S-11437 Stockholm                P.O.Box 8242  
Sweden                                NI-3503 RE Utrecht

All rights reserved.  
No part of this publication may be reproduced and/or published by print, photoprint, microfilm or any other means without the previous written consent of TNO.

In case this report was drafted on instructions, the rights and obligations of contracting parties are subject to either the Standard Conditions for Research Instructions given to TNO, or the relevant agreement concluded between the contracting parties. Submitting the report for inspection to parties who have a direct interest is permitted.

© 1999 TNO

The Quality System of the TNO Institute of Environmental Sciences, Energy Research and Process Innovation has been certified in accordance with ISO 9001.

The TNO Institute of Environmental Sciences, Energy Research and Process Innovation is a recognised contract research institute for industry and government with expertise in sustainable development and environmentally and energy oriented process innovation.



Netherlands Organization for  
Applied Scientific Research (TNO)

The Standard Conditions for Research Instructions given to TNO, as filed at the Registry of the District Court and the Chamber of Commerce in The Hague, shall apply to all instructions given to TNO.



## Preface

As a part of the international project “DME as an automotive fuel”, sponsored by IEA/AMF and Novem (NL), guidelines for DME distribution were considered. The starting point for these guidelines were the LPG distribution guidelines as in effect in the Netherlands.

The LPG guidelines consist of five specific sections i.e:

1. Regulations for the design and construction of LPG service stations
2. Regulations for the management and operation of LPG service stations
3. Regulations for the design and construction of LPG road tank trucks
4. Regulations for the management and operation of LPG road tank trucks
5. Regulations for LPG service stations and road tank trucks (appendices)

All sections have been analysed to see in how far the LPG guidelines may be applicable for DME. The main results of the analysis and the points of attention for conversion per paragraph and section are given in this report. Additional to the analysis the guidelines converted from LPG to DME are presented. It should be kept in mind that the converted guidelines are draft guidelines which are not endorsed by any authority.

## Main results of the analysis

The LPG guidelines for LPG service stations and road tank truck [1] are considered also to be applicable, for the major part, for DME. The LPG guidelines are therefore analysed in order to see where and what the differences may be. The results of this analysis are given below.

From the analysis it can be concluded that the general differences are:

- *Materials*; DME attacks most elastomers. Therefore the materials of gaskets/seals and other equipment like hoses should be DME resistant.
- *Equipment*; the properties of DME (poor viscosity and poor lubricity) complicate the design of equipment like pumps and meters, etc.
- *Calculated distances*; it should be checked whether the ‘safety’ distances as mentioned in [1] are also applicable to DME. The calculated distances for LPG can be called conservative for DME.

## Points of attention for conversion of LPG distribution guidelines into DME distribution guidelines

### Section 1: Regulations for the design and construction of LPG service stations

#### 1. Introduction

- Text should be made DME specific.

#### 2. Scope

- Text should be made DME specific.

#### 3. References

- Text is also applicable to DME.

#### 4. Definition of terms

- A definition of DME should be included.
- The definition of LPG, propane and butane can be removed.

#### 5. Definition of a LPG service station

##### 5.1 General

- The DME properties should be added into appendix I.
- Due to evaporation DME expands to  $\pm 360$  times its liquid volume (this data is only of relevance in case of a release of DME, for example due to a leakage).

## 5.2 LPG storage facilities

- The heat of combustion of propane and DME differs:  
Propane: 24.1 MJ/dm<sup>3</sup> / DME: 19.0 MJ/dm<sup>3</sup>  
This means that the energy contents of propane is 26.8 percent higher than the energy contents of DME. So if the availability of DME should be the same as propane, the storage tank of DME should be larger (26.8%) or DME should be delivered more frequently to the service stations.

## 5.3 LPG filling system

- The maximum allowable level in a DME storage tank is 86% [M.Paas].
- The warning signal should be at such a level that there is enough time to stop unloading before the 86% level is reached (set pre-alarm at 81 % ???).
- Due to the very poor conductivity of DME the system should be grounded (the same applies to LPG but is not mentioned that specific).
- Make fitting unique to avoid unloading of wrong substance.

## 5.4 LPG dispensing system

- Text is also applicable to DME.

## 5.5 Operation control and safety system

### 5.5.1 General

- Text is also applicable to DME.

### 5.5.2 Electrical control system

- Text is also applicable to DME.

### 5.5.3 Operation

- Text is also applicable to DME.

### 5.5.4 Automatic overfill protection and level control

- The maximum filling degree for DME is 86 % (see § 5.3).
- A previous warning at 81% filling degree should be given (see § 5.3).

### 5.5.5 Emergency-shutdown system

- Text is also applicable to DME.

### 5.5.6 Valve control system

- Text is also applicable to DME.
- It should be noted that no solenoids are used in a DME system (only materials that are DME resistant should be used).

## 6. Location and layout criteria

### 6.1 Location

- It should be checked whether the safety distance of 80 meter is also applicable to DME.

### 6.2 Layout

- Text is also applicable to DME.

#### 6.2.1 General

- Text is also applicable to DME.

#### 6.2.2 Minimum and maximum plot size

- There is no reason to change the requirement that all equipment is to be located within a radius of 400 meter.

#### 6.2.3 Accessibility of ancillaries

- Text is also applicable to DME.

#### 6.2.4 protection against collision

- Text is also applicable to DME.

#### 6.2.5 Installation of storage vessel(s) and pump(s)

- Text is also applicable to DME.

### 6.2.6 Installation of dispensing column

- Text is also applicable to DME.

### 6.2.7 Buried piping and cables

- Text is also applicable to DME.

## 6.3 Minimum on-plot distances

### 6.3.1 General

- Text is also applicable to DME.

### 6.3.2 Distance to low-lying places

- Text is also applicable to DME.

### 6.3.3 Distances to prevent ignition of small quantities of escaped gas

- The minimum distance of the filling point to buildings/dwelling on the site of 5 meter looks also reasonably to DME.

### 6.3.4 Distances in connection with protection of objects in case of escape and/or fire or major quantities of LPG

- It should be checked whether the minimum distance from the horizontal projection of the storage tank to a building or dwelling belonging to the establishment of 15 meter is also applicable to DME (is this distance based upon P-182 or based on heat load calculations ?).

### 6.3.5 Distances to avoid damage to coating of LPG vessels

- Text is also applicable to DME.

### 6.3.6 Location of LPG road tank trucks

- Text is also applicable to DME.

## 6.4 Minimum distances to off-plot objects

- It should be checked whether the minimum distances as mentioned in this paragraph are also applicable to DME.



## 7. Requirements

### 7.1 Design codes and regulations

- Text is also applicable to DME.

### 7.2 Vessel volume

- Text is also applicable to DME.
- See also § 5.2.

### 7.3 Design and test pressure

- Design pressure is approximately 11.5 barg.
- Test pressure =  $1.4 \times 11.5 = 16.1$  barg
- The tank has to be designed for vacuum conditions (wintertime); determine the vapour pressure of DME at  $-20^{\circ}\text{C}$ .

### 7.4 Design temperatures

- See § 7.3

### 7.5 Material

- DME is incompatible with most elastomers. Therefore the material used should be DME resistant.

### 7.6 Design

#### 7.6.1 Nozzles, manholes, vent openings

- Text is also applicable to DME.

#### 7.6.2 Connections

- The connections should be DME resistant.
- Pump pressures are in the range of 12 - 30 bar [M.Paas] so the pipelines should be resistant against a pressure of at least 30 barg.

### 7.6.3 Flanges

- The facing should be DME resistant.
- The flanges should be resistant against a pressure of at least 30 bar (see § 7.6.2).

### 7.6.4 Bolting

- It should be examined if the mentioned protection (coating) is DME resistant. In case of a leakage of DME this coating could be attacked.

### 7.6.5 Gaskets/seals

- The seals should be gastight.
- The used material should be DME resistant.

### 7.6.6 Supporting

- Text is also applicable to DME.

### 7.6.7 Lifting lugs

- Text is also applicable to DME.

### 7.6.8 Name plate

- The degree of filling for a storage vessel containing DME is 85 % (see § 5.3).

## 7.7 Welding

### 7.7.1 General

- Text is also applicable to DME.

### 7.7.2 Welding procedure qualification

- Text is also applicable to DME.

### 7.7.3 Welders performance qualification test

- Text is also applicable to DME.

#### 7.7.4 Welding processes

- Text is also applicable to DME.

#### 7.8 Weld inspection

- Text is also applicable to DME.

#### 7.9 Hydrostatic pressure testing

- The storage vessel shall be subjected to a hydrostatic pressure of 16.1 barg (see § 7.3).

#### 7.10 External coating

- In case of a leakage the external coating might be attacked. Therefore it is recommended to use a DME resistant coating.

#### 7.11 Installation of vessel

- Text is also applicable to DME.

### 8. Vessel appurtenances and LPG system ancillaries

#### 8.1 General

- A list of ancillaries for the DME system has to be made.

#### 8.2 Valves

##### 8.2.1 General

- Check whether the mechanical properties are also applicable to the use of DME.
- The material should be DME resistant (see § 5.7).

### 8.2.2 Valves on LPG storage vessels

- Text is also applicable to DME.

### 8.2.3 Remote control valve

- The design pressure of the DME storage vessel is 11.5 barg.

### 8.2.4 Excess flow valves and check valves

- It should be examined if the conditions whether or not to install a excess flow valve or check valve are the same as for DME.
- The maximum capacity of the excess flow rate in the vessel discharge should be determined for DME.

### 8.2.5 Safety valves

- The set pressure of the safety valve is  $11.5 + (0.1 \times 11.5) = 12.7$  barg.

### 8.2.6 Pressure relief valves

- From the text it is not clear how the value of 29 barg is derived. In case the set value of the pressure relief valves is the test pressure + 4 barg (for LPG: 25 + 4) than the set value for the DME system will be 20.1 barg (16.1 + 4). However, the pump pressure varies from 12 to 30 bar (see § 7.6.2). Therefore it should be checked which set value should be used.

## 8.3 Level indication and overfill protection

- The ullage valve should be placed at such a height that the maximum filling degree is 86%. (this level is based on the expansion coefficient of DME and a certain temperature difference after filling, from -20 up to +50 °C)
- It is assumed that a release of DME (colourless) will be noticed by a white cloud resulting from evaporation of DME.
- DME is a colourless gas with a slight ethereal odour.
- The overfill protection device should be activated when the level is reaching a filling degree of 86%.
- Furthermore a pre-alarm should be given in case of a filling degree of 81%.

## 8.4 Pressure and temperature indicators

- Text is also applicable to DME.

## 8.5 LPG dispensing pumps

### 8.5.1 General

- The poor viscosity and poor lubricity of DME complicates the design of dispensing pumps (the viscosity of LPG is approximately 2 times the viscosity of DME,  $\mu_{\text{DME}} = \pm 0.1 \text{ kg/m.s}$  and  $\mu_{\text{LPG}} = \pm 0.2 \text{ kg/m.s}$ )
- The design of the piping should be in accordance with the maximum pump pressure.
- The equipment belonging to the pump (seals, connections) should be DME resistant.

### 8.5.2 Submerged pumps

- It should be noticed that  $\text{CO}_2$  is highly soluble in DME and therefore  $\text{CO}_2$  should not be used for purging the system. Explosive reactions take place in the presence of oxidisers, oxygen and peroxide. Therefore an adequate inert gas should be used for purging and pressurising the system.
- The maximum capacity of the excess flow rate in the vessel discharge should be determined for DME (see also § 8.2.4).
- The seals of the pump should be gastight.
- The equipment belonging to the pump (seals, connections) should be DME resistant.
- The electrical installation of the pump should be suitable for the temperature range of  $-20^\circ$  up to  $50^\circ \text{C}$ .

## 8.6 Dispensing columns

- The hose should be DME resistant.
- Determine the maximum possible pressure in the hose.
- Determine the parameters of the excess flow valve based on a capacity of 10 kg vapour per minute.

## 8.7 Filling point assembly

- The hose connection for DME should be unique to avoid delivery of the wrong product.
- Due to the properties of DME electrical grounding is required.
- Check the maximum quantity of DME that may be blown-off as a result of an occasion and compare this amount with the maximum permissive quantity per occasion.
- A pre-alarm should be initiated at a filling degree of 81%.

- Check whether the distance to the weatherproof control cabinet is also applicable to DME.

## 9. Requirements for LPG piping

- Text is also applicable to DME.

### 9.1 Design codes and regulations

- Text is also applicable to DME.

### 9.2 Pressures

- Determine the maximum and test pressure for the DME system (see § 7.3).

### 9.3 Design temperatures

- Text is also applicable to DME.

### 9.4 Material

- The material used should be DME resistant.

#### 9.4.1 Pipe

- See also § 7.6.

#### 9.4.2 Fittings

- See also § 7.6

#### 9.4.3 Flanges

- See also § 7.6.3.

#### 9.4.4 Bolting

- See also § 7.6.4.

#### 9.4.5 Gaskets/seals

- See also § 7.6.6.

### 9.5 Design

- Select a corrosion protection which is DME resistant

### 9.6 Fabrication

#### 9.6.1 Alignment

- Cleaning should be performed in such a way that no substances will remain in the equipment after cleaning.

#### 9.6.2 Bevelling

- Text is also applicable to DME.

#### 9.6.3 Welding spacing

- Text is also applicable to DME.

### 9.7 Welding

#### 9.7.1 General

- See also § 7.7.

#### 9.7.2 Welding procedure qualification

- See also § 7.7.

#### 9.7.3 Welders performance qualification test

- See also § 7.7.

#### 9.7.4 Welder identification

- See also § 7.7.

### 9.7.5 Welder processes

- See also § 7.7.

### 9.8 Weld inspection

- See also § 7.8.

### 9.9 Pressure testing

- The test pressure for piping should be in accordance with the maximum pump pressure.

### 9.10 Testing of insulated joints

- Text is also applicable to DME.

### 9.11 Painting and coating

#### 9.11.1 External coating of buried piping

- It is advisable to use an external coating which is DME resistant.

#### 9.11.2 Painting of above ground piping

- See § 9.11.2

### 9.12 Pickling

#### 9.12.1 General instructions

- Guarantee that no substances remain in the equipment after pickling.

#### 9.12.2 Pickling with hydrochloric acid

- See § 9.12.2

#### 9.12.3 Pickling with sulphuric acid

- See § 9.12.3



## 10. Electrical requirements

### 10.1 Hazardous area classification

- Text is also applicable to DME.

### 10.2 Area zoning

- Text is also applicable to DME.

### 10.3 Electrical equipment

- Text is also applicable to DME.

### 10.4 Electrical appliances

- Text is also applicable to DME.

### 10.5 Illumination

- Text is also applicable to DME.

### 10.6 Earthing

- Check whether an earthing resistance of less than 1000 Ohm is sufficient.

### 10.7 Cathodic protection

- Text is also applicable to DME.

## 11. Special safety measures

### 11.1 Safety signs

- Text is also applicable to DME.

## 11.2 Fire-fighting equipment

- Text is also applicable to DME.

## 11.3 Supervised self-filling by customers

- Text is also applicable to DME.

## 12. Civil work requirements

### 12.1 Foundation of storage vessel

- Text is also applicable to DME.

### 12.2 Mound

- Text is also applicable to DME.

### 12.3 Underground installed vessel

- Text is also applicable to DME.

### 12.4 Drainage

- Text is also applicable to DME.

### 12.5 Fire resistance

- Text is also applicable to DME.

## 13. Inspection and approvals

### 13.1 General procedure

- Text is also applicable to DME.

## 13.2 LPG storage vessels

### 13.2.1 Design supervision

-- Text is also applicable to DME.

### 13.2.2 Fabrication supervision

-- Text is also applicable to DME.

### 13.2.3 Shop testing, vessel acceptance

-- Text is also applicable to DME.

## 13.3 Vessel appurtenances and LPG system ancillaries

-- Text is also applicable to DME.

## 13.4 LPG piping systems

-- Text is also applicable to DME.

## 13.5 Final acceptance of the LPG station facilities

-- Text is also applicable to DME.

## 14. Qualification of contractors for work on LPG installations

-- Text is also applicable to DME.

## Section 2: Regulations for the management and operation of LPG service stations

### 1. Introduction

- Text has to be changed.

### 2. Scope

- Text has to be changed.

### 3. Definition of terms

- Add the definition of DME.
- Delete the definitions of butane, propane and LPG

### 4. Product information

#### 4.1 Propane, butane and LPG

- DME is produced from ‘syngas’(mixture of H<sub>2</sub>, CO and CO<sub>2</sub>)  
Natural Gas → (steam, reformer) → ‘syngas’ → methanol syntheses → DME  
coal, oil residues, biomass → gassification → ‘syngas’ → methanol syntheses  
→ DME

#### 4.2 Properties of LPG

- boiling point: -24.8 °C;
- vapour pressure (20°C): 5.1 bar;
- expansion to 360 times its original liquid volume;
- gaseous DME is 1.83 times heavier than air;
- It should be checked whether a release of DME becomes a visible cloud.
- DME has a slight ethereal odour;
- DME is not corrosive;
- DME attacks most elastomers;
- DME is a poor conductor;

- DME has a poor fuel viscosity;
- DME has a poor lubricity.

## **5. Management of the installation**

### **5.1 Operating staff**

- Text is also applicable to DME.

### **5.2 Installation book**

- Text is also applicable to DME.

### **5.3 Emergency plan**

- Text is also applicable to DME.

### **5.4 Medical first aid**

- Text is also applicable to DME.

### **5.5 ADR product card**

- Text is also applicable to DME.

### **5.6 Fire fighting equipment**

- Text is also applicable to DME.

### **5.7 Storage vessel area**

- Text is also applicable to DME.

### **5.8 Damage by plantation**

- Text is also applicable to DME.

### 5.9 Position of remote-controlled valves

- Text is also applicable to DME.

### 5.10 Degassing and ingassing of storage vessel

- Do not use CO<sub>2</sub> for degassing.

### 5.11 Installation /dismounting of submerged pumps

- Text is also applicable to DME.

### 5.12 Safe handling of LPG

- CO<sub>2</sub> should not be used for degassing.
- Exposure to skin or eyes can also cause irritation or dermatitis. If exposure is to the eyes it causes inflammation of the ocular mucous membranes. In addition contact with the vaporising liquid can cause frost bite.

### 5.13 Reporting of incidents

- Text is also applicable to DME.

## 6. LPG deliveries to customers

### 6.1 Restrictions concerning the deliveries

- Text is also applicable to DME.

### 6.2 Safety measures

- Text is also applicable to DME.

### 6.3 Supervised self-filling by customers

- Text is also applicable to DME.

## 6.4 Illumination

- Text is also applicable to DME.

## 7. LPG storage vessel filling

### 7.1 Road tank truck

- Text is also applicable to DME.

### 7.2 Driver of the truck

- Text is also applicable to DME.

### 7.3 Truck engine

- Text is also applicable to DME.

### 7.4 Artificial lighting

- Text is also applicable to DME.

### 7.5 Connection of station's and truck's control systems

- Text is also applicable to DME.

### 7.6 Filling hoses

- Text is also applicable to DME.

### 7.7 Filling procedure

- Text is also applicable to DME.

## 8. Maintenance, repairs and inspections

### 8.1 General

- Text is also applicable to DME.

### 8.2 Maintenance and repairs

- Text is also applicable to DME.

### 8.3 Modifications

- Text is also applicable to DME.

### 8.4 Work permit

- Check which amount of vapour should be involved in de-pressurising the installation before the measures concerned must be laid down in writing (work permit).

### 8.5 Periodic inspections

- Text is also applicable to DME.



## **Section 3: Regulations for the design and construction of LPG road tank trucks**

### **1. Introduction**

- Text has to be changed.

### **2. Scope**

- Text has to be changed.

### **3. References**

- Text is also applicable to DME.

### **4. Definition of terms**

- The definition of DME should be added.
- The definition of butane, propane and LPG can be removed.

### **5. Description of a LPG road tank truck**

#### **5.1 General**

- Text is also applicable to DME.

#### **5.2 The vessel**

- Text is also applicable to DME.

#### **5.3 Unloading and filling system**

- Text is also applicable to DME.

#### 5.4 Operation control

- Text is also applicable to DME.

#### 5.5 Additional safety measures

- Text is also applicable to DME.

### 6. General design requirements

#### 6.1 Governing regulations

- A list of requirements with regard to DME should be derived from the ADR.

#### 6.2 Design fluid

- The following information should be derived from ADR:  
Class;  
Item no.

#### 6.3 Carrying vehicle

- Text is also applicable to DME.

#### 6.4 Mounting of vessel and piping on chassis

- Text is also applicable to DME.

#### 6.5 Fire fighting appliances

- Text is also applicable to DME.

#### 6.6 Labelling and marking

- Text is also applicable to DME.

## 7. Safety systems

### 7.1 Emergency shutdown systems

- Text is also applicable to DME.

### 7.2 Thermal pneumatic plastic tube

- Text is also applicable to DME.

### 7.3 Bonding

- Text is also applicable to DME.

### 7.4 Drive-off alarm

- Text is also applicable to DME.

## 8. Requirements for LPG vessels

### 8.1 Design codes and regulations

- Text is also applicable to DME.

### 8.2 Vessel volume

- Text is also applicable to DME.

### 8.3 Degree of filling

- The maximum filling degree of 86 % should be taken into account [M.Paas].

### 8.4 Design pressure

- The design pressure for vessels provided with sunshield is 16 barg
- The design pressure for vessels without provisions is 18 barg.

## 8.5 Hydraulic test pressure

- The hydraulic test pressure for vessels provided with sunshield is 16 barg
- The hydraulic test pressure for vessels without provisions is 18 barg.

## 8.6 Design temperatures

- Text is also applicable to DME.

## 8.7 Material

- Check the requirements with regard to DME in ADR

## 8.8 Vessel connections

### 8.8.1 General

- Text is also applicable to DME.

### 8.8.2 Required connections

- Check whether the minimum restrictions as mentioned here are also applicable to DME.

### 8.8.3 Location

- Check whether the location of connections having a bore of more than 2 mm<sup>2</sup> is also applicable to DME.

### 8.8.4 Size

- Check whether the requirements with regard to the strength are also applicable to DME.

## 9. Vessel appurtenances and LPG system ancillaries

### 9.1 General

- Text is also applicable to DME.

### 9.2 Valves

#### 9.2.1 General

- Check whether the mechanical properties are also applicable to the use of DME.
- The material should be DME resistant (see also section 1, § 8.2.1).

#### 9.2.2 Bottom valves

- The differential pressure in case of DME is 16 barg respectively 18 barg.

#### 9.2.3 Excess flow valves and check valves

- Check whether the conditions for installing an excess flow valve or a check valve are also applicable to DME.

#### 9.2.4 Hand operated block valves

- Text is also applicable to DME

#### 9.2.5 Safety valves

- The set pressure for safety valves in case of national transport is 12.7 barg.

#### 9.2.6 Pressure relief valves

- The set pressure for the safety relief valve is 20 barg (see section 1: §8.2.1).
- The set pressure should be higher than the operating pressure (see section 1: § 7.6.2).

#### 9.2.7 Blow-off valves

- Check the maximum quantity of DME that may be blown-off as a result of a certain occasion and compare this amount with the maximum permissive quantity per occasion.

### 9.3 Liquid level indication and filling grade control

#### 9.3.1 Ullage valve assembly

- Check the maximum opening for a fixed internal pipe for DME.
- The maximum liquid level is 81%.

#### 9.3.2 Level indicator

- Text is also applicable to DME

#### 9.3.3 Overfill alarm

- The setting of the alarm will be at a filling degree of 81%.

### 9.4 Pressure and temperature indicators

- Text is also applicable to DME

### 9.5 Filters

- The material used should be DME resistant.

### 9.6 Transfer pumps

- The poor viscosity and poor lubricity of DME complicates the design of dispensing pumps.
- The design of the piping should be in accordance with the maximum pump pressure.
- The equipment belonging to the pump (seals, connections) should be DME resistant.

### 9.7 Flow meters

- The design pressure should be at least 30 barg (see section 1: § 7.6.2).
- the flowmeters should be DME resistant.

### 9.8 Flexible joint

- Text is also applicable to DME

## 9.9 Hoses and hose reels

### 9.9.1 Hose reel assemblies

- The design pressure should be at least 30 barg (see section 1: § 7.6.2).
- Assemblies should be DME resistant.

### 9.9.2 Hoses

- Check which burst pressure should be met for hoses
- Hoses should be DME resistant.

### 9.9.3 Hose couplings and adapters

- The equipment should be suitable for DME.

## 10. Requirements for LPG piping

### 10.1 Design codes and regulations

- Text is also applicable to DME.

### 10.2 Design and test pressures

- The test pressure should be at least 30 barg (see section 1: § 7.6.2).

### 10.3 Design temperatures

- Text is also applicable to DME

### 10.4 Design

- Text is also applicable to DME

### 10.5 Material

- The materials should be DME resistant.

### 10.5.1 Pipe

- Check whether the maximum specified strength is also applicable to DME.

### 10.5.2 Fittings

- Text is also applicable to DME

### 10.5.3 Flanges

- Text is also applicable to DME

### 10.5.4 Bolting and threaded connections

- Text is also applicable to DME

### 10.5.5 Gaskets/seals

- Text is also applicable to DME

## 10.6 Fabrication

- Text is also applicable to DME.

## 10.7 Welding

### 10.7.1 General

- Text is also applicable to DME

### 10.7.2 Welding procedure qualification

- Text is also applicable to DME.

### 10.7.3 Welders performance qualification test

- Text is also applicable to DME.

### 10.7.4 Welder identification

- Text is also applicable to DME.



### 10.7.5 Welding processes

- Text is also applicable to DME.

### 10.7.6 Weld inspection

- Text is also applicable to DME.

## 10.8 Pressure testing

### 10.8.1 Hydrostatic pressure test

- The hydrostatic pressure test should be at least 30 bar because of the fact that the pump pressure is in the range of 12 - 30 bar.

### 10.8.2 Pneumatic tightness test

- Text is also applicable to DME.

### 10.8.3 Test records

- Text is also applicable to DME.

## 11. Electrical requirements

### 11.1 Hazardous area classification

- Text is also applicable to DME.

### 11.2 Area zoning

- Text is also applicable to DME.

### 11.3 Electrical equipment

- Text is also applicable to DME.

#### 11.4 Electrical appliances

- Text is also applicable to DME.

#### 11.5 Earthing

- DME is a poor conductor and therefore grounding is required.

### 12. Inspection and approvals

#### 12.1 First inspection

##### 12.1.1 LPG vessels

- Text is also applicable to DME.

##### 12.1.2 Vessel appurtenances and LPG system ancillaries

- Text is also applicable to DME.

##### 12.1.3 LPG piping systems

- Text is also applicable to DME.

#### 12.2 Final acceptance of the LPG station facilities

- Text is also applicable to DME.

### 13. Qualification of contractors for work on LPG installations

- Text is also applicable to DME.

## Section 4: Regulations for the management and operation of LPG service stations

### 1. Introduction

- Text has to be changed.

### 2. Scope

- Text has to be changed.

### 3. Definition of terms

- Add the definition of DME.
- Remove the definition of LPG and propane.

### 4. Product information

#### 4.1 Propane, butane and LPG

- DME is produced from 'syngas'(mixture of H<sub>2</sub>, CO and CO<sub>2</sub>)  
Natural Gas → (steam, reformer) → 'syngas' → methanol syntheses → DME  
coal, oil residues, biomass → gassification → 'syngas' → methanol syntheses  
→ DME

#### 4.2 Properties of LPG

- boiling point: -24.8 °C;
- vapour pressure (20°C): 5.1 bar;
- expansion to 360 times its original liquid volume;
- gaseous DME is 1.83 times heavier than air;
- It should be checked whether a release of DME becomes a visible cloud.
- DME has a slight ethereal odour;
- DME is not corrosive;
- DME attacks most elastomers;
- DME is a poor conductor;

- DME has a poor fuel viscosity;
- DME has a poor lubricity.

## 5. Description of a LPG road tank truck

- Text is also applicable to DME.

## 6. Driver certificate and training

### 6.1 Driver certificate

- Text is also applicable to DME.

### 6.2 Instructions for driver training

- Text is also applicable to DME.

## 7. General instructions for drivers

### 7.1 Driver's clothing

- Text is also applicable to DME.

### 7.2 Daily checklist for drivers

- Text is also applicable to DME.

### 7.3 Prohibitions

- Text is also applicable to DME.

## 8. Loading, transport and discharge of LPG

### 8.1 Driver duties and responsibilities

- Text is also applicable to DME.

### 8.2 Loading of the tank truck

- Text is also applicable to DME.

### 8.3 Transport of LPG

- Check whether the distances at which reflecting triangles should be placed in case of a vehicle immobilisation are also applicable to DME.

### 8.4 Discharge of LPG

- Text is also applicable to DME.

## 9. Emergency procedures

### 9.1 LPG leakage at the supply station

- Text is also applicable to DME.

### 9.2 LPG leakage at the service station

- Text is also applicable to DME.

### 9.3 LPG leak during transport

- Text is also applicable to DME.

## 10. Fire fighting instructions

### 10.1 General

- Text is also applicable to DME.

### 10.2 Small fires

- Text is also applicable to DME.

### 10.3 Large fires

- Text is also applicable to DME.

### 10.4 Reporting fires

- Text is also applicable to DME.

## 11. Maintenance, repairs and modifications

### 11.1 Maintenance and repair

- Text is also applicable to DME.

### 11.2 Modifications

- Text is also applicable to DME.

### 11.3 Work permit

- Check which amount of DME should be involved in depressing/ degassing of the installation before the measures concerned must be laid down in writing and signed by.

## 12. Periodic inspections

- Text is also applicable to DME.

### 12.1 Inspections by truck driver

- Text is also applicable to DME.

### 12.2 Inspections by qualified contractor

- The setting of hydraulic pressure test for DME is 20.1 barg (see section 1: § 8.2.1).
- The set pressure for the hydraulic pressure test should be in accordance with the maximum operating pressure.

### 12.3 Inspection by the inspection agency

#### 12.3.1 3 years inspection period

- Text is also applicable to DME.

#### 12.3.2 6 years inspection period

- Text is also applicable to DME.

#### 12.3.3 Inspections during modifications

- Text is also applicable to DME.

### 12.4 Vehicle inspection

- Text is also applicable to DME.

## 13. Installation book

- Text is also applicable to DME.

## Appendices

### Appendix 1 Product information

- This appendix should be made specific for DME.

### Appendix 2 Appurtenances for propane and butane, list of accepted makes

- This appendix should be made specific for DME.

### Appendix 3 Regulations concerning the qualification of contractors for the construction, maintenance, repair, inspection and testing of LPG-installations

- Text is also applicable to DME.

### Appendix 4 Procedure for the commissioning of new or degassed LPG-installations

- Determine the pressures which should be used for the leak test of the DME system.
- The leak test should be performed by using DME or nitrogen (or another inert gas: CO<sub>2</sub>, oxygen and air are prohibited).

### Appendix 5 Procedure for de-pressurising and degassing the LPG-installation

- The equipment should be purged with nitrogen or another inert gas (CO<sub>2</sub>, oxygen and air are prohibited).

### Appendix 6 Procedure for the installation/dismounting of submerged pumps

- Text is also applicable to DME.



### **Appendix 7    ADR-product card (transport emergency group card)**

- Text is also applicable to DME.

### **Appendix 8    Medical first aid**

- Text is also applicable to DME.

### **Appendix 9    Example of emergency plan**

- Text is also applicable to DME.

### **Appendix 10    Installation book for LPG service stations**

- Text is also applicable to DME.

### **Appendix 11    Installation book for LPG tank truck drivers and truck owners**

- Text is also applicable to DME.

### **Appendix 12    Applicable articles of the ADR concerning LPG road tank trucks**

- The relevant articles of the ADR concerning DME should be collected.

### **Appendix 13    Checklists for inspection of LPG service stations**

- Text is also applicable to DME.

## Authentication

Name and address of the principal:

TNO Road-Vehicles Research Institute  
Schoemakerstraat 97  
P.O. Box 6033  
2600 JA Delft  
The Netherlands

Names and functions of the cooperators:

S.J. Elbers  
M.Th. Logtenberg

Names and establishments to which part of the research was put out to contract:

-

Date upon which, or period in which, the research took place:

June 1998 - February 1999

Signature:

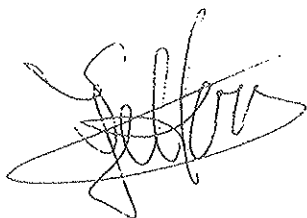

S.J. Elbers (B.Sc.)  
risk analyst

Approved by:



J.S. Schaafsma (M.Sc.)  
head of department

**Converted Distribution Guidelines**  
(from LPG to DME)



TNO-report  
TNO-MEP – R 99/29011

## Regulations for DME Service Stations and Road Tank Trucks in the Netherlands

TNO Institute of  
Environmental Sciences,  
Energy Research and  
Process Innovation

### Section 1: Regulations for the design and construction of DME service stations

Laan van Westenenk 501  
P.O. Box 342  
7300 AH Apeldoorn  
The Netherlands

Date  
10-02-99

Phone +31 55 - 549 34 93  
Fax +31 55 - 541 98 37

Author(s)  
S.J. Elbers

Order no.

This draft report is supplied for internal use only and the results may not be made known to third parties as having been produced by TNO.

In this respect attention is drawn to article 8 (liability) and article 4 (rights concerning results) of the Standard Conditions for Research instructions given to TNO.

Keywords

Intended for

All rights reserved.

No part of this publication may be reproduced and/or published by print, photoprint, microfilm or any other means without the previous written consent of TNO.

In case this report was drafted on instructions, the rights and obligations of contracting parties are subject to either the Standard Conditions for Research Instructions given to TNO, or the relevant agreement concluded between the contracting parties. Submitting the report for inspection to parties who have a direct interest is permitted.

© 1998 TNO

The Quality System of the TNO Institute of Environmental Sciences, Energy Research and Process Innovation has been certified in accordance with ISO 9001.

The TNO Institute of Environmental Sciences, Energy Research and Process Innovation is a recognised contract research institute for industry and government with expertise in sustainable development and environmentally oriented process innovation.

Netherlands Organisation for  
Applied Scientific Research (TNO)

The Standard Conditions for Research Instructions given to TNO, as filed at the Registry of the District Court and the Chamber of Commerce in The Hague, shall apply to all instructions given to TNO.

## General introduction

The 'Regulations for DME Service Stations and Road Tank Trucks in the Netherlands' as provided herewith have been prepared on behalf of *[HOLD]*.

The contents of this report is based on the governing Dutch regulations for LPG installations - i.e. LPG Service Stations and Road Tank Trucks [1] - and made where necessary specific for DME. The report is meant to provide those concerned abroad with detailed information and guidance for the safe distribution of DME.

These 'Regulations' comprise four sections and thirteen appendices as listed on the next page. The subjects covered in the four sections are interrelated and therefore their contents should be considered as a total package.

## Overall Table of Contents

### Sections

- |   |                                                                        |
|---|------------------------------------------------------------------------|
| 1 | Regulations for the design and construction of DME service stations    |
| 2 | Regulations for the Management and Operation of DME Service stations   |
| 3 | Regulations for the design and construction of DME Road Tanker Trucks  |
| 4 | Regulations for the Management and Operation of DME Road Tanker Trucks |

### Appendices

- |      |                                                                                                                                                |
|------|------------------------------------------------------------------------------------------------------------------------------------------------|
| I    | Product information                                                                                                                            |
| II   | Appurtenances for propane and butane, list of accepted makes                                                                                   |
| III  | Regulations concerning the qualification of contractors for the construction, maintenance, repair, inspection and testing of DME-installations |
| IV   | Procedure for the commissioning of new or degassed DME-installations                                                                           |
| V    | Procedure for de-pressurising and degassing the DME-installation                                                                               |
| VI   | Procedure for the installation/dismounting of submerged pumps                                                                                  |
| VII  | ADR-product card (transport emergency group card)                                                                                              |
| VIII | Medical first aid                                                                                                                              |
| IX   | Example of emergency plan                                                                                                                      |
| X    | Installation book for DME service stations                                                                                                     |
| XI   | Installation book for DME tank truck drivers and truck owners                                                                                  |
| XII  | Applicable articles of the ADR concerning DME road tank trucks                                                                                 |
| XIII | Checklists for inspection of DME service stations                                                                                              |

## Section 1: Regulations for the design and construction of DME service stations

### Table of contents

1. INTRODUCTION .....	8
2. SCOPE.....	9
3. REFERENCES OF STANDARDS.....	10
3.1 MECHANICAL STANDARDS.....	10
3.2 ELECTRICAL STANDARDS.....	13
3.3 SAFETY STANDARDS.....	13
4. DEFINITION OF TERMS .....	15
5. DEFINITION OF A DME SERVICE STATION.....	19
5.1 GENERAL.....	19
5.2 DME STORAGE FACILITIES.....	19
5.3 DME FILLING SYSTEM .....	20
5.4 DME DISPENSING SYSTEM .....	21
5.5 OPERATION CONTROL AND SAFETY SYSTEMS.....	22
5.5.1 General.....	22
5.5.2 Electrical control system .....	22
5.5.3 Operation.....	23
5.5.4 Automatic overfill protection/level control.....	24
5.5.5 Emergency shut-down system (ESD) .....	24
5.5.6 Valve control systems .....	25
6. LOCATION AND LAYOUT CRITERIA.....	32
6.1 LOCATION.....	32
6.2 LAY-OUT.....	32
6.2.1 General.....	32
6.2.2 Minimum and maximum plot size .....	33
6.2.3 Accessibility of ancillaries.....	33
6.2.4 Protection against collision.....	33
6.2.5 Installation of storage vessel(s) and pump(s).....	33
6.2.6 Installation of dispensing-column(s) .....	34
6.2.7 Buried piping and cables.....	34
6.3 MINIMUM ON-PLOT DISTANCES .....	34
6.3.1 General.....	34
6.3.2 Distance towards low-lying places.....	35
6.3.3 Distances to prevent ignition of small quantities of escaped gas .....	35
6.3.4 Distances in connection with protection of objects in case of-escape and/or fire of major quantities of DME.....	35
6.3.5 Distances to avoid damage to coating of DME vessels .....	36
6.3.6 Location of DME road tank trucks .....	36
6.4 MINIMUM DISTANCES TO OFF-PLOT OBJECTS.....	36



7. REQUIREMENTS .....	41
7.1 DESIGN CODES AND REGULATIONS .....	41
7.2 VESSEL VOLUME .....	41
7.3 DESIGN AND TEST PRESSURES .....	41
7.4 DESIGN TEMPERATURES .....	42
7.5 MATERIAL .....	42
7.6 DESIGN .....	42
7.6.1 Nozzles, manholes, vent openings .....	42
7.6.2 Connections .....	43
7.6.3 Flanges .....	43
7.6.4 Bolting .....	43
7.6.5 Gaskets/Seals .....	44
7.6.6 Supporting .....	44
7.6.7 Lifting ludge .....	44
7.6.8 Name plate .....	44
7.7 WELDING .....	45
7.7.1 General .....	45
7.7.2 Welding procedure qualification .....	45
7.7.3 Welders performance qualification test .....	45
7.7.4 Welding processes .....	45
7.8 WELD INSPECTION .....	46
7.9 HYDROSTATIC PRESSURE TESTING .....	46
7.10 EXTERNAL COATING .....	46
7.11 INSTALLATION OF VESSEL .....	47
8. VESSEL APPURTENANCES AND DME SYSTEM ANCILLARIES .....	49
8.1 GENERAL .....	49
8.2 VALVES .....	49
8.2.1 General .....	49
8.2.2 Valves on DME storage vessels .....	49
8.2.3 Remote controlled valves .....	49
8.2.4 Excess flow valves and check valves .....	50
8.2.5 Safety valves .....	50
8.2.6 Pressure relief valves .....	51
8.3 LEVEL INDICATION AND OVERFILL PROTECTION .....	51
8.4 PRESSURE AND TEMPERATURE INDICATORS .....	52
8.5 DME DISPENSING PUMPS .....	53
8.5.1 General .....	53
8.5.2 Submerged pumps .....	53
8.6 DISPENSING COLUMNS .....	56
8.7 FILLING POINT ASSEMBLY .....	57
9. REQUIREMENTS FOR DME PIPING .....	59
9.1 DESIGN CODE/REGULATIONS .....	59
9.2 PRESSURES .....	59
9.3 DESIGN TEMPERATURE .....	59
9.4 MATERIAL .....	59
9.4.1 Pipe .....	59
9.4.2 Fittings .....	60

9.4.3 Flanges .....	60
9.4.4 Bolting .....	60
9.4.5 Gaskets and seals .....	60
9.5 DESIGN .....	60
9.6 FABRICATION .....	61
9.6.1 Alignment .....	61
9.6.2 Beveling .....	62
9.6.3 Welding spacing .....	62
9.7 WELDING .....	62
9.7.1 General .....	62
9.7.2 Welding procedure qualification .....	62
9.7.3 Welders performance qualification test .....	62
9.7.4 Welder identification .....	63
9.7.5 Welding processes .....	63
9.8 WELD INSPECTION .....	63
9.9 PRESSURE TESTING .....	63
9.10 TESTING OF THE INSULATION JOINTS .....	64
9.11 PAINTING AND COATING .....	64
9.11.1 External coating of buried piping .....	64
9.11.2 Painting of above ground piping .....	64
9.12 PICKLING .....	65
9.12.1 General instructions .....	65
9.12.2 Pickling with hydrochloric acid (HCl) without passivating .....	65
9.12.3 Pickling with sulphuric acid (H <sub>2</sub> SO <sub>4</sub> ) without passivating .....	66
10. ELECTRICAL REQUIREMENTS .....	67
10.1 HAZARDOUS AREA CLASSIFICATION .....	67
10.2 AREA ZONING .....	67
10.3 ELECTRICAL EQUIPMENT .....	68
10.4 ELECTRICAL APPLIANCES .....	68
10.5 ILLUMINATION .....	68
10.6 EARTHING .....	69
10.7 CATHODIC PROTECTION .....	69
11. SPECIAL SAFETY MEASURES .....	72
11.1 SAFETY SIGNS .....	72
11.2 FIRE-FIGHTING EQUIPMENT .....	72
11.3 SUPERVISED SELF-FILLING BY CUSTOMERS .....	72
12. CIVIL WORK REQUIREMENTS .....	73
12.1 FOUNDATION OF STORAGE VESSEL .....	73
12.2 MOUND .....	73
12.3 UNDERGROUND INSTALLED VESSEL .....	74
12.4 DRAINAGE .....	74
12.5 FIRE-RESISTANCE .....	74
13. INSPECTION AND APPROVALS .....	76
13.1 GENERAL PROCEDURE .....	76
13.2 DMĒ STORAGE VESSELS .....	76
13.2.1 Design supervision .....	76

13.2.2 Fabrication supervision.....76  
13.2.3 Shop testing/vessel acceptance.....77  
13.3 VESSEL APPURTENANCES AND DME SYSTEM ANCILLARIES.....77  
13.4 DME PIPING SYSTEMS.....77  
13.5 FINAL ACCEPTANCE OF THE DME STATION FACILITIES .....77  
14. QUALIFICATION OF CONTRACTORS FOR WORK ON DME  
INSTALLATIONS .....79  
15. LIST OF LITERATURE .....80

**Applicable appendices**

Appendix I DME product information  
Appendix II Appurtenances for DME  
List of accepted makes  
Appendix III Regulations concerning the qualification of contractors for he  
construction, maintenance, repair inspection, and testing of DME-  
installations.  
Appendix XIII Checklist for inspection of DME service stations

## 1. Introduction

This section forms part of the 'Regulations for DME Service Stations and Road Tank Trucks'.

It provides the regulations for the design and construction of DME service stations with DME storage of the 'mounded' type, i.e. storage vessels installed above grade covered with a mound of sand, as well as DME storage installed above ground.

In recent years studies have been performed for the introduction of DME as a car fuel. Part of these studies are related to the evaluation of the risk when handling DME. As a result of these studies a number of measures have been and are still being taken to improve the safety of DME handling in all its aspects.

The 'Regulations for the design and Construction of DME service stations' given in this section are based on the existing requirements for LPG service stations [1] and made specific for DME where necessary.

The application of the 'Regulations' as mentioned in this section will contribute to the safe construction of DME stations and to the prevention of hazards while handling this product. It should be noticed however that the design criteria as stated in this section are based on the climatological conditions of the Netherlands; and thus are not automatically applicable to other countries which might have other climatological conditions.

While every effort has been made to ensure the accuracy and reliability of the data contained in these regulations, neither TNO nor the authors shall be held responsible or liable in any way for loss or damage resulting from their use or from any violation of state or international regulations with which they may conflict.

The regulations also cannot be deemed to contain all conditions that must be necessarily be fulfilled for safe construction and usage. The liability remains with principals, manufacturers and the management for the installation.

## 2. Scope

This section covers the requirements related to the design and construction of DME service stations, comprising facilities for the supply with DME, DME product storage and the delivery of DME to motorcars.

The section provides guidance for a safe location and lay-out of a DME service station in its entirety and forms a basis of design for its facilities and systems. All mandatory design criteria such as minimum safety distances, area classifications, storage capacities etc. are given in addition to detailed requirements for the design, installation, inspection and testing of individual equipment of the complete system.

In this section reference is made to Appendices I, II, III and XIII of the 'Regulations' which contain information regarding DME properties, accepted makes of DME appurtenances, regulations for the qualification as a DME contractor and checklists for inspection of DME service stations.

The operational aspects of DME service stations are covered in section 2, 'Regulations for the management and operation of DME service stations', which also forms part of the 'Regulations for DME Service Stations and Road Tank Trucks'.

### 3. References of standards

In these Regulations reference is made to the following publications:

Note: The latest issue of each publication should be used together with any amendments/supplements/ revisions to such publications.

#### 3.1 Mechanical Standards

##### ASME Boiler and Pressure Vessel Code:

Section VIII, div. 1	Pressure Vessels
Section IX	Welding and brazing qualifications

##### ASME Code for Pressure Piping B 31:

ANSI/ASME B 31.3	Chemical plant and petroleum refinery piping
------------------	----------------------------------------------

Published by:	The American Society of Mechanical Engineers. 345 East 47th street New York, New York 10017.
---------------	----------------------------------------------------------------------------------------------------

##### ASTM Codes:

ASTM A 105	Specification for forgings, carbon steel, for piping components
ASTM A 106	Specification for seamless carbon steel pipe for high temperature service
ASTM A 234	Specification for Piping Fittings of wrought carbon steel and alloy steel
ASTM A 285	Specification for Pressure vessel Plates, carbon steel, low- and intermediate - tensile strength
ASTM A 515	Specification for Pressure Vessel Plates, carbon steel, for intermediate - and higher temperature service
ASTM A 520	Specification for supplementary requirements for seamless and electric resistance welded carbon steel tubular goods

Published by:	American Society for Testing and Materials 1916 Race street Philadelphia, PA 19103
---------------	------------------------------------------------------------------------------------------

BS Codes:

BS 1640	Steel butt-welding fittings for the petroleum industry
BS 3600	Specification for dimensions and masses per unit length of welded and seamless steel pipes and tubes for pressure purposes
BS 3799	Steel pipe fittings, screwed and socket welding for the petroleum industry
BS 4504	Flanges and Bolting for pipes, valves and fittings. Metric series
BS 4870	Specification for approval testing of welding procedures
BS 4871	Specification for approval testing of welders working to approved welding procedures
BS 5146	Steel valves for the petroleum petro-chemical and allied industries (appendix A)
BS 5500	Specification for unfired fusion welded pressure vessels.

Published by: British Standards Institution  
2 Park Street  
London W 1 A 2 BS

CEOC Codes:

R49/CEOC/83	Approval of manufacturers of fittings and flanges
R25/CEOC/79	Principles for the approval of austenitic rolled and forged steels
R26/CEOC/79	Principles for approving materials for components which require inspection by a CROC-Organisation
R29/CEOC/83	Test plan for the certification of rolled and forged steels including fine-grain structural steels with ferritic-pearlitic structure (normalised) , bainitic structure and/or tempered structure (air or liquid quenched as well as age hardened)

Published by: CEOC (Colloque Européen des Organismes de Contrôle):  
Secrétariat Général  
Groupements des APAVE  
102, Rue des Poissonniers  
75018 Paris

DIN CODES:

DIN 1629 sht 3	Seamless pipe from carbon steel
DIN 2448	Plain and seamless steel pipe
DIN 2513	Flanges, facings, male and female
DIN 2526	Flanges, types of facings
DIN 2605	Butt-welded elbows
DIN 2615	Steel butt-welded fittings, tees
DIN 2616	Steel butt-welded fittings, reducers
DIN 2617	Steel butt-welded fittings, caps
DIN 2634	Welded neck flanges, NP 25

DIN 2635	Welded neck flanges, NP 40
DIN 2980	Threaded steel pipe fittings
DIN 3754	Compressed asbestos fibre sheets
DIN 17155	Plate for pressure vessels
DIN 17200	Quenched and tempered steels
DIN 30670)	
DIN 30671)	
DIN 30672)	Anti corrosion coating
DIN 30673)	
DIN 30675)	

Published by: Deutsches Institut für Normung  
Beuth verlag G.m.b.E.  
Burggrafenstrasse 4-10  
1000 Berlin 30

IIS/IM codes:

IIS/IIW-237-66	Recommended welded connections for pressure vessels
IIS/IIW-487-75	Suitability grading
IIS/IIW-492-75	Recommended practice for radiographic inspection of fusion welded circumferential joints in steel pipes from 1 mm up to 50 mm wall thickness class B

Published by: International Institute of Welding  
54 Princess Gate, Exhibition Road London  
S.M.

ISO Specifications:

ISO 6708	Pipe components. Definition of nominal size
ISO 7268	Pipe components. Definition of nominal pressure

Published by: International Standardisation organisation Geneva,  
Switzerland

Dutch Standard Specifications:

NPR 6912	Cathodic protection
----------	---------------------

Published by: Nederlandse Normalisatie Instituut  
P.O. Box 5059  
2600 GB Delft  
The Netherlands

Various Standards:

SIS 055900	Pictorial surface preparation standards for painting steel surfaces.
------------	----------------------------------------------------------------------



Published by:	Swedish standard commission Tegnergatan 11 Box 3295 S-10366 Stockholm
SSPC SP-8	Pickling
Published by:	Steel Structures Painting Council 4400 fifth Avenue Pittsburgh 15213 PA, USA
TRbP	Technische Regeln für Brennbare Flüssigkeiten (Technical Rules for Flammable liquids).
Published by:	Deutscher <i>Fachschriften</i> - Verlag Wiesbaden

### 3.2 Electrical Standards

Electrical apparatus for Potentially explosive Atmospheres

EN 50.014	General requirements
EN 50.015	Oil immersion 'o'
EN 50.016	Pressurized apparatus 'p'
EN 50.017	Powder filling 'q'
EN 50.018	Flameproof enclosure 'd'
EN 50.019	Increased safety 'e'
EN 50.020	Intrinsic safety 'i'
BD 384	Electrical installations of buildings

Published by:	CENELEC, European Committee for Electrotechnical Standardisation, General Secretariat 2, Rue Bréderode, B-100 Brussels, Belgium
---------------	------------------------------------------------------------------------------------------------------------------------------------------

### 3.3 Safety Standards

ISO/DIS 3864 Safety colours and safety signs

ISO 834	Fire-resistance tests of elements of building construction
ISO 3008	Fire-resistance tests - Door and shutter assemblies
ISO 3009	Fire-resistance tests - Glazed elements

Published by:	International Standardisation Organisation
---------------	--------------------------------------------

Geneva  
Switzerland

## 4. Definition of terms

For the purpose of these Regulations the following definitions shall hold:

### *Ancillaries*

The term ancillaries covers all appurtenances and system components required for the safe operation of DME storage vessels and piping systems. Ancillaries comprise items such as valves, relief valves, pumps, pressure gauges, metering equipment, controls, etc.

### *BLEVE*

'Boiling Liquid Expanding Vapour Explosion'

An explosion caused by the sudden formation and subsequent ignition of large quantities of DME vapours, normally due to rupture of a storage vessel.

### *Category I objects*

Objects designated as such:

- a) sports halls and swimming baths;
- b) shops, insofar as they do not come under Category II;
- c) hotels, restaurants, and office buildings, insofar as they do not come under Category II, as well as incidental houses, offices, and workshops present on industrial premises;
- d) playgrounds, playing fields, outdoor swimming pools, garden allotments and other recreation grounds, insofar as they do not come under Category II.

### *Category II objects*

Objects designated as such:

- a) elderly people's homes, nursing homes, hospitals and sanatoriums;
- b) schools;
- c) buildings, in which more than 5 shops are accommodated and of which the total floor area is over 1000 m<sup>2</sup>, and shops with a total floor area of over 2000 m<sup>2</sup> per object;
- d) hotels, restaurants and office buildings intended for more than 50 persons per object;
- e) telephone exchanges, buildings with flight-control equipment and other vulnerable objects of high infrastructural value;
- f) objects which through secondary effects involve increased risk, such as installations and above ground storage tanks for flammable, explosive or toxic substances;
- g) camping sites intended to accommodate more than 50 people and other recreation sites intended to accommodate more than 50 persons during a number of succeeding days per year.

*Check valve*

A check valve is a device which prevents the medium in a piping system from flowing back.

*Contractor (qualified)*

Contractor is a company which carries-out activities in the field of construction, maintenance, repair, inspection and testing of DME installations. A qualified contractor has acquired a valid certificate of registration from the Inspection Agency.

*Degassing*

Degassing is the procedure by which the gas concentration in a storage vessel and/or related piping system is safely reduced and then maintained at a level which is not higher than 10% of the lower explosion limit.

*DME*

Di-methyl ether, which is used as fuel for motorcars

*DME service station*

An establishment containing facilities where DME is stored and dispensed to motorcars.

*Dwelling*

The dwelling accommodation of a building or part of a building used for dwelling purposes or intended for such purposes.

*Excess flow valve*

A shut-off device, which provides a nearly complete automatic shut-off in case of an excessive flow rate e.g. line break.

*Filling point*

The connection point for the hose of the tank truck. At this point DME is transferred from the road tank truck to the installation. The tank truck is unloaded, the storage vessel filled.

*Fireproofness of constructional components*

The time expressed in minutes during which any constructional component, not being a door, hatch or window construction, must be capable of continuing to function during heating, determined according to Standard Specification ISO 834.

*Fireproofness of door, hatch and window constructions*

The time expressed in minutes during which construction offers resistance to collapse and remains flametight in case of fire, determined, according to Standard Specifications ISO 3008 and 3009.

*Ingassing*

The procedure by which DME is transferred into a gasfree DME storage vessel and /or piping system, thereby increasing the gas concentration up to a level well exceeding the upper explosion limit.

#### *Inspection Agency*

An institution, governmental or private, authorised to perform inspection work on a DME installation or part thereof. This includes all matters related to the engineering, fabrication, inspection and testing of such installations.

#### *Mounded storage vessel*

A DME storage vessel, installed above grade completely covered by a mound made of sand covered with tiles.

#### *Nominal diameter DN*

A numeric indication for the size of piping systems according to standard ISO-6708.

#### *Nominal Pressure PN*

A numeric indication for the pressure according to standard ISO-7268.

#### *Pressure*

The unit kPa and bar indicate absolute pressure; the expression 'gauge pressure' means absolute pressure minus atmospheric pressure.

#### *Pressure relief valve*

An automatic pressure-relieving valve actuated by overpressure in a liquid-filled system, caused e.g. by thermal expansion of the fluid.

#### *Principal*

The company which initiates and ultimately pays for the design and construction of a DME service station and hence will be involved in the control of the quality of the station's facilities and the services rendered.

#### *'Regulations'*

The Regulations for DME Service Stations and Road Tank trucks.

#### *Safety valve*

An automatic pressure-relieving valve actuated if the static pressure upstream of the valve exceeds a pre-set pressure and characterised by rapid full opening or pop action. It is used for gas or vapour service.

#### *Stoomwezen*

The Dutch governmental inspection authority 'Dienst voor het Stoomwezen' is referred to as 'Stoomwezen'. 'Stoomwezen' is the authority having jurisdiction in all matters related to the engineering, fabrication, testing, inspection, and installation of (pressure) vessels, piping and piping systems.

#### *Storage Capacity*

The net volumetric contents of a vessel when filled with water up to the maximum allowable level for DME storage.

*Underground storage vessel*

A DME storage vessel, installed below grade, completely covered by soil.

*Vessel volume*

The volumetric contents of a vessel when completely filled with water.

## 5. Definition of a DME service station

Reference is made to the following figures shown at the end of this chapter:

- Figure 5.1 Typical scheme DME service station (mounded storage);  
Figure 5.2 Typical scheme DME service station (underground storage);  
Appurtenances list for figures 5.1 and 5.2:
- Figure 5.3 Typical mounded storage vessel;  
Figure 5.4 Typical underground storage vessel;  
Figure 5.5 Simplified control system

### 5.1 General

The prime function of DME service stations is to distribute DME to motorvehicles. To serve this purpose a typical station comprises:

- one or two DME storage vessels, either mounded or installed underground;
- one or two DME filling points for supply by road tank trucks;
- one or more DME dispensing columns;
- a sales room;
- interconnecting piping and cabling;
- operation control and safety systems.

A DME service station may be combined with facilities for the distribution of other automotive fuels to consumers, where as also additional features as e.g. car washing facilities may exist on the premises.

The properties of DME are given in Appendix I.

DME is supplied, stored and delivered as a liquid, at ambient temperature and under its own vapour pressure. When DME escapes, through leakage or otherwise, it evaporates quickly, expands to about 350 times its liquid volume and spreads out at ground level as DME is heavier than air. A basic lay-out requirement therefore is the avoidance of places below ground level and of lowly placed ventilation openings for buildings.

Specific location and lay-out requirements for DME service stations are given in chapter 6.

### 5.2 DME storage facilities

At a DME service station the DME is either stored in “mounded pressure vessels” i.e. pressure vessels which are located above grade and completely covered with sand or in underground pressure vessels, to provide protection against external

heat from sun radiation or fire. Temporarily installed vessels shall never be used for DME storage.

If required two vessels can be installed, each having its own related piping systems which must be completely separated from each other.

Each DME storage vessel with its appurtenances as safety valves, level instruments, block valves etc., is electrically isolated from any related piping when either the vessel or the piping systems are provided with a separate cathodic protection system.

For reasons of safety and economy, the storage capacity of each vessel should be sufficiently large to receive the contents of a road tank truck in its entirety. The frequency of loading by road tank trucks can thus be kept to a minimum.

In and outlet piping is provided with manually operated block valves and remotely controlled block valves.

Remote control shall be possible at least from two different locations.

All nozzles for piping and instrument connections are located on the manholes. An exception is made however for mounded vessels where the outlet nozzles connected with the delivery system are located in the fronthead, well below the lowest liquid level.

By comparing the heat of combustion of propane and DME it can be concluded that the energy contents of propane (24.1 MJ/dm<sup>3</sup>) is 26.8 percent higher than the energy contents of DME (19.0 MJ/dm<sup>3</sup>). This means that if the availability of energy for DME should be the same as for propane, the storage vessels of DME should be larger (26.8%) or DME should be delivered more frequently.

### 5.3 DME filling system

The discharge of DME from road tank trucks into a storage vessel is based on the principle of bottom unloading without usage of a vapour return line.

The tank trucks carry their own pump/meter units and discharge hoses. The trucks hoses shall be used for filling only.

The station's filling point is located in the vicinity of, but at a safe distance from, the DME storage area.

Each storage vessel is provided with an overfill protection system which automatically initiates closure of the remote controlled inlet valve when the maximum allowable level in the storage vessel has been reached (86 vol%) and no manual action has been initiated previously by the driver of the road tank truck. This percentage is based on the increase of liquid volume within the design temperature range which runs from -20° ( $\rho = 720.3 \text{ kg/m}^3$  [2]) up to 50 °C ( $\rho = 620.3 \text{ kg/m}^3$  [2]). From the above it can be concluded that the increase of volume is 16.2 % through which the maximum filling degree is limited to 86 %.

The driver can follow the filling progress on a level indicator installed adjacent to the filling point and is warned by a signal when a filling level of 81 % has been



reached. This will give him sufficient time to stop the unloading of DME, ultimately when the 86% filling rate of the vessel has been reached.

Due to the very poor conductivity of DME the filling point is earthed to discharge any static electricity. The filling point is electrically insulated from the buried piping of the filling system by means of an insulation joint.

A bonding cable of the road tank truck is connected with a receptacle in a weather proof cabinet adjacent to the filling point. Receptacle and filling point are interconnected to ensure equi-potential between truck and filling point during unloading.

Plugging-in of the bonding cable into the receptacle of the cabinet also connects the truck's ESD system with the station's facilities (see § 5.5). With a further provision at the filling point (e.g. a key switch) the remote-controlled filling valve may be opened.

Pressure relief valves protect line sections against overpressure, if DME is blocked-in by closed valves.

To avoid unloading of the wrong substance the fitting for unloading DME should be unique.

#### 5.4 DME dispensing system

DME supply to consumers is arranged via one or more dispensing columns located on one or more 'pumping islands'. Each dispensing column may have one or two delivery points, each having its own metering, appurtenances and piping.

Electric motor driven transfer pumps, installed either inside a storage vessel or adjacent to a vessel provide for DME supply to the delivery points. Normally one pump is installed for each point, but a system whereby one pump serves two delivery points is feasible. Each pump is protected from pumping against closed discharge by a by-pass/overflow line leading back to the storage vessel.

The delivery lines are provided with DME-gas, air or electric actuator operated valves which remotely isolate the system in case of an emergency. Line sections which can be blocked-in by valves are provided with pressure relief valves; the buried pipe sections are electrically isolated by means of isolating joints in case the vessel and/or these pipe sections are provided with a cathodic protection system.

At a dispensing column, the DME is filtered, the vapour separated and the liquid quantity supplied to the consumer measured by a flowmeter. Any vapour is disposed via a vapour return line leading back to the storage vessel.

The DME in the pipe section downstream the flowmeter up to the delivery hose is blocked-in when no delivery takes place. Since protection of this pipe/hose section by means of a relief valve is not feasible in this case, protection is provided by an expansion vessel.

A filling operation can only be started and maintained by pressing a so-called dead man's push button. Release of this button terminates DME delivery immediately by stopping the pump or, in case one pump serves 2 delivery points, by closing a block valve of the delivery point concerned.

## 5.5 Operation control and safety systems

### 5.5.1 General

The operational status of a DME service station can be as follows:

#### Normal status:

The service station is ready for deliveries to customers and prepared to receive DME supply from road tank trucks if required.

#### Stand-by status:

The service station is closed, personnel is not present, however receiving DME should still be possible. All remote-controlled valves are closed.

#### Non operational status:

The DME service station is completely shut-down, e.g. in case of maintenance or an emergency shut-down (ESD) situation. All remote-operated valves are closed and the installation de-energised.

### 5.5.2 Electrical control system

The above described situations are indicated and controlled by an electrical circuit which comprises the following major items:

- Main control panel: the panel is equipped with a main key operated switch controlling the operational status and related indicating lights showing the status.  
Furthermore the panel contains the motor control for the DME transfer pumps and the level alarm/ indicating and controlling equipment.
- Weatherproof cabinet adjacent to the filling point, containing a key operated switch, a receptacle for the truck's ESD-system and earthing connections, a level indicator and level alarm.
- At least 2 emergency shut-down push-buttons, one located in the salesroom, the other one near the dispensing area.

### 5.5.3 Operation

Reference is made to figure 5.5: 'Simplified control system', shown at the end of this chapter.

#### During opening hours

The DME service station becomes operational by switching the key operated switch at the main control panel. The control system is energised now and the station ready for operation. The remote-controlled block valves in the motorcar delivery lines, the vapour return lines and the transfer pump by-pass lines are open, the remote-controlled block valve in the filling line is closed.

Filling of the storage vessel by the driver of the road tank truck is possible, when done in accordance with the filling operation as outlined below.

#### During closing hours

When no personnel is present, filling the DME storage vessels still can be made possible by switching the key operated switch at the main control panel to 'Stand-by'. In this situation the driver of an incoming road tank truck can, by following the same filling operation, energise the part of the station's electrical circuit which is required to perform the filling operation.

Delivery to motorcars however is not possible since the remaining electrical circuits are still de-energised.

#### Filling operation: (see figure 5.5)

The filling operation to be performed by the driver of an incoming tank truck comprises:

- a) connecting the ESD system of his road tank truck with the ESD system of the station and
- b) activating the remote-controlled valve in the filling line.

The required activities should be carried-out in a certain sequence.

The driver of the road tank truck should:

1. Connect the plug of the road tank truck's connecting cable to the receptacle of the service station (this includes earthing).
2. Connect the filling hose of the truck to the service station
3. Ascertain that the road tank truck's own control system is activated. If so, a contact in the ESD loop of the road tank truck will close and energise relay A (located in the service station). Relay A being energised will:
  - Establish a by-pass over the key operated switch in the ESD loop of the service station.
  - Switch on the green light.
4. Insert the key into the key operated switch and activate the circuit. This operation will:
  - Interconnect the ESD system of the truck with that of the service station.

- Open the DME filling valve.
5. Pumping may now commence.

To discontinue the filling operation the above actions must be reversed. It should be noted that:

- Any malfunction either on the truck or in the filling station will give an ESD.
- Operating the key switch before having plugged in the control plug of the truck into the receptacle will give an ESD.
- Disconnecting the plug before having de-activated the key operated switch will give an ESD.

#### 5.5.4 Automatic overfill protection/level control

Each storage vessel is provided both with a local level indicator and a combined overfill protection/level alarm and control device connected with the level indicator installed adjacent to the filling point. The setting of the alarm shall be such (81 %) that the driver of the unloading road tank truck has sufficient time to stop the unloading, that is before the maximum filling level of 86 % in the vessel has been reached (see also § 5.3).

If no manual action has been taken previously and the maximum allowable filling level has been reached, the overfill protection device initiates an automatic termination of the unloading by closing the motor-operated valve of the filling system, which for this purpose is controlled independently from the other ESD valves.

A failure of the overfill protection device results automatically in a closure of the remote-operated filling valve, hence filling by road tank trucks is not possible anymore.

Low liquid level automatically stops the DME dispensing pumps and closes the remote-controlled valves of the dispensing system: motorcars cannot be filled anymore.

#### 5.5.5 Emergency shut-down system (ESD)

The shut-down system comprises a system by which the storage vessels can be fully isolated from the inlet and outlet piping systems. These 4 systems i.e. supply piping, the piping for deliveries to motorcars, vapour return from the dispensing column and transfer pump by-pass are provided with remote-controlled block valves equipped with single acting spring return actuators ('fail safe'). The valve actuators are either operated by DME or compressed air; also electrically activated actuators are quite common.

When initiated by an ESD push-button in case of an emergency, the electric circuit of the station's facilities is de-energised and all actuators close the valves at the same time within 15 seconds.

Also the dispensing pumps will stop and cannot be restarted unless the valves are re-opened. ESD push-buttons must be located at least in the salesroom, and at the dispensing area.

Furthermore provisions must be made to enable initiation of an ESD of the DME service station valves from the ESD push-buttons of the unloading road tank truck. This can be achieved by connecting the electric circuit of the truck with the station circuit, as described under § 5.5.3. In case of an emergency during unloading, the remote controlled valves of the DME service station thus close automatically and simultaneously with a shutdown of the tank truck's own facilities.

Without this connection between the electrical circuits filling of the station's vessel will not be possible, as the filling valve of the service station remains closed.

### 5.5.6 Valve control systems

#### DME-operated valve actuators:

The gas in the control system, keeping the valve actuators in an open position, is provided from the DME storage vessel via tubing. The actuators are controlled by solenoid valves: one solenoid valve controls the valves of the motorcar delivery, vapour return and transfer pump by-pass lines, another solenoid controls the remote controlled valve in the filling system, which should be operated independently to enable DME filling during closing hours. Before entering the control system, the gas pressure is reduced to approximately 1.0 barg.

By pushing an ESD-button, both solenoid valves are de-energised and the gas pressure in the gas supply system to the actuators released.

#### Compressed air-operated valve actuators:

This control system is similar to a DME control system: only compressed air is used instead of DME. The compressed air is supplied by a small electric motor driven air compressor.

#### Electrically-operated valve actuators:

The valves are controlled by electric actuators. Also in this case de-energising of the electric circuit results in a spring actuated closure of all valves.

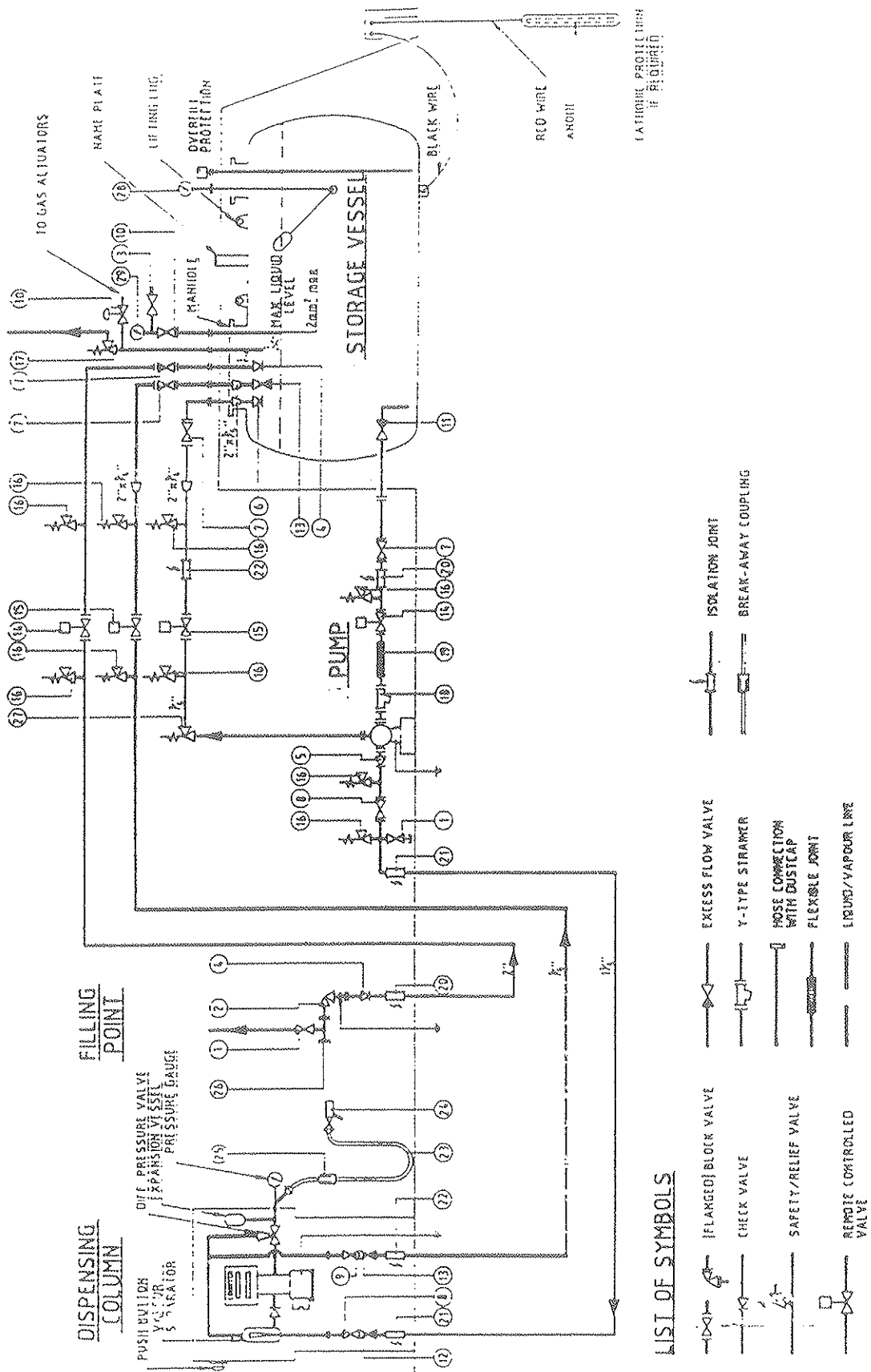

Figure 5.1 Typical scheme DME service station (mounded storage)

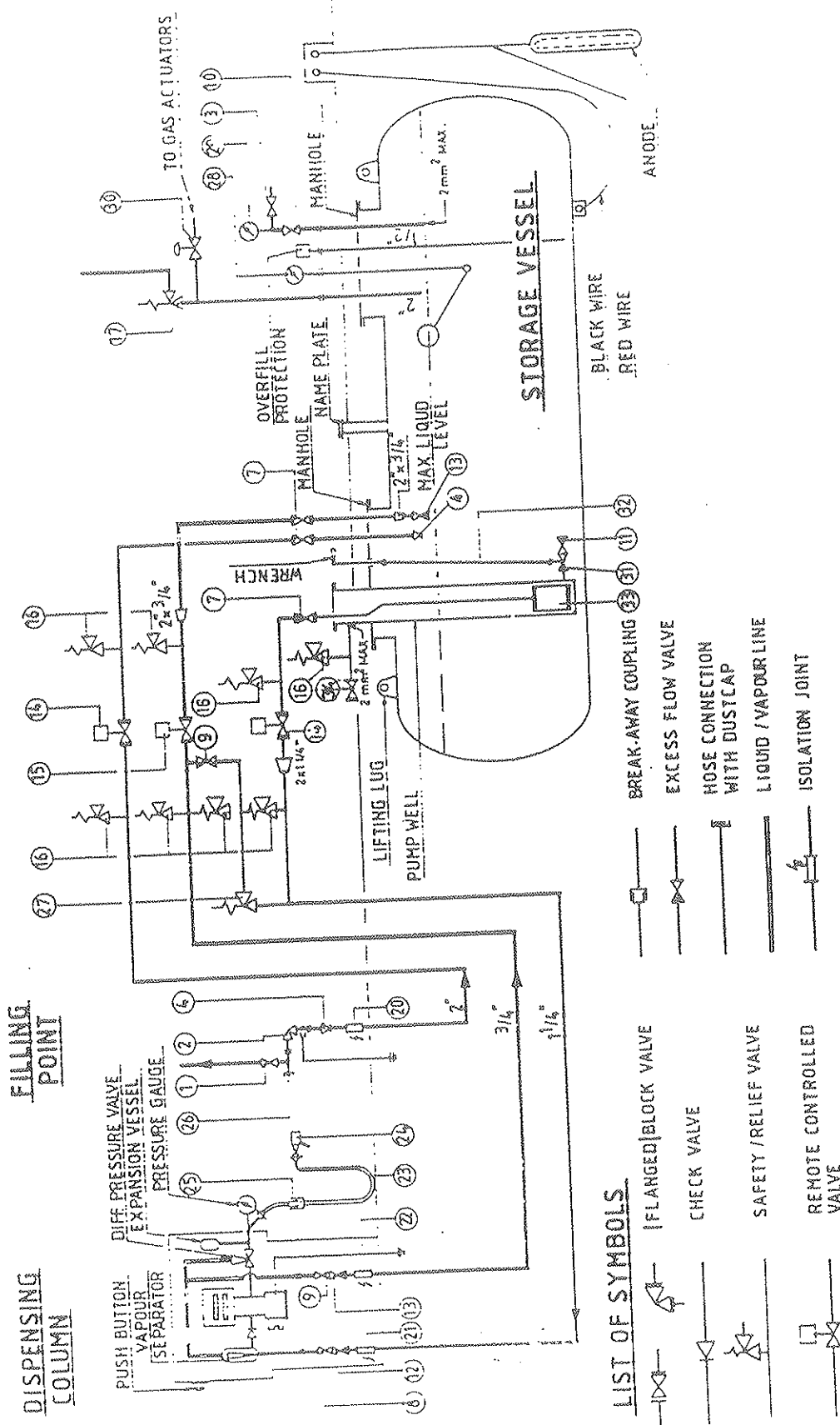

Figure 5.2 Typical scheme DME service station (underground storage)

List of appurtenances as shown on typical schemes of DME service stations  
(figures 5.1 and 5.2)

Identification nr	Description	Number of items		Size (inch)
		Fig. 5.1	Fig. 5.2	
1	Blow-off valve	2	1	½
2	Angle valve	1	1	2
3	86% ullage valve	1	1	½
4	Check valve	2	2	2
5	Check valve	1	-	¼
6	Check valve	1	-	¾
7	Block valve	4	3	2
8	Block valve	2	1	1¼
9	Block valve	1	3	¾
10	Block valve	1	1	½
11	Excess flow valve	1	1	2
12	Excess flow valve	1	1	1¼
13	Excess flow valve	2	2	¾
14	Remote control valve	2	2	2
15	Remote control valve	2	1	¾
16	Relief valve	9	8	¼
17	Safety valve	1	1	-
18	Strainer	1	-	2
19	Flexible joint	1	-	2
20	Insulation joint	2	1	2
21	Insulation joint	2	1	1¼
22	Insulation joint	2	1	¾
23	Filling hose	1	1	¾
24	Filling nozzle	1	1	¾
25	Break-away coupling	1	1	¾
26	Hose-connection with cap	1	1	3¼
27	Overflow/relief valve	1	1	¾
28	Level indicator	1	1	-
29	Pressure gauge	1	1	½
30	Pressure control valve	1	1	¼
31	Ball valve	-	1	2
32	Articulated stem extension	-	1	-
33	Submerged pump	-	1	-
34	Vent of pump well	-	1	¼



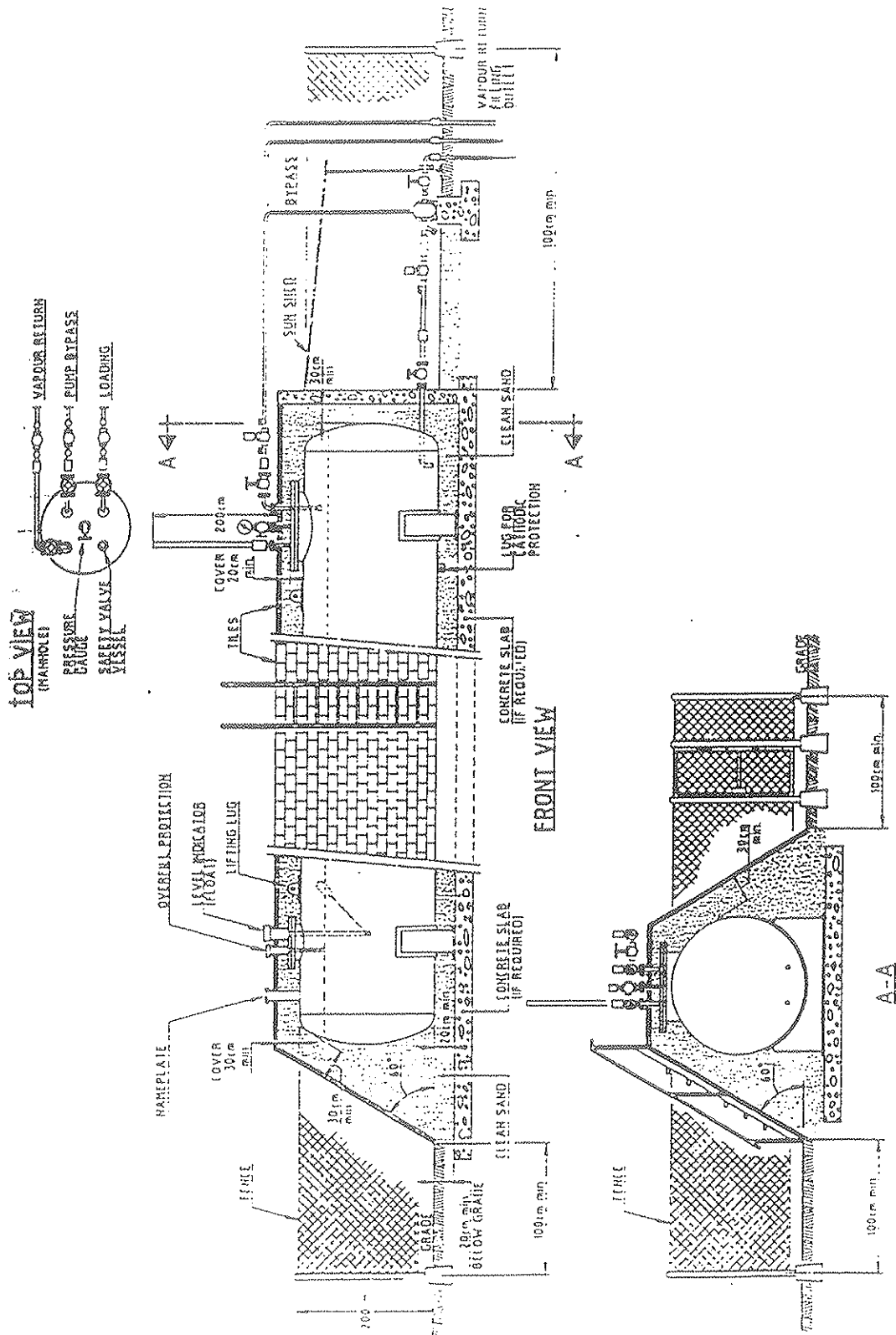

Figure 5.3 Typical mounded storage vessel

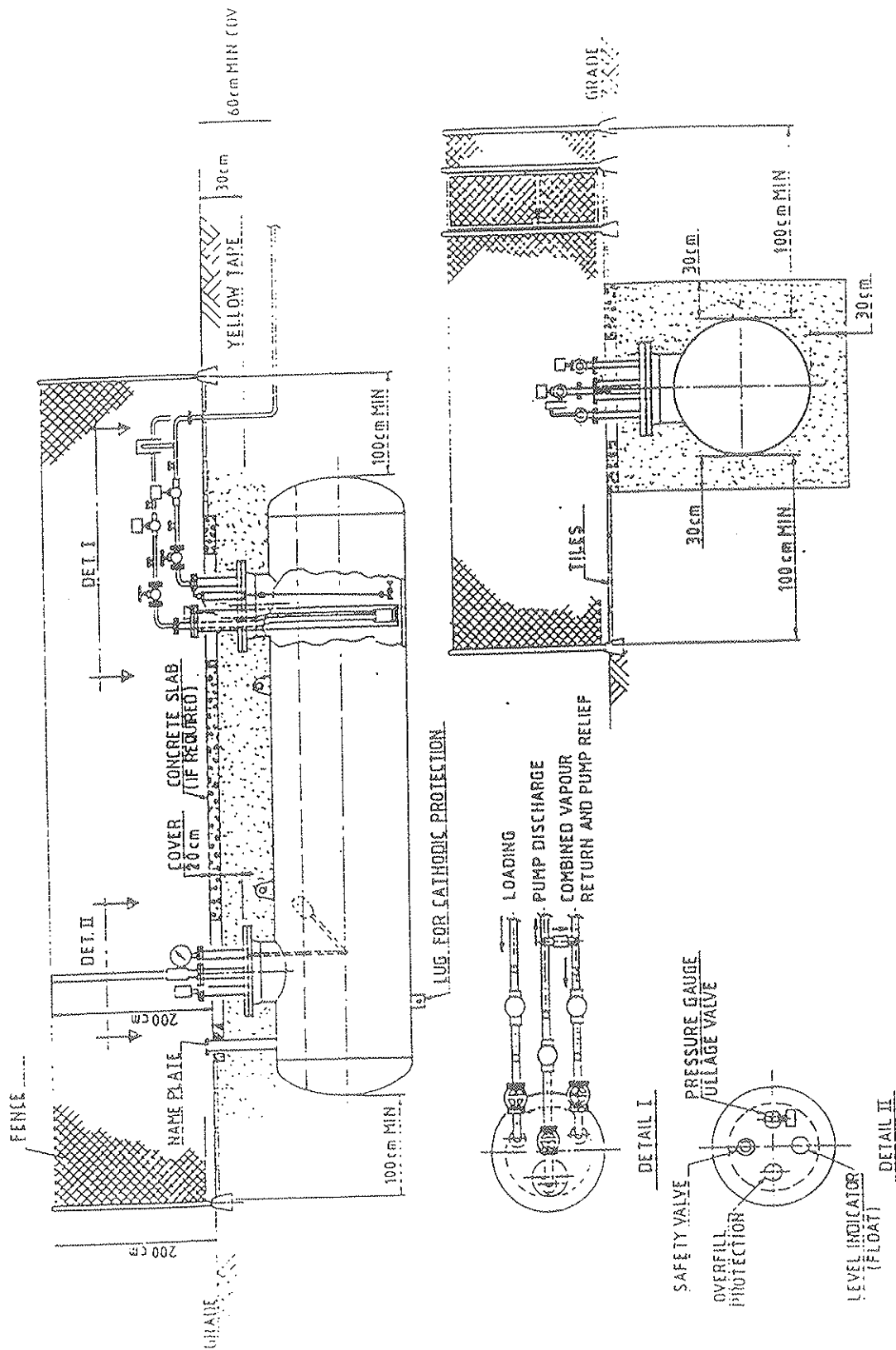

Figure 5.4 Typical underground storage vessel

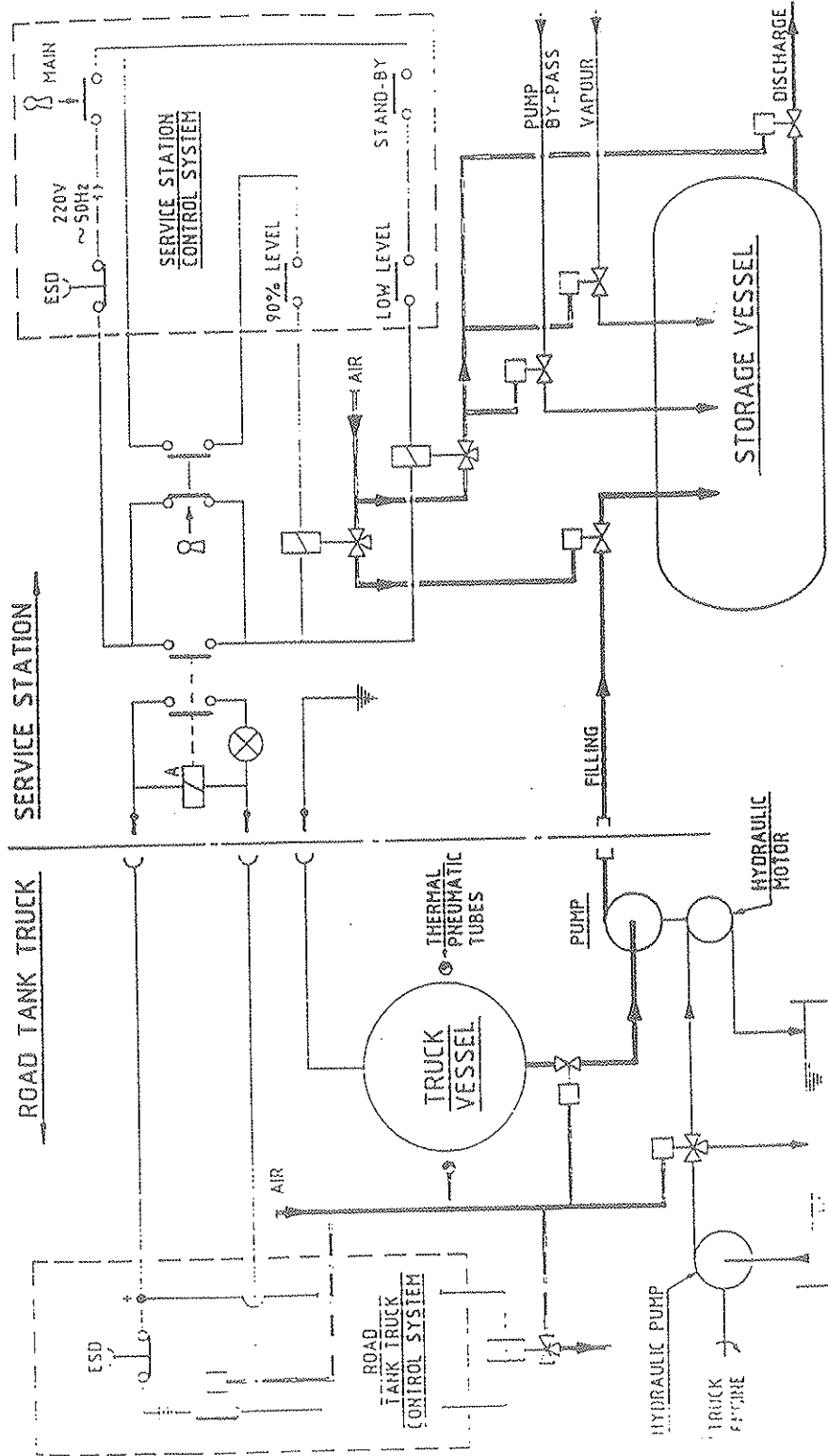

Figure 5.5 Simplified control system

## 6. Location and layout criteria

### 6.1 Location

DME service stations shall be located along designated highways which are considered to be safe for DME transport, or at locations which can be easily reached from these highways without passing residential areas, individual apartment buildings or single objects of category II (as defined in chapter 4).

This is assumed to be the case if, after having left the highway, the road tank truck will not pass at any point on his route more than 15 dwellings or any single objects of category II being located within 80<sup>(\*)</sup> metres distance, measured from the centreline of the road.

*Note: (\*) This distance is based on effect calculations resulting from a ignited release of LPG by using the Yellow Book [3]. Due to the fact that the heat of combustion of LPG (24.1 MJ/dm<sup>3</sup>) is approximately 1.3 times the heat of combustion of DME (19.0 MkJ/dm<sup>3</sup>) the given distance is somewhat conservative for DME.*

### 6.2 Lay-out

Reference is made to figure 6.1, 'Typical lay-out of DME service station alongside main road (1500 m<sup>2</sup>)' and to figure 6.2, 'Typical lay-out of DME service station alongside secondary road (750 m<sup>2</sup>)', shown at the end of this chapter.

These lay-outs are typical only, based on rectangular shaped installation areas and mounded storage vessels. Many variations are possible, including some area reduction, depending on the shape and location of the available area.

#### 6.2.1 General

The following points shall be observed:

The lay-out of a DME service station shall ensure unobstructed access and departure of consumers and of supply vehicles at all times.

Entrance, exit and paving shall be arranged in a manner which minimises the risk of collisions.

The operating personnel shall have an unobstructed overall view on the facilities, both from the salesroom and from the delivery area.

An exactly designated and marked unloading location for road tank trucks shall ensure that these trucks neither hinder other traffic nor obstruct a good overall view on the facilities of the DME service station and/or hamper its operation.

Safety facilities such as escape routes, means for emergency shut-down and fire-fighting equipment shall be provided.

#### 6.2.2 Minimum and maximum plot size

The plot size will depend on location, volume of storage, number of selling points for automotive fuels, side-activities planned as e.g. car washing facilities, etc. Minimum allowable distances between individual facility items as described in § 6.3 and general arrangement considerations will lead to a minimum required plot size.

Other considerations as the overall view requirement and the length of interconnecting piping and cabling between the DME facilities, lead to a maximum plot area, the size of which again depends on the extent of the services to be rendered.

In each case however, all installation items, including piping, shall be situated within a circle with a diameter of 400 m. maximum. *[There is no reason to change the requirement that all equipment should be within a radius of 400 meter for DME.]*

#### 6.2.3 Accessibility of ancillaries

Ancillaries and components of the DME-filling, storage and dispensing systems such as valves shall be easily and safely accessible and operable. This applies also to indicating instruments and all parts requiring regular inspection and maintenance.

#### 6.2.4 Protection against collision

The location of storage vessels, pumps, filling point with cabinet, dispensing columns etc. shall be such that the danger of collisions by motor vehicles is minimised. If such a location is not feasible, the equipment concerned shall be suitably protected, either by a crash barrier as used on highways or by concrete filled steel poles, having a diameter not less than 100 mm. The poles shall extend 0.6 metre above grade and be well anchored in the soil which shall be raised 0.1 m and paved. The border of the paving shall extend the poles by at least 0.1 metre. The distance between any two poles shall not be more than 1.0 metre.

#### 6.2.5 Installation of storage vessel(s) and pump(s)

The storage area including the pumps and related piping shall be surrounded by a fence if the storage area is located on an area which can be entered unchecked by unauthorised persons.

The fence shall be installed at least at 1 metre distance from the foot of the mound or - in case of underground vessels - from the horizontal projection of the vessel(s). The fence shall have a minimum height of 2 metres and shall consist of sturdy metal meshwork of 50 mm maximum mesh, made of wire of at least 2 mm thickness.

Two doors shall be provided, being located in two opposite sides of the fencing. The doors shall open to the outside and be provided with locks which can be opened from the outside only with a key and from inside the fencing without a key.

The storage and pump area inside the fencing shall be paved either with tiles or concrete. The area inside the fence shall not be used for storage of any goods. The pump(s) shall be installed in the open air. The pump(s) and related piping shall be protected by a removable sun shed.

#### **6.2.6 Installation of dispensing-column(s)**

The dispensing column(s) shall be protected against collision by means of concrete filled poles as described under § 6.2.4. Furthermore permanent provisions are required to protect the dispensing columns against direct radiation of the sun, e.g. by individual or common sunshades. The dispensing columns shall be placed on paved "islands", so that motorcars can park on both sides. During filling with DME, motorcars shall not stay on the main road. Thus the pumping islands shall be located accordingly.

#### **6.2.7 Buried piping and cables**

Piping and cables shall be buried at a depth of at least 0.6 metres below grade in a completely surrounding layer of clean sand. No piping shall be laid under buildings.

### **6.3 Minimum on-plot distances**

Reference is made to figure 6.3, 'Minimum distances for DME service stations', and to Appendix XIII 'Checklists for inspection of DME service stations'.

#### **6.3.1 General**

There is always a certain risk involved in the handling of DME. The risk of occurrence of the most serious hazard, a 'BLEVE' of the storage vessel, is practically eliminated by coverage with a mound of sand.

In spite of technical safety measures specified in this regulation other hazards remain possible, e.g. ignition of quantities of escaping gas, formation of gaseous clouds at low places, fire in other storage tanks containing flammable goods.

In order to reduce the risk of occurrence of any of such hazards, minimum allowable distances have been specified in the next paragraphs, which shall be strictly adhered to.

### **6.3.2 Distance towards low-lying places**

No cellar openings, gullies and suction openings of ventilation systems situated at less than 1.5 m above grade may be present within 15 metres from the horizontal projection of the storage vessel, the filling point or from a dispensing column [4].

### **6.3.3 Distances to prevent ignition of small quantities of escaped gas**

Electrical equipment to be installed or used within the hazardous area zones 0,1 and 2 shall be of adequate explosion proof design as described in chapter 10 'Electrical Requirements'. The zonal areas around storage vessel, filling point and dispensing column are depicted on figure 10.1: 'Hazardous area classification' in the same chapter.

The distance between the DME filling point and a building or dwelling on the site, as well as to the site boundary, the weatherproof control cabinet, the salesroom and any dispensing column for DME or automotive fuel shall be at least 5 metres [4].

The distance between the tank truck area and a building or dwelling on the site as well as to the salesroom and any dispensing column for DME, gasoline or diesel shall be at least 5 metres [4].

The distance between the horizontal projection of the storage vessel and the salesroom, the site boundary as well as any dispensing column and any motorcar to which automotive fuel is being delivered, shall be at least 5 metres [4].

The distance between any dispensing column and the site boundary, the storage vessel, the tank truck area and the DME filling point shall be at least 5 metres [4].

The distance between any DME dispensing column and the salesroom as well as any building or dwelling on the site shall be at least equal to the maximum length of the DME delivery hose plus 2 metres, which is 7 metres minimum.

### **6.3.4 Distances in connection with protection of objects in case of-escape and/or fire of major quantities of DME.**

The distance from the horizontal projection of the storage vessel to a building or dwelling belonging to the establishment shall be at least 15 metres [4]. If walls and the roofing of these buildings within a distance of 15 metres [4] (measured both

horizontally and vertically) from the vessel have a fire-resistance of at least 30 minutes, this distance shall be at least 7.5 m.

The distance from the horizontal projection of the vessel, from the filling point and from the location for the tank truck to above-ground storage of other hazardous substances in quantities of more than 100 litres shall be at least 15 metres, unless the storage of these substances takes place in a building of which the walls and the roofing within a distance of 15 metres (both horizontally and vertically) from vessel, filling point or location for the tank truck have a fire-resistance of at least 60 minutes. In that case the distance shall be at least 7.5 metres [4].

The distance between the horizontal projection of the vessel and the filling point or between the vessel and the tank truck unloading area shall be at least 15 metres [4].

### 6.3.5 Distances to avoid damage to coating of DME vessels

The distance between two DME storage vessels in one common mound, or both installed underground or between mounded DME storage vessel and any other buried vessel shall be at least one (1) meter.

### 6.3.6 Location of DME road tank trucks

During unloading the tank truck shall be placed at maximum 5 metres distance from the filling point, facing the direction of departure, in such a way that in the event of an emergency it can move off to the public road without manoeuvring.

In case of a DME service station situated along a road, where a speed limit of more than 50 kilometres per hour is in force, the location for the tank truck may not be on this road, on the hard shoulder or lay-by alongside the road or alongside the part of the road that gives access to the station.

## 6.4 Minimum distances to off-plot objects

The distance from DME filling point and road tank truck area to objects category I shall be at least 30<sup>(\*)</sup> metres, to objects category II and third party dwellings minimum 80<sup>(\*)</sup> metres.

The distance from the storage vessel(s), to be measured from the horizontal projection of the vessel and the pump, to objects category I shall be at least 20<sup>(\*)</sup> metres, to objects category II and third party dwellings 40<sup>(\*)</sup> metres.

The distance between DME dispensing columns and all category I and II objects and dwellings shall be at least 20<sup>(\*)</sup> metres.



The distance from storage vessel, filling point, tank truck and dispensing columns respectively towards any off-plot buildings shall be at least the distance as stipulated for on-plot buildings.

The distance of DME piping to off-plot objects shall be at least 5<sup>(\*)</sup> metres.

Notes:

- Object category I and II and dwellings have been defined in the chapter 'Definition of terms'.
- Buildings in this context are defined as objects other than category I or II objects or dwellings, e.g. usually unoccupied sheds or store houses for non-dangerous goods.
- For distances marked with a '(\*)' reference is made to the note as given in § 6.1).

A graphical survey of required distances is given in figure 6.3 at the end of this chapter.

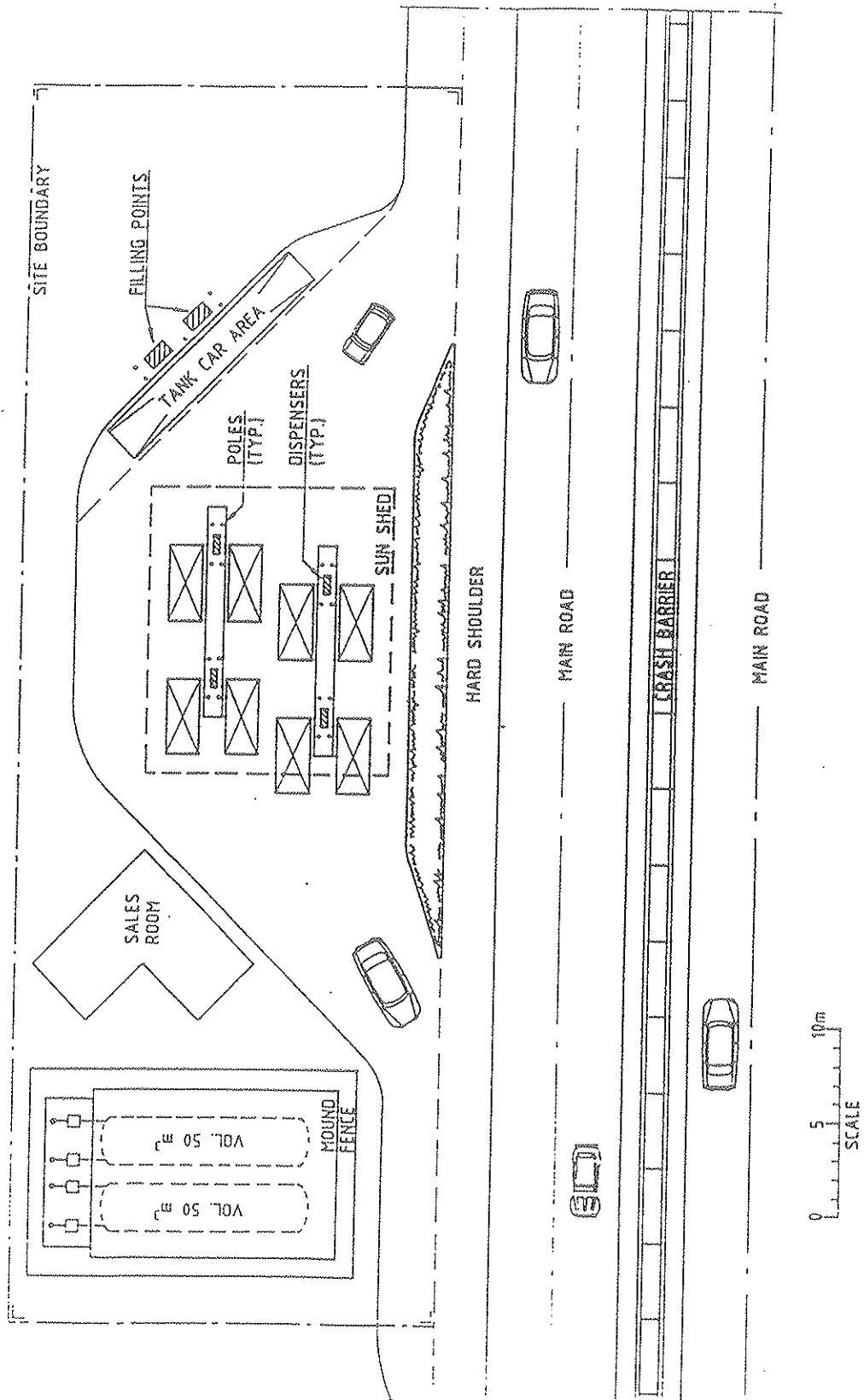

Figure 6.1 Typical layout DME service station alongside main road (1500 m<sup>2</sup>)

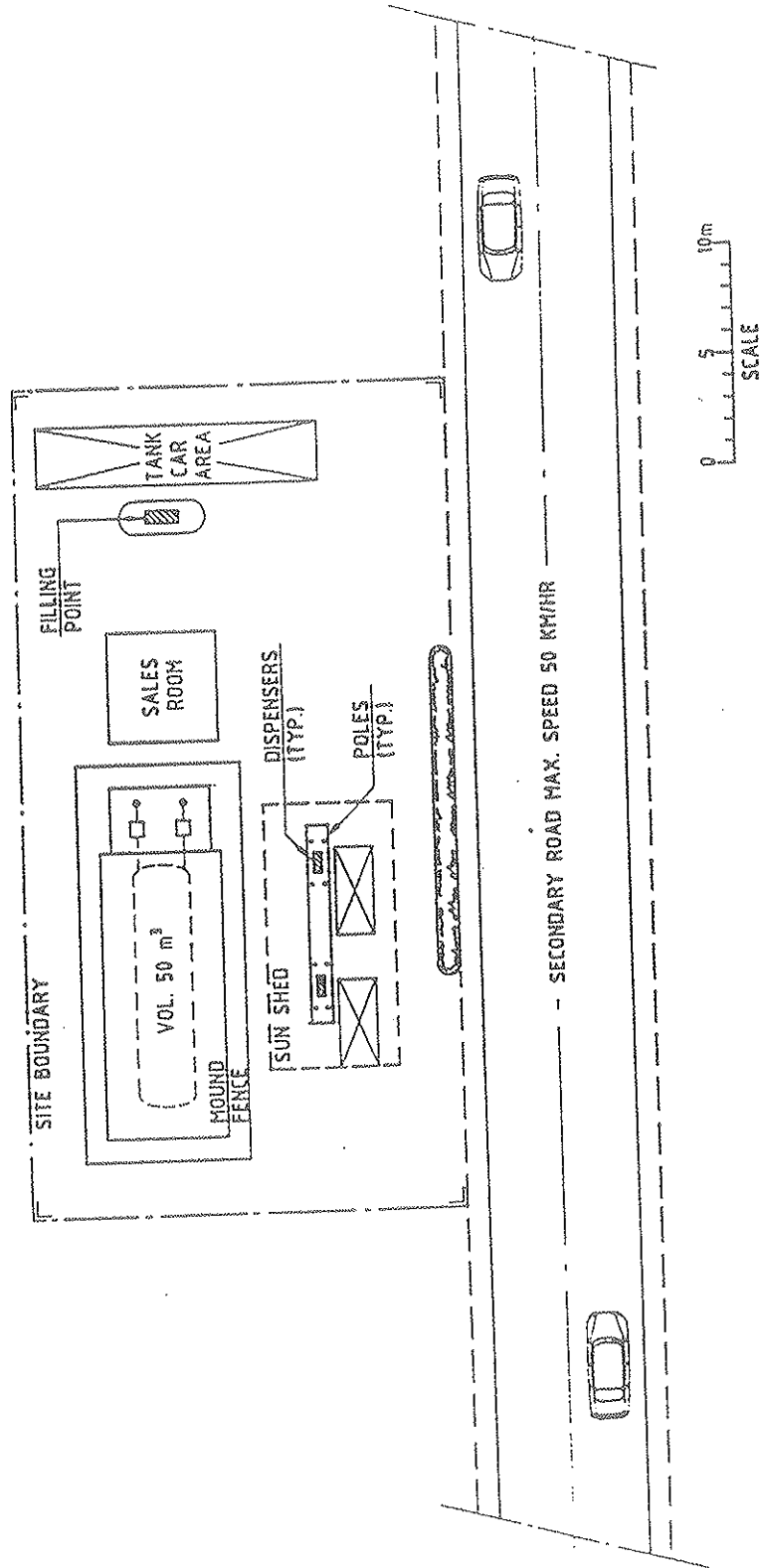

Figure 6.2 Typical lay-out DME service station  
Alongside secondary road (750 m<sup>2</sup>)

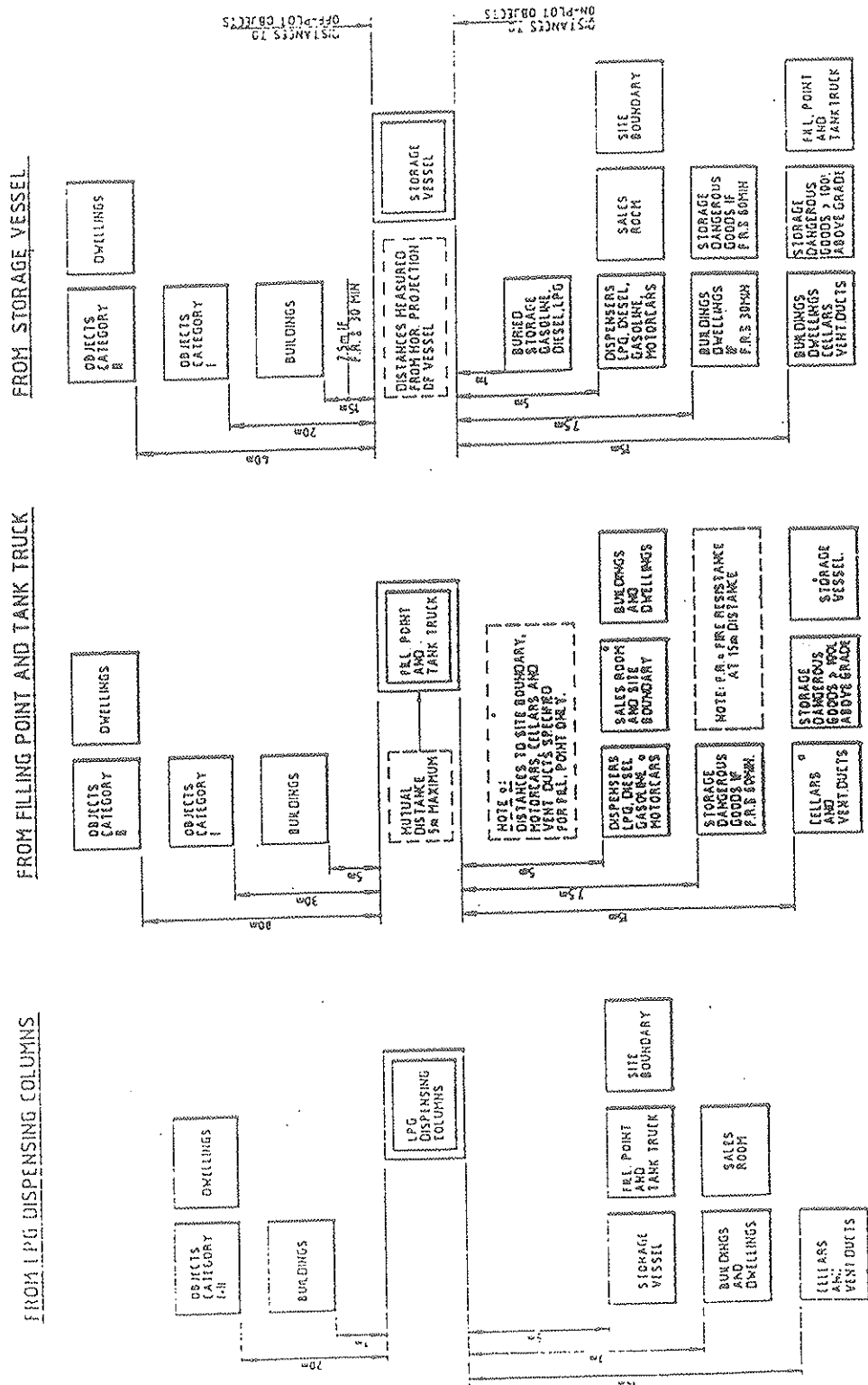

Figure 6.3 Minimum distances for DME service station

## 7. Requirements

In this chapter the requirements are given for the design, fabrication, inspection and testing of stationary mounded or underground storage vessels and related appurtenances for the storage of DME at DME service stations.

### 7.1 Design codes and regulations

DME storage vessels are classified as unfired pressure vessels, which are subjected to the inspection and acceptance of the Inspection Agency.

DME storage vessels shall be designed, fabricated and tested as a minimum in accordance with the ASME section VIII 'Boiler and Pressure Vessel Code' division 1, or with BS 5500, both supplemented with the requirements of these 'Regulations'.

These vessels shall be installed either above grade in a mound of sand or installed underground (buried) and shall only be used for the storage of DME.

### 7.2 Vessel volume

DME storage shall be of adequate capacity to receive the complete contents of one DME tank truck. The volume of the vessel therefore shall be preferably equal to the volume of a road tank truck plus 20%, with a maximum of 50 m<sup>3</sup> and a minimum of 20 m<sup>3</sup>. *[Due to the fact that the energy contents of DME is lower than the energy contents of LPG (see § 5.2) there might be a reason to enlarge the storage vessels.]*

A maximum of 2 vessels may be installed either mounded or underground in one DME service station. The total vessel volume shall not be more than 100 m<sup>3</sup>. In case two vessels are installed, both vessels shall have equal dimensions and the vessels shall not be interconnected.

### 7.3 Design and test pressures

The design pressure shall be equal to the maximum vapour pressure of DME at an ambient temperature of 323 K (50 °C) which amounts to approximately 11.5 barg. The hydrostatic test pressure shall be 1.3x the design pressure = 15 barg.

Note:

In case of an ambient temperature of 253 K (- 20 °C) during wintertime the pressure in the vessel decreases to approximately 120 kPa. Therefore, for this situation no design pressure below atmospheric pressure has to be specified.

## 7.4 Design temperatures

The maximum design temperatures shall be 323 K (50 °C) respectively. The minimum design temperature depends on the local ambient conditions and/or the requirements of the authorities having jurisdiction. In the Netherlands the minimum design temperature amounts to 253 K (-20 °C).

## 7.5 Material

DME is incompatible with most elastomers. Therefore, DME storage vessels shall be manufactured from a material which is DME resistant; carbon steel or low alloy-steel, e.g. ASTM A-285C, A-515 GR.55 or 60, DIN 17155 H II or similar material which must be suitable to meet the mechanical properties at the minimum design temperature and be made in accordance with an officially accepted material specification and made as described in the ISO (International Organisation for Standardisation) standards ISO 2605 and 6303 and in the CEOC (Colloque Européen des Organismes de Contrôle) standards R25/CEOC/79, R26/CEOC/79 and R29/CEOC/83).

A procedure for acceptance of manufacturers may be found inter alia in the following document of the CEOC (Colloque Européen des Organismes de Contrôle): R49/CEOC/83 Approval of manufacturers of fittings and flanges.

## 7.6 Design

The design of DME-storage vessels shall be at least in accordance one of the codes specified in § 7.1 and as stated hereafter.

One general requirement with regard to the design is the type of material used for the system. The parts of the system which come into contact with DME should be DME resistant due to the fact DME attacks most elastomers.

A second requirement is that the system should be designed to withstand the maximum possible operating pressure within the system. *[It is assumed that the supplier of the equipment specifies the requirements of the equipment based on the maximum operating conditions of the system.]*

For the appurtenances as mentioned below the following complementary measures should be taken.

### 7.6.1 Nozzles, manholes, vent openings

Each vessel shall be provided with either two circular manholes or one manhole and one vent opening which shall be located on top of the vessel at a maximum distance from each other. The vessel shall not have any other openings or connections except the discharge nozzle(s) of mounded storage vessels which may be located in the front head.

Manholes shall have an internal diameter (ID) of 600 mm; vent openings to have an ID of at least 150 mm.

### 7.6.2 Connections

Each DME storage vessel shall be equipped with flanged connections (nozzles) for:

- a) one or more spring loaded safety valves;
- b) a maximum ullage valve, mounted on a pipe with a built-in restriction having an I.D. of max. 1.8 mm<sup>2</sup> (based on a maximum nominal diameter of 1.5 mm), the pipe has to be extended to the maximum allowable liquid level;
- c) a level indicator (optional if the equipment mentioned under i) provides level indication);
- d) a manometer. (preferably combined with b) above);
- e) the discharge of liquid DME (one or two nozzles);
- f) the filling of liquid DME;
- g) a vapour return line from the dispensing column;
- h) a pump by-pass line;
- i) an overfill protection/level control device.

Each connection must have a minimum nominal size of 50 mm except for pipe connections having an opening of 1.8 mm<sup>2</sup> based on a nominal diameter of 1.5 mm. All connections (except the discharge nozzles of mounded storage vessels) shall be located on the manholes and/or vent opening, have a sufficient length to protrude the sand cover on the outside of the vessel and be provided with a flange.

In case two vessels are installed, their piping systems shall be kept fully separated.

### 7.6.3 Flanges

All nozzles shall have welding neck flanges, pressure rating PN 40, in accordance with DIN 2635, BS-4504 or equivalent. Manholes and vent openings shall have welding neck flanges PN 25 as per DIN 2634, BS-4504 or equivalent. All flanges to be provided with a suitable facing to prevent blow-out such as ring type joint facing, male/female facing as per DIN 2513 type R 13 (cover facing type V13) ; raised face flanges are also acceptable when safe gaskets with steel rings are used.

Flange material: carbon steel C22 as per DIN 17200 or equivalent. All flanges shall be through-bolted with stud bolts. (flanges with studs are not acceptable).

### 7.6.4 Bolting

Flanged joints including manholes and vent opening covers shall be provided with suitable stud bolts with a removable nut on each side. Bolts and nuts shall be suitably protected against corrosion e.g. by molybdate.

Buried flanged joints shall be additionally protected in their entirety by sealing with coal tar or equivalent.

The above mentioned protection against corrosion should be preferably DME resistant.

#### 7.6.5 Gaskets/Seals

A general requirement for all gaskets and seals is that these should be gastight.

The gaskets to be used shall be suitable for DME service. Gasket materials may be selected from the following table.

Type of joint	Acceptable sealing material	Remarks
Flanged	Seal rings/gaskets made from DME-resistant material. Quality It 400 or ItC, in accordance with DIN 3754.	Thickness of gaskets not to exceed 3 mm. One ring/gasket only to be used.
Threaded	DME-resistant non-indurating sealant	Thread to be clean and free from grease. hemp or similar filaments not allowed.
Couplings with flat sealing face	Sealing made from fibre or equal DME-resistant material	Do not use more than one ring.

Note: Elastomers shall not be used as DME attacks most elastomers.

#### 7.6.6 Supports

In case supports are applied, the supporting shall be designed to avoid high local stresses in the vessel shell under the same weight conditions as specified for the foundation in § 12.1.

#### 7.6.7 Lifting ludge

On top of the vessel, two sturdy lifting lugs shall be provided which have to be symmetrically located with regard to the centre of gravity. Lifting and lowering is only allowed when the vessel is empty.

#### 7.6.8 Name plate



Each DME storage vessel has to be provided with a monel or stainless steel name plate, on which the following information shall be die-stamped:

- The registration number, allocated by the Inspection Agency;
- The designated name of the vessel;
- The name of the product;
- The volume in m<sup>3</sup>;
- The allowable (net) filling volume;
- The allowable filling rate/percentage (i.e. 86 %);
- The max. operating pressure in bar;
- The test pressure in bar;
- The minimum and maximum allowable operating temperature in °C;
- The date of the latest acceptance test and test approval stamp of the Inspection Agency.

Furthermore the manufacturer's name, address of his factory, year of fabrication and the vessels' serial number should be shown on the name plate.

The name plate shall be visible when the vessel is installed in a mound and shall be securely and irremovably attached on the vessel.

## **7.7 Welding**

### **7.7.1 General**

No production welding shall be commenced until:

- Welding procedures have been accepted by the Inspection Agency.
- Welders performance qualification tests or welders/ welder machine operator's qualifications have been approved by the Inspection Agency.

### **7.7.2 Welding procedure qualification**

Welding shall only be carried out in accordance with qualified welding procedure specifications prepared for each welding process, material and service condition, e.g. ASME Section IX, BS 4870/4871 or any other internationally accepted code.

### **7.7.3 Welders performance qualification test**

Welder and welding machine operators shall pass performance qualification tests in accordance with ASME Section IX, BS 4870/4871 or any other internationally accepted code. Existing welder qualifications are acceptable, provided the qualification is relevant to the welding to be carried-out. Welder/operator must have successfully welded the previous six months.

### **7.7.4 Welding processes**

All welding shall be carried-out in accordance with ASME code Section VIII, division 1 or the BS 5500 code.

Details of head, shell and nozzle welds shall conform to IIS/IIW-237-66 'Recommended welded connections for pressure vessels' and IIS/IIW-487-75 'Suitability grading'.

For recommended weld details reference is made to figure 7.1 'Welding details' at the end of this chapter.

## 7.8 Weld inspection

Inspection of the welds shall be carried-out prior to any painting, coating or insulation. The welded joints shall be radiographically examined as required by the ASME code, Section VIII division 1, subsection B-part UW.

All inspections shall be performed under the direction of licensed operators, qualified to the American Society of Non-destructive Testing (ASNT) Level II or equivalent. Operators shall be employed by an independent inspection company to be approved by the Inspection Agency. The results of such inspections shall be submitted to the Inspection Agency as part of the data report.

## 7.9 Hydrostatic Pressure testing

The DME storage vessel shall be subjected to a hydrostatic pressure test of 15 barg being 1.3 x the design pressure (= 11.5 barg). The pressure shall be maintained for not less than 12 hours and the test shall be carried-out either in accordance with the ASME code section VIII, div. 1 or the BS 5500 and the requirements of the inspection Agency.

## 7.10 External Coating

To protect the vessels against external corrosion these vessels are provided with a external coating. To avoid damage of this coating in case of a leakage, the external coating should be DME resistant.

*[It is assumed that the supplier of the external corrosion protection specifies the type of coating to be used, based on the requirement that the coating should be DME resistant.]*

Before the coating is applied the vessels shall be externally cleaned by shot-blasting.

Shot-blasting shall be effected to a degree of cleanliness of Sa 2.5 in accordance with Swedish Standard Specification SIS 055900 i.e. near white blast cleaning.

The surface of the vessel shall be inspected and approved prior to the application of a coating system.

Furthermore the correct appliance of the primer and the coating shall be checked in addition to an inspection of the completely applied system to ensure whether the coating complies with the requirements in every respect.

#### **7.11 Installation of vessel**

The installation of storage vessels shall be performed by a qualified contractor. Prior to covering the vessel(s) in a mound, the external coating shall be visually checked and damaged sections carefully repaired. Finally the entire coated surface shall be inspected and spark-tested (holiday detector) by the Inspection Agency

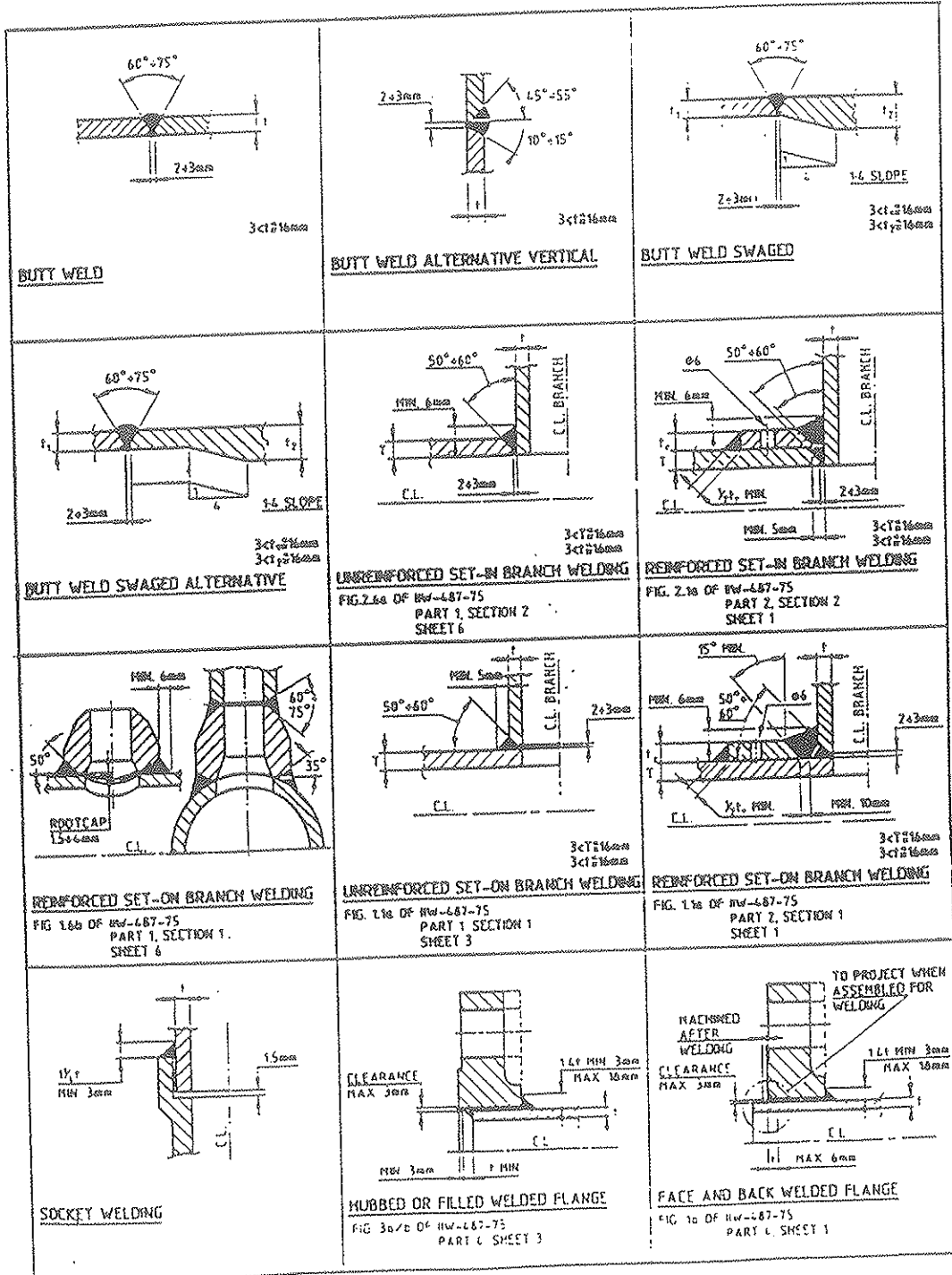

Figure 7.1 Welding details

## 8. Vessel appurtenances and DME system ancillaries

### 8.1 General

Because of the properties of DME (e.g. DME attacks most elastomers) it is only possible to equip DME storage vessels and related systems with appurtenances as described hereafter. Basically these ancillaries are DME-resistant in spite of other ancillaries and therefore no ancillaries shall be used of which make and type have not been approved by the Inspection Agency. A list of ancillaries as approved by the Dutch Stoomwezen is given in Appendix II as a guidance.

### 8.2 Valves

#### 8.2.1 General

All valves shall be made from steel, nodular cast iron or malleable cast iron, provided the material quality is suitable for DME service (DME resistant) and meets the following mechanical properties:

elongation not less than 10% (measured on  $l = 5d$ ) and with specified minimum charpy notch value of 27 joule (measured on a standard charpy notch bar) at a temperature of 253 K (-20°C) or less.

All valves having a nominal diameter of DN 50 (2") or smaller may have NPT threaded connections except valves which are installed on the nozzles of DME storage vessels i.e. on the nozzles for loading, discharge, pump by-pass and vapour return. These valves and all valves over DN 50 (2") shall be flanged.

#### 8.2.2 Valves on DME storage vessels

In and outlet nozzles of each storage vessel shall be provided with flanged hand-operated valves which may be either angle or straight through type ball, globe or gate. No valves shall be installed in piping connecting safety valves, overflow protection devices and level indicators/alarms.

#### 8.2.3 Remote controlled valves

At the shortest possible distance of the hand-operated valves, remote-controlled valves (either provided with air, gas or electrical operated actuators) shall be installed in the filling, discharge, pump by-pass and vapour return lines.

The remote-controlled valves have to be equipped with an open/closed position indicator. The valves must be 'fail safe' i.e. in case the actuating is interrupted, the valves must close within 15 seconds. No manual operation shall be possible other

than with special tools which shall not be available to the operating personnel of the DME service station.

Remote-control shall be possible from at least two different places. Push-buttons shall, as a minimum, be installed in the salesroom and at the dispensing area. Operation of these buttons shall de-energise the electrical circuit and thus cause closure of all remote-controlled valves and stoppage of the pumps. Pump start shall be impossible when the valves are closed.

The filling valve shall normally be closed. Opening of this valve shall only be possible by connection of the bonding cable of the road tank truck with the cabinet adjacent to the filling point and turning the key-operated switch in this cabinet. This also shall connect the ESD systems of truck and station and thus enable de-energising of the station's electrical circuit by operation of the truck's push-buttons as well.

At a differential pressure equal to the design pressure of the storage vessel (11.5 barg), the valves shall be easily operable and provide tight shut-off.

The remote controlled valves shall be 'fire-safe'; 'soft seated' ball valves shall meet the requirements of BS 5146, Appendix A.

Note:

A 'fire-safe' valve is a valve which, by special construction or special protection, remains tightly shut-off when exposed to fire. The manufacturer's specifications for 'fire-safe' valves shall be followed in this respect.

#### 8.2.4 Excess flow valves and check valves

Each connection of the DME storage vessel having an opening of more than 1.8 mm<sup>2</sup> (based on a maximum nominal diameter of 1.5 mm), has to be provided with either an excess flow valve or, if possible, with a check valve which shall be installed inside the storage vessel. Only the internal piping of the safety valve and the level instruments shall not be provided with these devices.

Hence check valves shall be installed for the vessel filling and the pump relief where as excess flow valves are provided on the vapour return and the discharge to the pump(s).

*[It is assumed that the supplier of excess flow valves specifies the capacity of these valves, based on the maximum operating conditions of the system.]*

#### 8.2.5 Safety valves

Each vessel shall be provided with one or more spring loaded safety valves which have to be inspected, stamped and sealed by the Inspection Agency.

These safety valves shall be suitable for DME service and be mounted on a nozzle located in a manhole or vent opening cover of the vessel; if more than one safety valve is required, these may be installed on a manifold which is connected with this nozzle.

The set pressure of the safety valves shall be equal to the design pressure of the storage vessel + 10% = 12.7 barg (11.5 + 11.5x0.1). The total relief capacity of the safety valves must at least be equal to  $Q=0.3 \times 10.66 \times A^{0.82}$ .

where  $Q$  = the capacity in  $\text{m}^3$  air/min.

Air of 288 K (15°C) at a pressure of 100 kPa.

and  $A$  = the external surface of the storage vessel concerned in  $\text{m}^2$ .

No valves, check valves, excess flow valves and the like shall be installed neither upstream nor downstream a safety valve. In case of additional safety valves being installed over and above the actual required number of safety valves, the valves may be provided with isolating valves, provided that these isolating valves are coupled in such a way that the required number of safety valves never can be shut-off.

Each safety valve shall be provided with a vertical blow-off pipe extending 2 meters above the top of mound.

Collapse of the blow-off pipe caused by excessive loads shall have no influence on the satisfactorily functioning of the safety valve concerned. Provisions shall be made to prevent rainwater to collect in the blow-off pipes (e.g. by using plastic caps).

### 8.2.6 Pressure relief valves

Piping sections in which liquid can be blocked-in between two shut-off valves must be protected against overpressure by pressure relief valves.

These pressure relief valves shall be installed 'on the line' and have sufficient blow-off capacity based on the expansion of the DME. *[It is assumed that the set pressure for these valves is related to the maximum operating pressure of the system and specified by the supplier of the safety valves.]*

Blow-down of pressure relief valves shall be allowed only at well ventilated and safe locations. Blow-down piping must not be provided with shut-off valves and shall be protected against ingress of rainwater.

### 8.3 Level indication and overflow protection

The vessel shall be provided with three level indicating and/or controlling devices:

86% ullage-valve

This valve shall be installed on a through manhole or vent opening inserted pipe which has a built-in construction leaving a passage of 1.8 mm<sup>2</sup> maximum (based on a maximum nominal diameter of 1.5 mm). The internal part of the pipe shall extend down to the maximum liquid level of the vessel (as shown on the name plate).

Note:

If the maximum (86%) level has been reached, a white cloud will become visible when opening the valve. The cloud is caused by condensing water vapour from the air. Gaseous DME escapes colourless.

#### Level indicator

A level gauge, e.g. a float-type level indicator, shall be installed of suitable construction to meet the design pressure of the vessel. If DME is blown out at that pressure, the construction shall be such that not more DME can escape than can pass a bore having a cross-sectional area of 1.8 mm<sup>2</sup> (based on a maximum nominal diameter of 1.5 mm). The use of gauge glasses standpipes and/or 'dip-tubes' is prohibited.

#### Overfill protection device

This device, an electronic measuring and control instrument, in fact serves a multitude of purposes.

Its most important function is closure of the remote-controlled valve in the filling line, when the 86% liquid level has been reached. In this respect provisions shall be made to prevent pressure surges.

In addition to overfill protection, the instrument shall:

- cause stoppage of the dispensing pumps and closure of the remote-controlled valves when a minimum liquid level in the vessel has been reached;
- provide for level indication in the weatherproof control cabinet in the vicinity of the filling point;
- provide for a pre-alarm, at the 81% liquid level in the same cabinet. This should enable the driver to stop filling in time.
- The instrument shall be fail-safe, e.g. at instrument failure filling of the vessel shall be impossible.

The device shall be suitable for the design pressure of the vessel. An instrument that complies with the German TRbP 120 regulations or with some other equivalent international standard will suffice in respect of the fail-safe requirements.

## 8.4 Pressure and temperature indicators

The vessel shall be provided with a suitable pressure gauge, which is in direct communication with the vapour space above the liquid level. A valve shall be mounted between the vessel and the pressure gauge. This pressure gauge shall preferably be combined with the pipe on which the ullage valve has been mounted.



The accuracy class of the pressure gauge shall be at least 2.5 (maximum deviation 2.5% from the full-scale end value).

If a vessel is provided with a thermometer, this instrument shall be mounted in such a way that the temperature of the liquid is measured without any part of the thermometer itself coming into contact with the liquid.

## 8.5 DME dispensing pumps

### 8.5.1 General

Pumps shall be specially designed for pumping DME (due to the poor viscosity and poor lubricity of DME) and be made either from cast steel or from cast iron (nodular or malleable) which shall meet the mechanical properties as specified for valves under § 8.2.1. They shall be provided with an overflow /relief valve to protect the pump casing from overpressure when pumping against a closed discharge. This by-pass valve shall discharge back into the DME storage vessel at a pre-determined set pressure, selected in relation with the pump curve.

The valve shall be of sufficient capacity to handle the maximum pump flow at this pressure.

The maximum differential pressure of the pump (shut-in pressure) shall be taken as 10 bar as a maximum.

The design pressure of the pump shall be at least equal to the design pressure of the piping system, which is *[hold]* barg. *[The design pressure of the piping should be related to the maximum operating pressure of the system.]*

The connection between pump and piping shall be such that unacceptable mechanical stresses can not occur, e.g. by usage of flexible steel joints, of a type which meets the approval of the Inspection Agency. Elastomers are not acceptable (as DME attacks most elastomers); the material used for this connection should be DME resistant.

Except for submerged pumps, dispensing pumps shall be placed in the open air, under a sunshade, the distance from pump centre to the horizontal projection of the vessel shall be as short as possible.

Pump and motor shall be effectively earthed.

### 8.5.2 Submerged pumps

Reference is made to figure 8.1 'Typical submerged pump arrangement'.

In case a submerged pump is applied, the following shall be adhered to in addition to the stipulations given in § 8.5.1 before.

- a) The design shall be such as to prevent imposing any unacceptable loads on the vessel. Such loads might be caused by the weight of the various parts

and/or by forces due to operation of the pump including its starting and stopping but also by vibration.

- b) It must be possible to install and remove submerged pumps at any conditions, i.e. when the storage vessel is either empty or (partly) filled.

This implies in principle that the pump is installed in a pump well which can be isolated from the vessel and whose cover flange can be removed also in case the vessel is filled. On the well itself a purge connection shall be provided for the supply of nitrogen having an opening of not more than 1.8 mm<sup>2</sup> (based on a maximum nominal diameter of 1.5 mm). The pump well shall be designed to withstand an external pressure equal to the vapour pressure of DME at 50°C (= 15 barg) and an internal pressure equal to this same pressure plus 3 bar (= 18 barg). *[It is assumed that the design of the pump is based on the maximum operating pressure of the system and that the supplier specifies the requirements for this pump.]*

The piping connections located on the well cover shall allow for easy removal of the cover plate.

- c) All piping connections on the well cover having an opening exceeding 1.8 mm<sup>2</sup> (based on a maximum nominal diameter of 1.5 mm) shall be provided with an excess flow valve inside the vessel. The excess flow valves shall have a capacity of 1.5 times of the maximum flow during normal operation; *[It is assumed that the maximum capacity of the excess flow valve for the pump-inlet is specified by the supplier and related to the maximum operating conditions of the system.]*

Only those piping connections as mentioned under e) below do not need excess flow valves.

- d) Provisions shall be made as to ensure that only a very small amount of DME can escape when dismounting a pump from a filled DME storage vessel. This means in principle, that the DME being present inside the pump and in the pump well is pushed back into the DME storage vessel by means of nitrogen (It should be noticed that CO<sub>2</sub> is highly soluble in DME and therefore CO<sub>2</sub> should not be used for purging the system).

Prior to removing the cover plate of the pump well, it must be checked whether the connection between the pump well and the storage vessel (e.g. a ball valve) is properly closed and provides a gastight shut-off.

- e) All connections should be located on the cover plate of the pump well; these connections comprise:
1. conduits for electric power;
  2. conduits for control or safety piping (e.g. hydraulic oil or nitrogen);
  3. conduits for valve stem extensions;
  4. conduits for pump shafts.

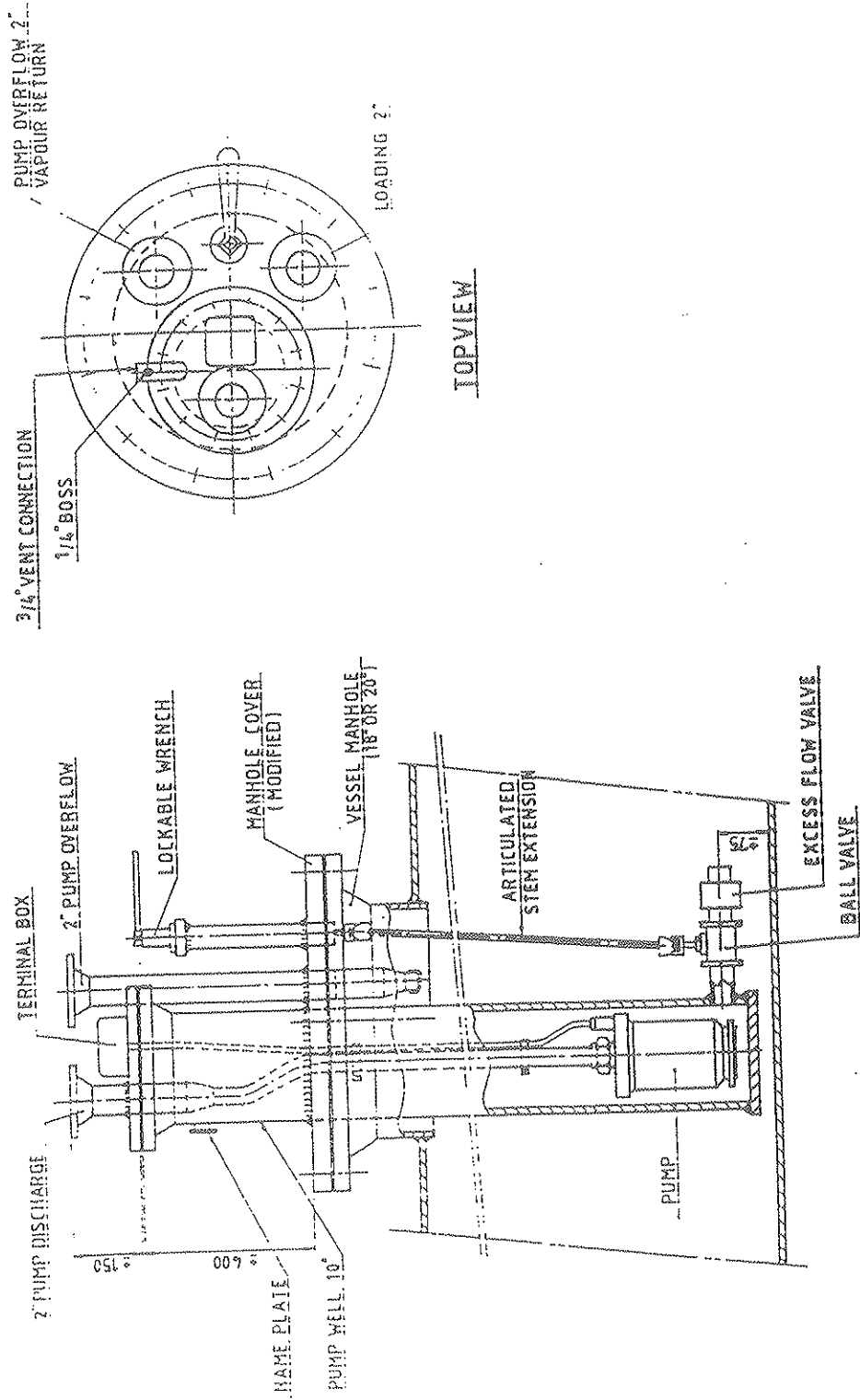

Figure 8.1 Typical submerged pump arrangement

Provisions shall be made on all conduits in such a way that in case a connection breaks, no part of it located inside the vessel can be forced through the conduit to the outside and that no DME can escape.

The conduit for the electrical power cable in the cover plate of the pump well shall be located on the inside of the well and shall not consist of a direct cable conduit with a sealing against heat.

The applied type of conduits (e.g. pins moulded in plastic plate) shall be duly approved by an inspection agency of the European Community specialised on electrical safety; the conduit shall be suitable for hazardous area's zone 0 (see § 10.1).

The conducted control tubing and safety piping connections shall be made from alloyed or carbon steel and shall be fully circumferential welded to the cover plate on both sides of the plate.

It has to be ensured that no DME can escape in case a pipe connection breaks inside the DME vessel.

- f) Control rods may only rotate.  
They have to be provided with a suitable seal to stop a possible leakage.
- g) Seals of rotating shafts shall have provisions to stop possible leakage. This may be achieved by means of the valve between the vessel and the pump well. In case two seals are installed in series, a failure of the first seal has to be indicated.
- h) The electrical installation has to conform to the CENELEC standards 50014 through 50020. All electrical equipment located on or inside the storage vessel shall be earthed. The earthed parts of the pump, motor and discharge piping have to be carefully electrically isolated from the vessel.

The entire electrical installation inside the pump well (motor, cables, conduits) shall be DME-resistant and be suitable for the following possible temperatures and pressures. 253 K (-20°C) to 323 K (+ 50°C); 15 barg (= test pressure).

## 8.6 Dispensing columns

The dispensing columns shall be specially designed for DME service and may contain either one or two filling units per column.

The enclosure of the delivery unit(s) shall be provided, both at the bottom and at the top, with two ventilation openings situated opposite each other.

The total cross-sectional area of the openings shall not be less than 50 cm<sup>2</sup>.

A push-button shall be fitted on each delivery unit and be so arranged that delivery of DME can only be achieved by pressing the push-button. This push-button may exclusively be hand-operated. Failure of pressure on the button shall stop delivery of DME automatically and instantly (dead man's button).

The hose of a delivery unit:

- a. shall not be longer than 5 m, but shall be at least 3 m;

- b. shall be resistant to DME and of an approved type;
- c. *[It is assumed that the supplier of the hose specifies the effective bursting pressure of this hose.]*
- d. shall be provided at the end with a nozzle with valve of a type approved by the Inspection Agency, which can only be opened when or after the hose is connected to the receiving fuel tank of the motor vehicle and which before or on disconnecting the hose closes automatically and instantly;
- e. shall be provided with a break-coupling of an approved type.

The liquid line for delivery of DME shall at the bottom of the dispensing unit be provided with an excess flow valve with a capacity of at most *[hold, see also § 8.2.4]* l/min.

The vapour return line of the dispensing unit shall at the bottom of the dispensing unit be provided with a check valve or an excess flow valve. If an excess flow valve is applied, the capacity shall be at most *[hold]* kg vapour per minute. *[It is assumed that the capacity of the excess flow valve (in kg vapour per minute) is specified by the supplier and related to the maximum operating conditions of the system.]*

## 8.7 Filling point assembly

To avoid delivery of the wrong product the hose connection for DME should be unique.

To supply a service station with DME, the hose of a road tank truck shall be connected to a hose coupling located at the filling nozzle of the station. This hose coupling shall be provided with a cap or blind flange by which the nozzle can be closed when not in use.

To shut-off the filling piping, immediately downstream of the hose coupling a valve shall be installed followed by a check valve to prevent back flow. At the filling nozzle an earthing lug is provided to enable bonding of the road tank truck. To enable blow-off of the hose and the piping upstream of the shut-off valve upon termination of the filling operation, a blow-off valve shall be installed, which has to be provided with a blow-off pipe extending 3 meters above grade and suitably protected against ingress of rainwater. *[It is assumed that the maximum permissible quantity of DME which may be blown-off on each occasion is specified by the supplier of the blow-off valve.]*

The entire filling nozzle assembly with the coupling, valves and earthing lug shall be suitably supported and be installed in a suitable and lockable enclosure. The hose coupling shall be installed at at least 50 cm above grade to facilitate easy handling of the hose of the tank truck.

A weatherproof control cabinet shall be installed at 5 metres distance from the filling point. This cabinet shall contain: a level indicator, a pre-alarm to indicate the 81% level, a key operated switch to actuate the remote-controlled valve in the

filling line and a receptacle for the truck's ESD-system and earthing connection cable.

The earthing lug at the filling point shall be connected with this receptacle. The connecting wiring shall be suitably protected.

Note:

A vapour-return line shall not be used for filling of the vessel.

## 9. Requirements for DME piping

In this chapter the requirements are given for the design, fabrication, inspection and testing of piping containing liquid and/or gaseous DME.

### 9.1 Design Code/Regulations

DME containing piping is subjected to the inspection and acceptance of the Inspection Agency.

The piping shall be designed, fabricated, installed, tested and inspected in accordance with ANSI/ASME B31.3: 'Chemical Plant and Petroleum refinery Piping' and as stated in these 'Regulations'.

### 9.2 Pressures

*[It is assumed that the design pressure for piping is related to the maximum operating pressure of the system and specified by the supplier.]* The pneumatic test pressure shall be equal to the design pressure.

### 9.3 Design temperature

The maximum design temperature is 323 K (+50°C).

The minimum design temperature depends on the local ambient conditions and/or the requirements of the authorities having jurisdiction. In the Netherlands the minimum design temperature is 253 K (-20°C).

### 9.4 Material

Due to the properties of DME (e.g. DME attacks most elastomers) the material used for pipe, fittings and flanges shall be low carbon steel or low-alloy steel, suitable to meet the design temperatures and made in accordance with an officially accepted material specification as described in the ISO documents 2634 and 2635.

The carbon content for all materials shall not exceed 0.23%.

Furthermore the material used should be designed to withstand the maximum possible operating pressure within the system.

#### 9.4.1 Pipe

Pipe shall be seamless and have plain ends, dimensions as per DIN 2448 or BS 3600.

For buried and above grade piping the following materials are acceptable:

- ASTM A-106 grade B, for nominal pipe size up to 1 1/2' (DN 40);
- ASTM A-106 grade B with ASTM A-520, for nom. pipe size (DN 50) or above;
- RSt 35.1 according DIN 1629, all sizes.

#### 9.4.2 Fittings

Butt-welded forged seamless steel fittings, dimensions as per BS-1640 or DIN 2615 (tees), DIN 2605 (Elbows), DIN 2616 (reducers) and DIN 2617 (caps).

Threaded forged seamless steel fittings, dimensions as per BS-3799 or DIN 2980, provided with American National Pipe Taper Thread (NPT). Acceptable material: ASTM A-234 WPS RSt 35.1 according DIN 1629.

#### 9.4.3 Flanges

Forged steel welding neck flanges made from C22 material according DIN 17200, ASTM A-105 or equivalent, having a pressure rating PN-40. Welding neck flanges as per DIN 2635, BS-4504 or equal, are acceptable. Facings should be according DIN 2513 type R13 (cover facing type V13) as described previously in § 7.6.2, however raised face flanges are also allowed (DIN 2526 form C or equal).

#### 9.4.4 Bolting

Reference is made to § 7.6.3.

#### 9.4.5 Gaskets and seals

Reference is made to § 7.6.4.

### 9.5 Design

For the DME containing piping including related piping components and ancillaries, the following shall be observed:

- The entire piping system, including the appurtenances shall, where possible, be constructed with welded joints and, where necessary, with flanged joints. The number of flanged joints shall be kept down to a minimum, while welding-neck flanges only may be applied.
- Piping and appurtenances with a nominal diameter of at most DN 50 may be joined with a tapered thread according the American National Pipe Taper



- (NPT) , but shall preferably be welded or provided with flanged joints. The use of pipe clamps is only permitted for dispensing columns.
- Buried piping shall exclusively be welded throughout.
  - Piping shall be adequately supported; special attention should be given to pipe sections with threaded connections.
  - In case the piping system and/or the storage vessel is provided with cathodic protection isolation joints shall be installed at those locations where above ground piping changes to buried installation.

Furthermore it is recommended to have the buried and the above grade piping connected with flanges. This will allow easy removal of the above grade piping to non-hazardous areas in case of repair (welding).

- The piping and appurtenances shall be effectively protected on the outside against corrosion. It is advisable to use an external coating which is DME resistant.

Buried piping shall be installed at sufficient depth to be able to withstand likely mechanical loads. The depth shall be at least 0.6 m. The piping shall be embedded by a layer of clean sand of at least 0.1 metres. Stones and other hard objects shall be removed from this sand.

- The nominal diameter of vapour lines shall be at least DN 20 (outside diameter 26.9 mm). The nominal diameter of a liquid line between the vessel and the delivery point shall be at least DN 25 (outside diameter 33.7 mm) and that of the liquid line between filling point and vessel at least DN 40 (outside diameter 48.3 mm). Lines may not be laid under buildings.  
The content of a liquid line shall be less than 0.2 m<sup>3</sup>.
- The exact location of buried DME-piping outside the boundaries of a service station shall be indicated by markers. Furthermore a continuous yellow marking tape shall be installed above the buried pipes at approximately 0.3 m below grade. The tape shall be made of a tough material to prevent tearing when dug-up.

## 9.6 Fabrication

The fabrication and installation of the DME piping and related facilities, including the installation of the storage vessels, shall be carried out by a qualified contractor. Upon termination of the installation, this qualified contractor shall provide a complete set of 'as built' installation drawings; each document stamped 'as-built', dated and duly signed.

### 9.6.1 Alignment

Before alignment and fit-up, the inside of each pipe component shall be checked for foreign material and thoroughly cleaned. Due to the fact that explosive reactions take place in the presence of oxidisers, oxygen and peroxide one should guarantee that no such substances will remain in the system after cleaning.

Pipe and fittings which have been damaged or found to have defects shall not be used. Minor surface marks may be dressed providing that the minimum wall thickness (nominal wall thickness less tolerance) is maintained.

### 9.6.2 Beveling

End profiles of pipes and fittings to be butt-welded shall be in accordance with the figure 7.1: 'Welding Details' shown in chapter 7.

Beveling is not required when a make-up length is provided.

Pipes for socket weld joints shall be cut square.

### 9.6.3 Welding spacing

For butt-welding of all piping components, pipe ends, fitting and welding neck flanges a uniform root opening of approximately 1.5 mm is required for piping up to including DN 40 and 1.5 mm - 3.0 mm for piping DN 50 and more.

## 9.7 Welding

### 9.7.1 General

No production welding shall be commenced until:

- Welding procedures and welders performance tests have been qualified in accordance with the applicable welding code and the regulations of the inspection Agency.
- Welder performance qualifications have been approved by the Inspection Agency.

### 9.7.2 Welding procedure qualification

Welding shall only be carried out in accordance with qualified welding procedure specifications prepared for each welding process, material and service condition, e.g. ASME Section IX, BS 4870/4871 or any other internationally accepted code.

### 9.7.3 Welders performance qualification test

Welders shall pass a performance qualification test in accordance with ASME Section IX, BS 4870/4871 or any other internationally accepted code. Existing welder qualifications are acceptable, provided the qualification is relevant to the

welding to be carried-out. Welders must have successfully welded the previous six months.

#### **9.7.4 Welder identification**

Each welder shall be issued with an identification card and an identification symbol. Each weld performed shall be marked with the identification symbol using chloride free paint stencilling.

#### **9.7.5 Welding processes**

All welding shall be carried-out in accordance with ANSI B 31.3 unless noted otherwise.

#### **9.8 Weld inspection**

Inspection of welds shall be carried out prior to any painting, coating or insulation and be carried-out in accordance with ASME/ANSI B 31.3 and as further specified herein. Any weld shall be inspected over its full (circumferential) length.

Radiographic examination shall be performed in accordance with section IIS/IIW-492-75 'Recommended practice for radiographic inspection of fusion-welded circumferential joints in steel pipes from 1 mm up to 50 mm wall thickness class B'.

All inspections shall be performed under the direction of licensed operators, qualified to the American Society of Non-destructive Testing (ASNT) Level II or equivalent. Operators shall be employed by an independent inspection company to be approved by the Inspection Agency. The results of such inspections shall be submitted to the Inspection Agency.

Acceptance criteria of welds shall be in accordance with ANSI B 31.3, table 327.4.1A 'Limitations on imperfections in welds'.

#### **9.9 Pressure testing**

The requirements of ANSI B 31.3 are supplemented as follows:

*[It is assumed that the supplier of equipment specifies the pneumatic pressure by means of nitrogen at which the DME piping system in its entirety shall be subjected to, based on the maximum operating pressure of the system.]* The test shall be attended by the Inspection Agency. Safety valves and pressure relief valves have to be temporarily removed prior to the testing.

After a period of approximately 10 minutes to equalise the temperature, the pressure in the system should not decrease for a continuous period of not less than 20 minutes. During the observation/test the connection with the source supplying nitrogen must be disconnected. All joints, welds and connections shall be 'swabbed' (soap tested) with a suitable leak detection solution. Test pressure shall be measured using precision pressure gauges and be recorded with a pressure recorder.

After the pressure test, the safety and pressure relief valves shall be re-installed. During start-up of the DME facilities, the connections of these valves have to be 'swabbed' as well.

All test records shall be properly noted and forwarded to the Inspection Agency.

### 9.10 Testing of the insulation joints

Insulation shall be dielectric tested by means of an ohmmeter having an internal movement of 20,000 Ohms/Volt (flanges to be tested after hydrostatic pressure testing) . The ohmmeter shall register a resistance of minimum 100 kOhm.

### 9.11 Painting and Coating

For external coating of piping it is advisable to use a coating which is DME resistant.

#### 9.11.1 External coating of buried piping

Buried piping shall be adequately protected against external corrosion by using a external coating which is DME resistant. *[It is assumed that the supplier of external corrosion protectors specifies the type of coating to be used, based on the requirement that the coating should be DME-resistant.]*

Before the coating is applied the piping shall be externally cleaned by shot-blasting or pickling.

Shot-blasting shall be effected to a degree of cleanness of Sa 2.5 in accordance with Swedish Standard Specification SIS 055900 i.e. near white blast cleaning. Pickling shall be carried-out in accordance with the American SSPC-SP8 (Steel Structure Painting Council), supplemented by the requirements as stated in § 9.12.

#### 9.11.2 Painting of above ground piping

All piping and appurtenances located above ground shall be suitably protected against corrosion by painting. The top coat of this painting shall be silver white or a similar heat reflecting colour. The hand wheels of the block valves on the filling, vapour return, dispensing and pump by-pass piping shall be painted red.

## 9.12 Pickling

### 9.12.1 General instructions

It is essential that all dust, grease and oil be removed from the pipe surface before starting the pickling process.

It is recommended, for economic reasons, also to remove rust and loose mill scale before pickling. This may be done with steel brushes.

Only clean fresh water e.g. tap-water shall be used for preparation of the pickling baths.

Throughout the pickling process, including rinsing, the pipes shall be kept separated from each other, e.g. by usage of steel chains.

To avoid carry-over of acid or water remnants from one bath to the next, the pipe material shall be drained above the first bath and be left to drip before transport to the next bath.

As soon as the contamination limits have been reached, or when the amount of sediments in the baths hampers the pickling process or contaminates the pipe material, the baths shall be refilled with fresh pickling fluids.

Pickling time shall be kept as short as possible, that is: no longer than required to produce the desired degree of cleanness. Excessive pickling times cause deterioration of the welding properties of the material.

Pickling sometimes is followed by a passivation step. This however is not essential and has been shown to have an adverse effect on the quality of coating, especially in cases where cathodic protection is applied. Therefore only pickling processes without passivation are described.

### 9.12.2 Pickling with hydrochloric acid (HCl) without passivating

The pickling bath shall be filled with hydrochloric acid with a concentration of 5 - 20% (wt) (approximately 55 - 220 gr/l).

Inhibitor shall be added to the acid to prevent undue attack on the steel as well as hydrogen brittleness. The amount of inhibitor shall be sufficient to ensure that the loss of pipe material, measured with reference plates, will not exceed 2,5 g/m<sup>2</sup> during a 30 minutes immersion time of the pipe.

The pickling bath shall normally be kept at room temperature; hardly any pickling will occur at temperatures under the 6°C, while above 30°C vapour formation takes place which causes hindrance to personnel.

The level of dissolved iron in the pickling acid must not exceed 100 g/l.

The pickling shall be considered completed when all the rust and mill scale is removed.

After pickling the pipes shall be washed and rinsed in a washing area. Because normal rinsing will not remove sediments which may still be present on the material surface it may be necessary to first spray the pipes inside and out with a high pressure water jet.

After rinsing the pipes shall be washed by dipping in a water bath for at least 5 minutes, with up and down movements, and taking them in-between at least once completely out of the water. A turbulent flow of water should be provided.

The flow in, or the periodical refreshment of, the water bath shall be such that the concentration of free acid will not exceed 0.75 g/l.

Following this washing step the pipe shall be dipped in a water bath with a temperature of at least 70°C. The pipe shall remain immersed in the hot water bath for at least 30 sec.

The periodical refreshment of the hot water bath shall be such that the concentration of free acid will not exceed 0.20 g/l.

After pickling and washing the pipes shall be dried in the open air, using the heat from the last washing process, or when quicker drying is required by ventilating with warm, oil free, dry air.

The pipes shall only be stacked when they are completely dry.

### 9.12.3 Pickling with sulphuric acid ( $H_2SO_4$ ) without passivating

The process is essentially the same as for pickling with hydrochloric acid. Some parameters differ however, as follows:

- The pickling bath shall be filled with sulphuric acid having a concentration of 5-25% (wt) , which is approximately 59-295 mg/l.
- The temperature of the bath shall preferably be kept between 50°C and 65°C.
- The periodical refreshment of the water in the first water bath shall be such that the concentration of free acid will not exceed 0.25 g/l.
- The periodical refreshment of the water in the second (hot) water bath shall be such that the concentration of free acid will not exceed 0.10 g/l.

## 10. Electrical requirements

Reference is made to figure 10.1: 'Hazardous area classification' at the end of this chapter.

### 10.1 Hazardous area classification

Areas of an installation shall be classified into danger zones, depending on the likelihood of explosive gas/air mixture occurrences. The following classification shall be used:

#### Zone 0:

An area where explosive gas/air mixture is present either continuously or during lengthy periods of time.

#### Zone 1:

An area where the presence of an explosive gas/air mixture is likely under normal operating conditions.

#### Zone 2:

An area where as explosive gas/air mixture will not likely occur or, if it should occur, this will only be for a short period of time.

#### Non-hazardous area:

An area where explosive gas/air mixtures are not expected to occur either in such quantities or during such a period, that special precautionary measures are required for electrical equipment.

Around the major equipment of the installation and the connected piping occasionally small quantities will escape. Such leakages are considered as secondary sources of hazard.

### 10.2 Area zoning

The area zoning in compliance with the above classification shall be as follows:

- Electrical equipment directly connected with the storage vessel: zone 0.
- Electrical equipment installed within 5 metres, horizontally and vertically, from the horizontal projection of the vessel with appurtenances and the filling point of the vessel: zone 2.
- Electrical equipment installed within 5 metres, horizontally and vertically from the block valve of the filling point: zone 2.
- Electrical equipment installed inside the dispensing column: zone 1.

- Electrical equipment installed horizontally within the distance formed by hose length plus 2 metres and vertically 2 metres above grade around the dispensing column and 1 metre above the dispensing column: zone 2.

Note: If the electrical installation of dispensing columns for gasoline and diesel fuel does not comply with the regulations in force for zone 2, the distance between a dispensing column for DME and those for the other fuels shall be at least 5 metres.

### 10.3 Electrical equipment

In zones 0, 1 and 2 explosion proof electrical equipment shall be applied, which complies with CENELEC standards 50014 up to 50020.

In zone 0 the equipment shall meet EEX-i-IIA-T2, in zone 1 the equipment shall meet EEX-d-IIA-T2, in zone 2 the equipment shall meet EEX-e-IIA-T2.

Pumps and motors shall be effectively earthed.

Motors shall be provided with a thermal protection device.

A contactor-starter shall be installed near all motors. The purpose and the switching positions shall be clearly indicated on or near each contactor-starter.

### 10.4 Electrical appliances

The use of transportable electric cables and transportable electrical appliances is not permitted in the danger zones, with the exception of hand-lamps with own power source and approved by the Inspection Agency.

No heated objects with a surface temperature in excess of a temperature equal to the auto-ignition temperature (zone 1 and 2) respectively 80% of the auto-ignition temperature (zone 0) or open flames may be present in these zones. The electrical installation within the explosion hazardous zone shall be capable of being switched off in all poles and phases by means of one or more circuit breakers located in a non-hazardous area.

The entire electrical installation shall comply with the installation requirements of standard IEC HD 384.

### 10.5 Illumination

Only electrical lighting is permitted. The use of sodium lighting in or near an explosion-hazardous area is strictly prohibited.

The complete installation shall be sufficiently illuminated to maintain a general overview during the dark hours. Especially at the filling point and around the dispensing area sufficient lighting shall be installed to enable safe product handling.



## 10.6 Earthing

The filling point shall be earthed, whereby the earthing resistance shall be less than *[hold]* Ohm. *[It is assumed that the supplier of the equipment specifies the required earthing resistance. The same applies for the electrical resistance between earthing lug and filling point.]*

The earthing lug shall be connected to the receptacle of the truck's bonding cable in the cabinet adjacent to the filling point, to ensure equi-potential between truck and filling point during unloading.

The filling point shall be electrically insulated from buried piping to avoid current loss of the cathodic protection. The insulating joints shall have a resistance of at least *[hold]* Ohm. *[It is assumed that the supplier of the equipment specifies the required earthing resistance.]*

The dispensing columns and dispensing pumps shall also be earthed.

## 10.7 Cathodic protection

Cathodic protection of the installation will be required unless the specific resistivity of the soil at the installation area is in excess of 100 Ohm/m. This should be established by an acknowledged expert in this field in accordance with NPR 6912 'Cathodic Protection' or a similar standard.

The need to apply cathodic protection could also arise when the sand used to cover the storage vessel has insufficient specific electrical resistivity.

It is recommended however to apply cathodic protection only where the specific resistivity of the soil would render this necessary.

If required, the cathodic protection shall constantly provide to the entire surface a potential of -850 mV or a more negative value, referred to a Cu-CuSO<sub>4</sub> reference cell. In anaerobic soils a potential of -950 mV is essential.

Measurement of the soil resistivity shall be by the soil-box method and shall not take place under exceptionally dry soil conditions. The resistivity shall be measured at least down to the lowest level of the installation, i.e. the buried piping. In cases where stray currents are likely to occur, for instance in the vicinity of high-voltage lines and of electric railways and tramways, it shall be ascertained whether these stray currents are likely to have an adverse influence on the parts of the installation to be cathodically protected. If necessary, supplementary measures shall be taken in consultation with an expert in this field.

The parts of the installation to be cathodically protected shall be electrically insulated from earthed objects. The electrical resistance of the insulators used for this purpose, measured above-ground, shall be at least 100,000 Ohms.

The measuring point of the cathodic protection in the form of a measuring post or above-ground measuring box.

The cathodic protection installation shall be checked for proper functioning before it is taken into use and subsequently at least once a year.

The findings of the inspection shall be submitted to the Inspection Agency.

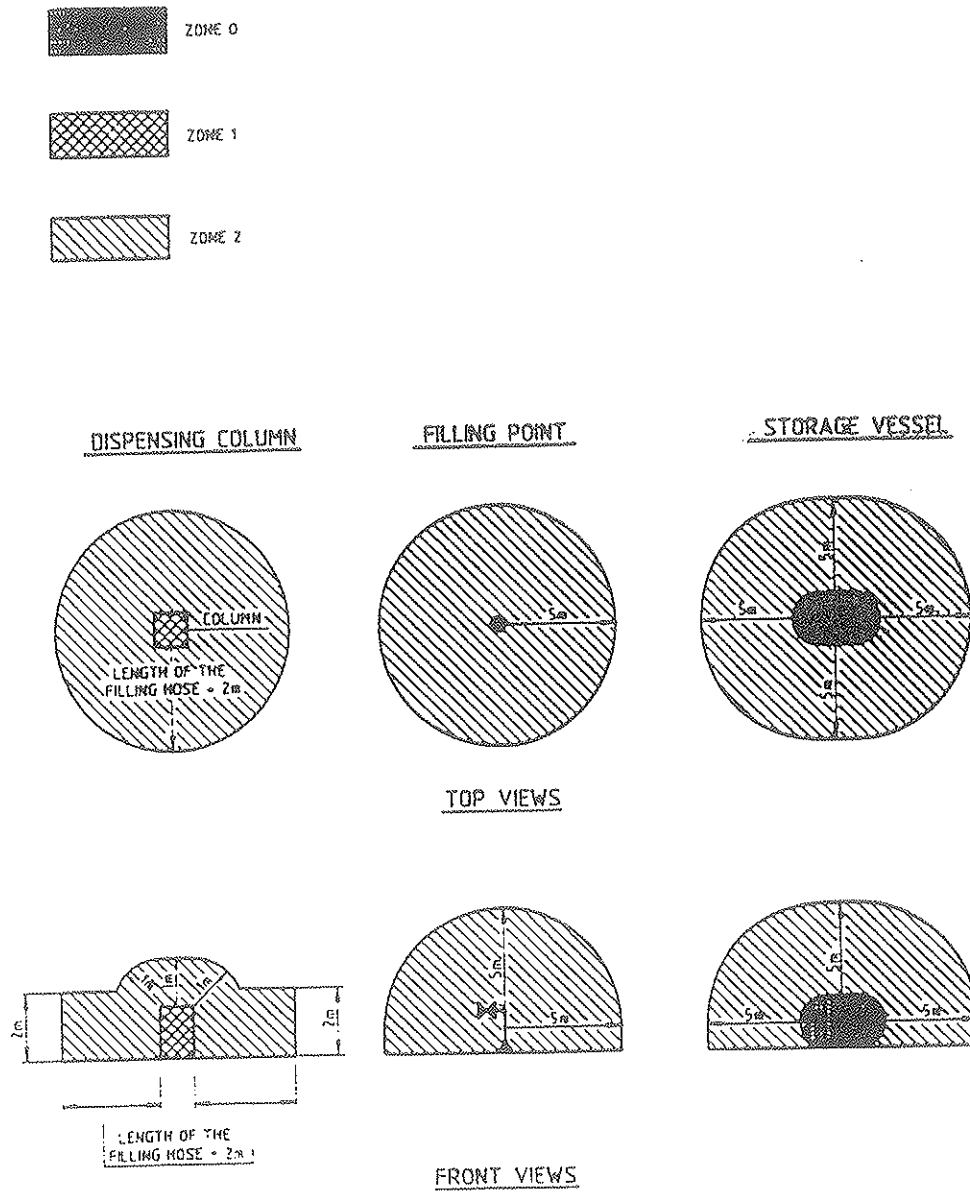

Figure 10.1 Hazardous area classification

## 11. Special safety measures

### 11.1 Safety signs

A notice reading 'NO SMOKING OR OPEN FIRE' in letters of at least 50 mm high or a corresponding safety sign in accordance with standard ISO/DIS 3864 'Safety colours and Safety signs' shall be clearly mounted on each side of the fencing around the mounded vessel as well as near the DME filling point.

Each dispensing column shall be provided with a notice in letters of at least 50 mm high reading 'STOP MOTOR, NO SMOKING OR OPEN FIRE, MAXIMUM FILLING 86%'.

### 11.2 Fire-fighting equipment

A portable powder extinguisher with a charge of 7 kg extinguishing powder shall be present at each pumping island and in the salesroom. The extinguisher shall be readily accessible and available for immediate use at all times. The extinguisher shall be examined by an expert for proper functioning at least once a year.

### 11.3 Supervised self-filling by customers

In case of supervised self-filling the following regulation shall apply:

- The supervisor shall be in a position at all times to supervise the delivery of DME from the place where the push-button control of the remote-controlled valves is installed.
- Delivery of DME shall only be possible after the supervisor has 'released' the delivery apparatus.
- During delivery of DME to the motor vehicle the supervisor shall be in the place where the push-button control of the remote-controlled valves can be operated at all times.
- A clearly legible instruction for filling the motor vehicle shall be provided on or near the dispensing column. This instruction must preferably be elucidated with illustrations.
- Provisions shall be available which, during delivery of DME, enable the supervisor, if necessary, to give verbal instructions to the person operating the delivery apparatus.

## 12. Civil work requirements

### 12.1 Foundation of storage vessel

Depending on bearing capacity of the subsoil the storage vessel may directly be placed in a prepared sand bed or be installed with saddles on a continuous, reinforced concrete foundation plate.

If placed directly on a sand bed the thickness of the artificial sand layer between the lowest point of the vessel and normal ground level shall be at least 0.3 metres. In case of a concrete foundation this layer shall be 0.2 metres minimum.

For calculations on the bearing capacity of the foundation the following factors shall be taken into account:

- weight of the empty vessel, including appurtenances, stiffeners, saddles, coating, inspection platforms and staircase;
- life load (personnel) on the platform;
- load due to snow or ice-layers (if applicable);
- weight of connected piping;
- weight of a 100% water fill (testing condition).

The foundation requirements shall be given careful attention. The concrete slab shall provide sufficient stiffeners to ensure a uniform subsoil load, as unequal settlements or sagging of the vessel by subsidence of the subsoil may lead to unacceptable material stresses, damaging of the coating and/or the loss of cathodic protection.

### 12.2 Mound

The mound of the storage vessel shall be formed of clean sand from which sharp objects and stones of more than 3 mm diameter have been removed. To protect the sand mound from erosion, sliding off or from being damaged in any other way the mound shall be covered with a layer of tiles. Clay, silt or peat containing filling shall not be used as vegetation could grow, the roots of which might damage the coating of the vessel. For the same reason all vegetation in the direct vicinity of the mound shall be removed.

The minimum soil cover of the mound shall be as follows:

- 0.2 or 0.3 metres sand layer underneath the vessel, depending on the foundation (see § 12.1 above).
- 0.3 metres on top of the vessel.
- 0.2 metres on top of the manhole.
- 0.3 metres on the sides, the sides shall have a regular slope, except for the side where the pumps are installed. On this side a straight vertical wall may be constructed.

The bottom layer shall be stabilised by tampering and water flooding.

### 12.3 Underground installed vessel

A buried storage vessel shall be fully embedded in 0.3 metres of clean sand from which sharp objects and stones of more than 3 mm have been removed. The covering soil has to be protected from erosion or any other damage by a layer of tiles. Clay, silt or peat containing filling shall not be used as vegetation could grow, whose roots might damage the coating of the vessel. For the same reason all vegetation in the direct vicinity of the underground storage vessel(s) shall be removed.

The minimum requirements for the embedding of an underground storage vessel are as follows:

- 0.2 or 0.3 metres sand layer underneath the vessel, depending on the foundation (see 12.1 above);  
This bottom layer shall be stabilised by tampering and water flooding.
- 0.3 metres on top of the vessel as a minimum; the thickness actually is dictated by the requirement of having a layer of:
  - 0.2 metres on top of the manhole covers.
  - 0.3 metres around the vessel.

The vessel has to be protected against buoyancy and setting in such a way that the vessel coating cannot be damaged and the cathodic protection system - if present - will remain undisturbed.

In case a concrete slab is placed on top of the vessel to prevent buoyancy, the thickness of this plate may be deducted from the required thickness of the sand cover (i.e. 0.3 metres) but the remaining sand layer shall not be less than 0.2 metres). The top of the concrete slab may be installed at grade; thus no tiles will be required.

### 12.4 Drainage

The drainage facilities of the service station and surrounding area shall be such that even during heavy rainfall the water table in the mound will not raise above grade.

### 12.5 Fire-resistance

The salesroom and other buildings related to a DME service station shall be designed in accordance with the building codes and standards and the requirements of the authorities having jurisdiction. It should be noticed that the fire-resistance properties of the materials to be used may have an impact on the lay-out and the safety of the DME service station in its entirety.

The fire-resistance of materials shall be determined in accordance with ISO-specifications 834, 3008 and 3009.

Walls, floors and ceilings required to meet certain fire-resistance requirements shall not be effected by any connection to other constructional parts, passages for cables, conduits and ducts.

Doors and hatches in walls, floors and ceilings, which are required to meet fire-resistance requirements, shall possess fireproof qualities corresponding to those of the wall, floor or ceiling in which they are installed, or else have no adverse effect on the said qualities. Doors and hatches having a fireproofing function shall, except for the instant passage of persons or goods, be closed and only be kept in an open position by means of special devices which close these doors and hatches automatically in a situation requiring their fire-resistance performance.

Doors and hatches in escape ways shall have provisions to open them from the inside.

Ventilation and air-heating ducts, as well as ventilation openings or ventilation gratings shall, at the point where they pass through walls, floors or ceilings, which are required to meet fire-resistance requirements, be provided with an effective fire valve, unless such ducts are designed to meet the fire proof requirements. The fire valve shall close automatically as soon as a situation arises in which this is required to meet these requirements.

Windows and light openings in walls and ceilings, which are required to meet fire-resistance requirements shall be secured and meet fire-resistance requirements corresponding to those imposed for the wall or the ceiling in which they are installed.

The following average data may give an indication about fire resistance of various construction materials:

Minerals in principle do not burn. The fire-resistance of walls etc. made from concrete, brick, glass wool, gypsum etc. depends largely on their thickness.

A 110 mm brick wall has a fire-resistance of about 150 min, a 125 mm thick gypsum sandwich type wall filled with glass wool has a fire-resistance of about 80 minutes. A 200 mm thick wall made of air expanded concrete blocks may even have a fire-resistance of 6 hours.

Standard window glass panes have hardly any fire-resistance since they burst; wired glass and the like give much better resistance values.

A standard wooden door, sandwich construction, inside chipboard, will have a fire resistance of approximately 30 minutes.

## 13. Inspection and approvals

### 13.1 General procedure

The Inspection Agency will carry-out the inspection in the following sequence:

- Design supervision.  
Fabrication of vessels and piping shall not start unless the design has been approved.
- Fabrication supervision.  
Supervision of manufacturer's construction activities.
- Testing and acceptance of individual components of a DME system.  
Vessels, appurtenances, piping components and ancillaries must be approved/accepted prior to being incorporated in the DME system.
- Final inspection of the DME system at the service station. The DME system in its entirety shall be inspected and tested.

The various inspection activities are described hereinafter in more detail.

### 13.2 DME storage vessels

Each DME storage vessel shall be subjected to inspection and approval of the Inspection Agency prior to being installed. In this respect the activities of the Inspection Agency will comprise:

- design supervision;
- fabrication supervision;
- shop testing/vessel acceptance.

#### 13.2.1 Design supervision

The approval for construction will be given upon review and approval of:

- vessel calculations and construction drawings;
- specifications of intended construction materials;
- welding procedures.

#### 13.2.2 Fabrication supervision

During the fabrication stage, the Inspection Agency will:

- qualify the welders;
- check workmanship and fabrication procedures;
- check whether all construction materials conform to the certificates;
- review results of non-destructive testing.



### 13.2.3 Shop testing/vessel acceptance

Upon completion of the construction the Inspection Agency will inspect and test the vessel which will include:

- an internal and external inspection of the vessel including a check of the overall dimensions, flange ratings and sizes, position of nozzles and type of vessel appurtenances;
- attending the hydrostatic pressure testing (see § 7.9);
- inspection of the external coating (see paragraph 7.10);
- acceptance of the fabrication report comprising all material certificates, test records, vessel data sheet and construction drawings.

Upon acceptance of the vessel, the Inspection Agency shall stamp the name plate accordingly.

### 13.3 Vessel appurtenances and DME system ancillaries

Vessel appurtenances and DME system ancillaries shall be of a make and type as approved by the Inspection Agency. General requirements applicable for the various appurtenances and system components are given in chapter 8; as a guide for the procedures to be followed to obtain such an approval, reference is made to M0806/83-12 of the 'Rules for Pressure Vessels as given in Appendix II'.

Once the make and type of a particular appurtenance have been approved by the Inspection Agency upon receipt of the manufacturer's test and material certificates.

### 13.4 DME piping systems

The inspection and acceptance of the piping will be performed by the Inspection Agency at site (i.e. the DME service station concerned) or in the shop.

Prior to starting the construction the Inspection Agency shall have given:

- approval on welding procedures;
- approval on welder qualifications;
- approval on materials for pipe, fittings, flanges etc.;
- approval on the P&ID's (piping and instrument diagrams) showing the DME related systems in their entirety with all components, safety devices and instruments;
- approval on the specific appurtenances and ancillaries intended to be installed (check on make and type);
- approval on the construction drawings.

During fabrication the Inspection Agency will supervise the construction activities.

### 13.5 Final acceptance of the DME station facilities

The Inspection Agency will officially accept the DME system of a service station upon satisfactory inspection in accordance with appendix XIII: 'Checklists for inspection of DME Service Stations'. The principal will then officially be notified that the DME facilities are released for operation.

#### 14. Qualification of contractors for work on DME installations

In order to ensure the safe construction and operation of DME installations the Inspection Agency requires contracting companies who want to be active in this field to prove their capabilities.

A contractor is only eligible for qualification if, to the satisfaction of the Inspection Agency, the contractor meets certain requirements.

These requirements are defined in Appendix III, the 'Regulation concerning the qualification of contractors for the construction, maintenance, repair, inspection and testing of DME-installations'.

This 'Regulation for qualification' sets forth the requirements regarding quality of work and company organisation which shall be met by the Contractor. It also describes the procedure to be followed for qualification and rules regarding the duration of validity of qualification.

Contractors which comply with the above mentioned regulation will be issued a Certificate of Registration as DME-contractor, permitting them to perform activities in this field.

## 15. List of literature

- [1] Regulations for LPG Service Stations and Road Tank Trucks in The Netherlands  
COMPRIMO report, September 1987
- [2] Thermodynamic and Physical Property Data  
Carl L. Yaws  
ISBN 0-88415-031-3
- [3] Methods for the Calculation of Physical Effects ('Yellow Book')  
CPR 14E, third edition 1997
- [4] LPG distribution depots (Butane, propane and mixtures hereof)  
CPR8-3E, first edition 1991





*TNO-report*  
TNO-MEP – R 99/29011

## Regulations for DME Service Stations and Road Tank Trucks in the Netherlands

TNO Institute of  
Environmental Sciences,  
Energy Research and  
Process Innovation

### Section 2: Regulations for the management and operation of DME service stations

Laan van Westenenk 501  
P.O. Box 342  
7300 AH Apeldoorn  
The Netherlands

Date  
10-02-99

Phone +31 55 - 549 34 93  
Fax +31 55 - 541 98 37

Author(s)  
S.J. Elbers

Order no.

This draft report is supplied for internal use only and the results may not be made known to third parties as having been produced by TNO. In this respect attention is drawn to article 8 (liability) and article 4 (rights concerning results) of the Standard Conditions for Research instructions given to TNO.

Keywords

Intended for

All rights reserved.  
No part of this publication may be reproduced and/or published by print, photoprint, microfilm or any other means without the previous written consent of TNO.

In case this report was drafted on instructions, the rights and obligations of contracting parties are subject to either the Standard Conditions for Research Instructions given to TNO, or the relevant agreement concluded between the contracting parties. Submitting the report for inspection to parties who have a direct interest is permitted.

© 1998 TNO

The Quality System of the TNO Institute of Environmental Sciences, Energy Research and Process Innovation has been certified in accordance with ISO 9001.

The TNO Institute of Environmental Sciences, Energy Research and Process Innovation is a recognised contract research institute for industry and government with expertise in sustainable development and environmentally oriented process innovation.

Netherlands Organisation for  
Applied Scientific Research (TNO)

The Standard Conditions for Research Instructions given to TNO, as filed at the Registry of the District Court and the Chamber of Commerce in The Hague, shall apply to all instructions given to TNO.

## Section 2: Regulations for the management and operation of DME service stations

### Table of contents

1. INTRODUCTION .....	4
2. SCOPE.....	5
3. DEFINITION OF TERMS .....	6
4. PRODUCT INFORMATION.....	8
4.1 DME.....	8
4.2 PROPERTIES OF DME.....	8
5. MANAGEMENT OF THE INSTALLATION.....	10
5.1 OPERATING STAFF.....	10
5.2 INSTALLATION BOOK.....	10
5.3 EMERGENCY PLAN .....	10
5.4 MEDICAL FIRST AID.....	11
5.5 ADR PRODUCT CARD.....	11
5.6 FIRE-FIGHTING EQUIPMENT .....	11
5.7 STORAGE VESSEL AREA.....	11
5.8 DAMAGE BY PLANTATION .....	11
5.9 POSITION OF REMOTE-CONTROLLED VALVES.....	11
5.10 DEGASSING AND INGASSING OF STORAGE VESSEL .....	12
5.11 INSTALLATION/DISMOUNTING OF SUBMERGED PUMPS.....	12
5.12 SAFE HANDLING OF DME.....	12
5.13 REPORTING OF INCIDENTS .....	12
6. DME-DELIVERIES TO CUSTOMERS .....	13
6.1 RESTRICTIONS CONCERNING THE DELIVERY.....	13
6.2 SAFETY MEASURES .....	13
6.3 SUPERVISED SELF-FILLING BY CUSTOMERS .....	14
6.4 ILLUMINATION .....	14
7. DME STORAGE VESSEL FILLING .....	15
7.1 ROAD TANK TRUCK.....	15
7.2 DRIVER OF THE TRUCK.....	15
7.3 TRUCK ENGINE.....	15
7.4 ARTIFICIAL LIGHTING AND OPEN FIRE.....	16
7.5 CONNECTION OF STATION'S AND TRUCK'S CONTROL SYSTEMS.....	16
7.6 FILLING HOSES .....	16
7.7 FILLING PROCEDURE .....	16
8. MAINTENANCE, REPAIRS AND INSPECTIONS.....	18
8.1 GENERAL.....	18



8.2 MAINTENANCE AND REPAIRS .....	18
8.3 MODIFICATIONS .....	18
8.4 WORK PERMIT.....	18
8.5 PERIODIC INSPECTIONS .....	19
9. LIST OF LITERATURE .....	20

### Applicable Appendices

III	Regulations concerning the qualification of contractors for the construction, maintenance, repair, inspection and testing of DME-installations
IV	Procedure for the commissioning of new or degassed DME-installations
V	Procedure for depressurizing and degassing the DME-installation
VI	Procedure for the installation/dismounting of submerged pumps
VII	ADR-product card (transport emergency group card)
VIII	Medical first aid
IX	Example of emergency plan
X	Installation book for DME service stations
XIII	Checklists for inspection of DME service stations

## 1. Introduction

This sections forms part of the 'Regulations for DME Service Stations and Road Tank Trucks'.

It provides the regulations for the management and operation of a DME service station with DME storage of either the 'mounded' type, i.e. storage vessels installed above grade covered with a mound of sand, or DME storage vessels installed underground.

The 'Regulations concerning the management and operation of DME Service Stations' given in this document, are based on existing requirements for LPG service stations [1] and made specific for DME where necessary.

The application of the 'Regulations' as mentioned in this section will contribute to the safe operation of DME stations and to the prevention of hazards while handling this product.

While every effort has been made to ensure the accuracy and reliability of the data contained in these regulations, neither TNO nor the authors shall be held responsible or liable in any way for loss or damage resulting from their use or from any violation of state or international regulations with which they may conflict.

The regulations also cannot be deemed to contain all conditions that must be necessarily be fulfilled for safe construction and usage. The liability remains with principals, manufacturers and the management for the installation.

## 2. Scope

This section covers the requirements related to the management and operation of DME service stations, comprising facilities for DME supply to the station, DME product storage and the delivery of DME to motorcars.

The section provides guidance for a good management of such an installation and for the safe handling of DME.

Requirement concerning the operating staff as well as concerning the management of a station are given in addition to regulations for the delivery of DME to customers, filling of DME storage vessels and maintenance, repair and inspection.

In this section reference is made to applicable appendices of the 'Regulations' which contain information regarding: regulations for the qualification as DME contractor, the contents of an 'Installation Book', an example of an 'Emergency plan', first aid measures, procedures for depressurisation and degassing of DME installations and for the commissioning of new or degasses installations, as well as checklists for inspection of DME service stations.

Aspects of design and construction of DME service stations are covered in section 1, 'Regulations for the design and construction of DME service stations', which also forms part of the 'Regulations for DME Service Stations and Road Tank Trucks'.

### 3. Definition of terms

For the purpose of these Regulations the following definitions shall hold:

*ADR*

European Agreement concerning the international Carriage of Dangerous Goods by Road.

*BLEVE*

'Boiling Liquid Expanding Vapour Explosion'

An explosion caused by the sudden formation and subsequent ignition of large quantities of DME vapours, normally due to rupture of a storage vessel.

*Contractor (qualified)*

Contractor is a company which carries-out activities in the field of construction, maintenance, repair, inspection and testing of DME installations. A qualified contractor has acquired a valid certificate of registration from the Inspection Agency.

*Degassing*

Degassing is the procedure by which the gas concentration in a storage vessel and/or related piping system is safely reduced and then maintained at a level which is not higher than 10% of the lower explosion limit.

*DME*

Di-methyl ether, which is used as fuel for motorcars

*DME delivery column*

An apparatus designed for deliveries of DME into DME tanks of motorcars, also called dispenser column.

*DME road tank truck*

A truck, equipped with a storage vessel and appurtenances, especially designed for the transport of DME by road.

*DME service station*

An establishment containing facilities where DME is stored and dispensed to motorcars.

*Filling point*

The connection point for the hose of the tank truck. At this point DME is transferred from the road tank truck to the installation. The tank truck is unloaded, the storage vessel filled.

*Ingassing*

The procedure by which DME is transferred into a gasfree DME storage vessel and /or piping system, thereby increasing the gas concentration up to a level well exceeding the upper explosion limit.

*Inspection Agency*

An institution, governmental or private, authorised to perform inspection work on a DME installation or part there-of. This includes all matters related to the engineering, fabrication, inspection and testing of such installations.

*Mounded storage vessel*

A DME storage vessel, installed above grade completely covered by a mound made of sand covered with tiles.

*Principal*

The company which initiates and ultimately pays for the design and construction of a DME service station and hence will be involved in the control of the quality of the station's facilities and the services rendered.

*'Regulations'*

The Regulations for DME Service Stations and Road Tank trucks.

*Underground storage vessel*

A DME storage vessel, installed below grade, completely covered by soil.

## 4. Product information

### 4.1 DME

Dimethyl ether is produced from 'syngas' by means of a catalytic process. Syngas is a mixture of hydrogen, carbon monoxide and carbon dioxide which is often used by the industry as an intermediate step for the production of many chemicals and also for power generation. Syngas can be made from a variety of feedstock such as natural gas and coal, but also from renewable feedstock like wood.

### 4.2 Properties of DME

DME is in the vapour phase at atmospheric pressure and normal ambient temperatures: the atmospheric boiling point of DME is  $-24.8\text{ }^{\circ}\text{C}$ . Liquefaction of DME at ambient temperatures requires pressurisation. Typically, the vapour pressure of DME is approximately 5.3 bar at  $20\text{ }^{\circ}\text{C}$ .

If the pressure is reduced to atmospheric, e.g. by leakage, DME evaporates quickly. When DME evaporates it expands to about 350 times its original liquid volume and, as gaseous DME is approximately 1.8 times as heavy as air, spreads out at ground level accumulating in low places as cellars or sewers.

During evaporation the temperature of DME reduces. When mixed with air this causes condensation of the water vapours in the air and a visible cloud of the gas/air mixture is formed.

If, however, DME in the gaseous state is released into the atmosphere, this gas remains invisible.

DME becomes explosive when mixed with air. A mixture of containing between approximately 3.4 vol% and 18 vol% of DME in air is within the explosion limits and is highly flammable. A small spark or the presence of static electricity could already cause an explosion.

DME does not have to be classified as a dangerous toxic substance. However, DME produces an anaesthetic or narcotic effect with inhalation of vapours. Concentration of 5 - 20 % by volume can cause irritation, incoordination, shortness of breath, drowsiness, intoxication, blurring of vision, headaches, dizziness, excitation, and unconsciousness. These appear to be short-term effects caused by short-term exposure.

DME in higher concentrations, in excess of 20 %, can increase the risk of cardiac irregularities and possible cardiac arrest. In high concentrations DME replaces breathing air and acts as a simple asphyxiant. This is the result of the displacement and lack of oxygen.

Although DME has a slight ethereal odour, an odorant will need to be added to aid in detection of leaks.

The detection of leaks should be by the use a suitable gas detector and NEVER WITH A NAKED FLAME.

Liquid DME is lighter than water and therefore water, if present in a road tank truck or storage vessel will collect at the bottom of the vessel. Besides, DME is soluble in water through which part of the DME will be within the water phase.

DME is in pure form not corrosive to steel, which is used in the construction of road tank truck and storage vessels and piping, but contamination in the DME attack most elastomers.

Furthermore, DME is a poor conductor and has a poor fuel viscosity and lubricity through which the design of the appurtenances such as pumps, meters etc. is affected.

## 5. Management of the installation

### 5.1 Operating staff

A DME service station shall only be managed by appropriately instructed persons.

If the installation is open for delivery of DME, an adult (at least 18 years old) person who is responsible for the supervision, shall be present at the installation and shall have at his immediate disposal a telephone connected to the public telephone system.

The operating personnel shall have sufficient expertise, both as regards the safety regulations to be observed under normal operating conditions and in regard to the necessary actions to be taken in case of gas leakage or fire.

The personnel shall be fully conversant with the 'Emergency plans'(see also § 5.3). A copy of this plan shall be readily available in the salesroom.

The personnel shall be trained in the usage of the fire-fighting equipment and in the application of medical first aid. (See also § 5.4 and § 5.6).

In the salesroom, an installation book shall be present. The operating personnel shall be familiar with its contents.

### 5.2 Installation book

The management and the operating staff of a DME service station shall observe the instructions and procedures as laid down in the 'Installation book', the contents of which shall comply with Appendix X.

The management shall ensure that the installation book is always kept up-to-date.

### 5.3 Emergency plan

An emergency plan to control the hazards of serious DME leakages and/or fire must have been made in consultation with the local authorities, e.g. the fire-brigade.

This plan shall contain: instructions for emergency shut-down of the installation, warnings to customers and other people in the installation surroundings, calls for assistance, usage of fire-fighting equipment.

An example of an emergency plan is given in Appendix IX. The plan procedure shall be tested at least once a year.



#### **5.4 Medical first aid**

A first aid kit and protective clothing (at least: eye goggles and leather or thick textile gloves with arms protection) shall be present in the salesroom. First aid instructions are given in Appendix VIII.

#### **5.5 ADR product card**

An ADR product card (Transport emergency group card) shall be available at the installation. An example of such a card is given in Appendix VII.

#### **5.6 Fire-fighting equipment**

One portable powder extinguisher with a charge of 7 kg extinguishing powder shall be present near each pumping island and in the salesroom. The extinguishers shall be readily accessible and available for immediate use at all times. The extinguishers shall be examined by an expert for proper functioning at least once a year.

#### **5.7 Storage vessel area**

The doors in the fencing around the storage vessels shall be easily accessible at any time. These doors shall always be kept closed and locked except when maintenance or repair work is carried out inside the fencing. The area inside the fencing shall not be used for the storage of any goods other than the storage of DME in the storage vessels.

#### **5.8 Damage by plantation**

In the direct vicinity of a vessel no plantation shall be allowed of which the roots can penetrate into the protective coating of the vessel, unless the vessel has been specially protected against ingrowing roots. The application of plastic foil is prohibited.

#### **5.9 Position of remote-controlled valves**

When the DME service station is not opened for delivery of DME to customers, the remote-controlled valves shall be closed and the dispensing column locked.

The remote-controlled valves in the filling lines shall always be kept closed unless filling of the storage vessel necessitates their opening.

## 5.10 Degassing and ingassing of storage vessel

No work involving the use of fire or work which may cause leakages or fire shall be performed on vessel, piping and appurtenances unless the installation has been degassed and depressurized. This shall be done in accordance with the procedure of Appendix V.

Commissioning of a gas-free vessel shall be done in accordance with the procedure of Appendix IV. Both activities shall only be performed by a qualified contractor.

## 5.11 Installation/dismounting of submerged pumps

In case of maintenance or replacement of submerged pumps installed in underground DME storage vessels, the work to be performed shall be done in strict accordance with the procedure of Appendix VI.

## 5.12 Safe handling of DME

DME SHALL BE HANDLED WITH CARE !

While working at a DME-installation the following basic rules shall be adhered to:

- Never blow-off more gaseous DME into the open air than strictly necessary.
- Prevent liquid DME from flowing out in the open air.
- Do not open a DME storage vessel before the vessel is completely depressurized and degassed. Do not enter the vessel before the vessel is aerated!
- Measure the oxygen content first. If nitrogen or another suitable inert gas has been used for degassing the same applies: do not enter before aeration ! Do not use CO<sub>2</sub> for degassing due to the fact that CO<sub>2</sub> is completely soluble in DME. Furthermore, do not use any substance that will form an explosive reaction with DME, such as oxidisers, oxygen and peroxide.
- Never work in a cloud of DME. Gas will penetrate into the clothing and, when ignited, would cause terrible burns. Exposure to skin or eyes can also cause irritation or dermatitis. If exposure is to the eyes it causes inflammation of the ocular mucous membranes. In addition contact with the vaporising liquid can cause frost bite.

## 5.13 Reporting of incidents

In case of an unexpected event (break-down of a system, collision etc.) whereby an inflammable quantity of DME has escaped or may escape from the station facilities, measures shall be taken immediately to limit the effects of this event. Also the authorities concerned shall be notified at once.

## 6. DME-deliveries to customers

### 6.1 Restrictions concerning the delivery

DME deliveries shall only take place via the dispensing columns and only to:

- Fuel tanks, exclusively intended for the storage of DME and specially designed for driving motor vehicles and attached to these vehicles;
- Exchange tanks specially designed for this purpose with a capacity of at most 150 litres and intended for driving lifting and transport equipment. Delivery into these exchange reservoirs shall only take place in the open air;
- The tank of the DME tank truck when the installation is being emptied.

DME deliveries to customers either direct from the road tank truck or from skid-mounted vessels temporarily placed at the site are prohibited.

The maximum filling rate of fuel and exchange tanks is 80 %. This value is based on the following equation:

$$M_{\max} = 0.95 * \rho_{\text{liquid, } 50^{\circ}\text{C}}$$

where  $M_{\max}$  = the maximum allowable mass per litre of contents, in kg/l  
and  $\rho$  = the density of the liquid at 50°C, in kg/m<sup>3</sup>.

For DME the maximum allowable mass per litre of contents is equal to 0.58kg/l [2]. Based on a contents of 20 m<sup>3</sup> the maximum mass of filling is: 0.58\*1000\*20 = 11,600 kg.

The density of liquid DME at a temperature of -20°C is equal to 720.3 kg/m<sup>3</sup> [3]. By using this data, the volume which is taken up with liquid DME can be calculated as: 11600/720.3 = 16.1 m<sup>3</sup>. Taking into account the total capacity of the vessel of 20 m<sup>3</sup>, the maximum filling degree can be calculated as: (16.1 / 20)\*100 = 80%.

#### Filling of gas bottles:

Filling gas bottles with DME is prohibited. A clearly legible notice in lettering at least 50 mm high and reading: 'FILLING GAS BOTTLES WITH DME IS STRICTLY PROHIBITED' shall be present at the dispensing area.

### 6.2 Safety measures

The engine of the vehicle to which delivery is taking place shall be switched off before connecting the dispensing hose and may not be started again until after this hose has been uncoupled and replaced to the column.

Delivery of DME is prohibited if smoking is going on or any fire or artificial lighting, other than insulated artificial lighting, is present within a distance of 5 m.

### 6.3 Supervised self-filling by customers

In case of supervised self-filling the following regulation shall apply:

- The supervisor shall be in a position at all times to supervise the delivery of DME from the places where the push-button control of the remote-controlled valves is installed.
- Delivery of DME shall only be possible after the supervisor has 'released' the delivery apparatus.
- During delivery of DME to the motor vehicle the supervisor shall be in the place where the push-button control of the remote-controlled valves can be operated at all times.
- A clearly legible instruction for filling the motor vehicle shall be provided on or near the delivery column. This instruction must preferably be elucidated with illustrations.

Provisions shall be available which, during delivery of DME, enable the supervisor, if necessary, to give verbal instructions to the person operating the delivery apparatus.

### 6.4 Illumination

The complete installation shall be sufficiently illuminated to maintain a general overview during the dark hours. Especially at the filling point and around the dispensing area sufficient lighting shall be installed to enable safe product handling.

Only electrical lighting is permitted. The use of sodium lighting in or near an explosion-hazardous area is strictly prohibited.

## **7. DME storage vessel filling**

### **7.1 Road tank truck**

The storage vessel shall only be filled from a road tank truck which meets the requirements as stated in the 'Regulations for design and construction of DME Road Tank Trucks'.

The volume of the truck's vessel shall be at least 20 m<sup>3</sup> (water contents).

The tank truck shall be located in a safe area at a maximum of 5 metres from the filling point and in such a manner that the vehicle can be driven off easily and quickly.

The unloading of a DME tank truck may not take place simultaneously with the unloading of another tank truck for motor fuels, unless the DME tank truck is situated at a distance of more than 25 metres from this tank truck.

### **7.2 Driver of the truck**

Filling of the vessel shall be done by the driver of the tank truck. The driver may not proceed to fill the vessel until after he has received permission to do so from the person in charge of the installation or his authorised representative.

Before proceeding to fill the vessel the driver shall make certain that the situation in the vicinity is sufficiently safe.

The driver shall then determine the quantity of DME still present in the storage vessel, whereafter he shall establish the volume of the load. Throughout the filling period the driver shall stay with the tank truck and ascertain whether the maximum admissible filling level (86%) is not exceeded. Vessel filling shall be terminated before this level is reached.

The truck driver shall be in the possession of a licence for transport and handling of dangerous goods.

### **7.3 Truck engine**

The engine of the tank truck may not be running during coupling or uncoupling of the filling hose. Running of the engine is permitted if this is required for vessel filling but only after the hose has been connected.

#### 7.4 Artificial lighting and open fire

Filling of the vessel is prohibited, if someone is smoking or any fire or artificial lighting, other than insulated artificial lighting, is present.

#### 7.5 Connection of station's and truck's control systems

A connection cable, for the dual purpose of discharging static electricity and connection of the truck's emergency shut-down (ESD) system with that of the service station, shall be connected between the cabinet adjacent to the filling point and the tank truck prior to connection of the hose required for filling.

This cable may not be disconnected until after the filling operation has been completed and the hose is uncoupled.

Note:

It shall be impossible to fill the vessel without first having made this connection. Reference is made in this respect to section 3 of the 'Regulations'.

#### 7.6 Filling hoses

The hoses used for vessel filling shall invariably first be visually checked before use. Damaged hoses shall be removed for repair or replacement. Only the hoses of the tank truck shall be used for vessel filling. These hoses shall have a length of maximum 7.5 metres and shall not be rolled out more than strictly necessary.

Both during coupling and uncoupling of the hoses and during filling the hoses may not come into contact with sharp parts likely to cause damage. When coupling or uncoupling the hoses the occurrence of sparks must be avoided, for instance by using non-sparking tools.

#### 7.7 Filling procedure

The discharge of DME into the storage vessel of an DME service station shall be carried out by the driver of the tank truck in accordance with the following procedure.

The driver shall:

- ensure that the area is safe for unloading;
- position the vehicle at the designated area of the service station, facing the direction of departure;
- stop the engine, apply the handbrake and place wheel chocks in position if the ground is sloping;
- inform the attendant of the service station that he/she intends unloading;
- read off the contents gauge of the storage vessel,

- visually inspect the vessel connections for tightness and establish the maximum filling load;
- open the metering cabinet of his truck, which energises the drive-off alarm;
- connect the connection cable with the filling point of the service station. This provides earthing and ensures the connection of the truck's emergency shutdown (ESD) system with that of the service station;
- carefully remove the protection caps or flanges from the hose connections and connect the hose to the filling point, using only spark-free tools if any;
- inspect the filling point connection for tightness; apply the switch key of the switch at the filling point in order to open the remote-controlled filling valve of the service station;
- start the engine of the truck, open the push-button operated remote-controlled bottom-valves of the truck's vessel and the hand-operated block valves and start the pump;
- remain in close proximity of the truck throughout the unloading operation and check on the level gauge installed near the filling point whether the maximum filling level of the storage vessel is not exceeded;
- stop the pump timely before the maximum filling level would be reached. A pre-alarm with a setting of approximately 5 vol% below the maximum level should provide an early warning to the driver;
- close the filling valves of the tank truck including the remote-controlled valves and stop the engine;
- apply the switch key at the filling point to close the remote-controlled filling valve of the station, close the hand-operated filling valve at the filling point and vent the small amounts of DME enclosed between the connections;
- disconnect the hose, replace the protective cap or flange on the hose-end and filling point and put the hose back on the hosereel;
- disconnect the cable which provided the earthing and coupling of ESD-systems;
- establish and put on record the exact amount loaded and close the cabinet. This de-activates the drive-off alarm, and on some trucks also the remote-controlled valves and the pump switch;
- visually inspect the storage vessel, filling point and tank truck for leak-tightness and inform the attendant of the station that the filling operation is ended;
- remove the wheel chocks (if used) , start the engine and drive-off.

## 8. Maintenance, repairs and inspections

### 8.1 General

The facilities of a DME-service station shall be maintained in a good state at all times.

### 8.2 Maintenance and repairs

Maintenance work and repairs on the DME containing parts of the installation shall be carried-out by a qualified contractor (reference is made to Appendix III). Repairs to components of the DME containing parts of the installation shall at all times be discussed with and approved by the Inspection Agency prior to commencing the work.

The repair shall be recorded in the Installation logbook. Replacement of appurtenances by identical parts does not require reporting, but shall also be recorded in the Installation logbook.

No work involving the use of fire or work which may cause leakage or fire shall be performed on vessel, piping and appurtenances unless the installation (part) has been depressurized in accordance with the procedure given in Appendix V.

### 8.3 Modifications

Modifications shall prior to the execution of the work be discussed with and approved by the Inspection Agency and be carried-out by a qualified contractor. The modifications shall be incorporated in the installation schemes and drawings.

### 8.4 Work permit

Prior to starting modification, repair, maintenance or cleaning work which requires depressurization or degassing, the work shall be properly planned and appropriate measures must have been taken in consultation with the persons involved in carrying out the work.

*It should be specified which amount of DME should be involved in the event that (part of) the installation has to be depressurized or degassed, before the measures concerned must be laid down in writing and signed by or on behalf of the principal and by the contractor representative (work permit).*

The work-permit shall:



- be dated with a maximum daily extension of five consecutive days. Each Monday a new work-permit shall be extended to include other work if during execution of the originally envisaged and permitted activities this proves necessary.
- be renewed if the work has been interrupted for special reasons.
- be renewed if other persons than those to whom the work-permit was granted are to execute the work.
- be handed-over to the installation manager when the work is finished.
- be filed in the installation logbook and be presented on request of personnel involved or the relevant authorities.

Note:

The installation manager shall ensure that, when the work is finished, the contractor representative declares in writing that the work has been performed in accordance with the 'Regulations'. This statement shall be filed in the installation logbook.

## 8.5 Periodic Inspections

Reference is made to Appendix XIII: 'Checklists for inspection of DME service station', in which the exact extent of the various periodic inspections, by qualified contractors and by the Inspection Agency, are listed.

In addition to these inspections regular inspection by the station's operating staff is mandatory: the station's facilities shall be inspected regularly in accordance with the instructions as laid down in the Installation logbook.

Inspections of the DME facilities by a qualified contractor shall take place at half-yearly intervals. These inspections shall include testing or renewal of the dispensing hoses.

The Inspection Agency shall inspect the cathodic protection system at least once a year.

The installation in its entirety shall be inspected by the Inspection Agency at least once every six years. These inspections shall include the coating of the storage vessel(s). In case of modifications, major repairs or after the occurrence of an earthquake the installation shall be re-inspected as well by the Inspection Agency.

The results of each inspection shall be recorded in the installation logbook.

## 9. List of literature

- [1] Regulations for LPG Service Stations and Road Tank Trucks in The Netherlands  
COMPRIMO report, September 1987
- [2] European Agreement concerning the international Carriage of Dangerous Goods by Road (ADR)  
1997 edition, Annex B
- [3] Thermodynamic and Physical Property Data  
Carl L. Yaws  
ISBN 0-88415-031-3

*TNO-report*  
TNO-MEP -- R 98/29011

## Regulations for DME Service Stations and Road Tank Trucks in the Netherlands

TNO Institute of  
Environmental Sciences,  
Energy Research and  
Process Innovation

### Section 3: Regulations for the design and construction of DME road tank trucks

Laan van Westenenk 501  
P.O. Box 342  
7300 AH Apeldoorn  
The Netherlands

Phone +31 55 - 549 34 93  
Fax +31 55 - 541 98 37

Date  
10-02-99

Author(s)  
S.J. Elbers

Order no.

This draft report is supplied for internal use only and the results may not be made known to third parties as having been produced by TNO.

In this respect attention is drawn to article 8 (liability) and article 4 (rights concerning results) of the Standard Conditions for Research instructions given to TNO.

Keywords

Intended for

All rights reserved.

No part of this publication may be reproduced and/or published by print, photoprint, microfilm or any other means without the previous written consent of TNO.

In case this report was drafted on instructions, the rights and obligations of contracting parties are subject to either the Standard Conditions for Research Instructions given to TNO, or the relevant agreement concluded between the contracting parties.

Submitting the report for inspection to parties who have a direct interest is permitted.

© 1998 TNO

The Quality System of the TNO Institute of Environmental Sciences, Energy Research and Process Innovation has been certified in accordance with ISO 9001.

The TNO Institute of Environmental Sciences, Energy Research and Process Innovation is a recognised contract research institute for industry and government with expertise in sustainable development and environmentally oriented process innovation.

Netherlands Organisation for  
Applied Scientific Research (TNO)

The Standard Conditions for Research Instructions given to TNO, as filed at the Registry of the District Court and the Chamber of Commerce in The Hague, shall apply to all instructions given to TNO.

## Section 3: Regulations for the design and construction of DME road tank trucks

### Table of contents

1. INTRODUCTION .....	6
2. SCOPE.....	7
3. REFERENCES .....	8
3.1 GENERAL .....	8
3.2 MECHANICAL STANDARDS.....	8
3.3 VARIOUS STANDARDS:.....	10
3.4 ELECTRICAL STANDARDS.....	10
4. DEFINITION OF TERMS .....	12
5. DESCRIPTION OF A DME ROAD TANK TRUCK .....	14
5.1 GENERAL .....	14
5.2 THE VESSEL .....	14
5.3 UNLOADING AND FILLING SYSTEMS.....	14
5.4 OPERATION CONTROL AND SAFETY SYSTEMS.....	15
5.5 ADDITIONAL SAFETY MEASURES .....	17
6. GENERAL DESIGN REQUIREMENTS.....	23
6.1 GOVERNING REGULATIONS .....	23
6.2 DESIGN FLUID .....	23
6.3 CARRYING VEHICLE .....	23
6.4 MOUNTING OR VESSEL AND PIPING ON THE CHASSIS.....	23
6.5 FIRE-FIGHTING APPLIANCES.....	24
6.6 LABELLING AND MARKING .....	24
7. SAFETY SYSTEMS.....	25
7.1 EMERGENCY SHUT-DOWN SYSTEMS.....	25
7.2 THERMAL PNEUMATIC PLASTIC TUBE.....	25
7.3 BONDING .....	25
7.4 DRIVE-OFF ALARM .....	25
8. REQUIREMENTS FOR DME VESSELS .....	27
8.1 DESIGN CODES AND REGULATIONS.....	27
8.2 VESSEL VOLUME .....	27
8.3 DEGREE OF FILLING.....	27
8.4 DESIGN PRESSURE.....	27
8.5 HYDRAULIC TESTPRESSURE .....	28
8.6 DESIGN TEMPERATURES.....	28
8.7 MATERIALS .....	28
8.8 VESSEL CONNECTIONS .....	29

8.8.1	General	29
8.8.2	Required connections	29
8.8.3	Location	29
8.8.4	Size	30
8.9	CONSTRUCTION	30
8.9.1	Manhole	30
8.9.2	Flanged connections	30
8.9.3	Threaded connections	30
8.9.4	Bolting	31
8.9.5	Gaskets and seals	31
8.10	NAME PLATE	31
8.11	SUPPORTING	31
8.12	ANTI-SLOSHING BAFFLES (SURGE PLATES)	32
8.13	HYDROSTATIC PRESSURE TEST	32
8.14	EXTERNAL COATING	32
9.	VESSEL APPURTENANCES	33
9.1	GENERAL	33
9.2	VALVES	33
9.2.1	General	33
9.2.2	Bottom valves	33
9.2.3	Excess flow valves and checkvalves	34
9.2.4	Hand-operated block valves	34
9.2.5	Safety valves	34
9.2.6	Pressure relief valves	35
9.2.7	Blow-off valves	35
9.3	LIQUID LEVEL INDICATOR AND FILLING GRADE CONTROL	35
9.3.1	Ullage valve assembly	35
9.3.2	Level indicator	36
9.3.3	Overfill alarm	36
9.4	PRESSURE AND TEMPERATURE INDICATORS	36
9.5	FILTERS	36
9.6	TRANSFER PUMPS	36
9.7	FLOW METERS	37
9.8	FLEXIBLE JOINTS	37
9.9	HOSES AND HOSE REELS	37
9.9.1	Hose reel assemblies	37
9.9.2	Hoses	37
9.9.3	Hose couplings and adapters	38
10.	REQUIREMENTS FOR DME PIPING	39
10.1	DESIGN CODES AND REGULATIONS	39
10.2	DESIGN AND TEST PRESSURES	39
10.3	DESIGN TEMPERATURES	39
10.4	DESIGN	39
10.5	MATERIALS	40
10.5.1	Pipe	40
10.5.2	Fittings	40
10.5.3	Flanges	40

10.5.4 Bolting and threaded connections .....	40
10.5.5 Gaskets and seals.....	41
10.6 FABRICATION.....	41
10.7 WELDING .....	41
10.7.1 General.....	41
10.7.2 Welding procedure qualification .....	41
10.7.3 Welders performance qualification test.....	41
10.7.4 Welder identification .....	41
10.7.5 Welding processes .....	41
10.7.6 Weld inspection.....	42
10.8 PRESSURE TESTING .....	42
10.8.1 Hydrostatic Pressure testing (strength test).....	42
10.8.2 Pneumatic tightness test .....	42
10.8.3 Test Records .....	42
10.9 EXTERNAL CORROSION PROTECTION.....	43
<b>11. ELECTRICAL REQUIREMENTS .....</b>	<b>44</b>
11.1 HAZARDOUS AREA CLASSIFICATION.....	44
11.2 AREA ZONING .....	44
11.3 ELECTRICAL EQUIPMENT.....	44
11.4 ELECTRICAL APPLIANCES .....	45
11.5 EARTHING.....	45
<b>12. INSPECTIONS AND APPROVALS .....</b>	<b>46</b>
12.1 FIRST INSPECTION .....	46
12.1.1 DME vessel.....	46
12.1.2 Vessel appurtenances and DME system ancillaries .....	46
12.1.3 DME piping systems .....	47
12.2 FINAL ACCEPTANCE OF THE DME INSTALLATION OF THE TRUCK.....	48
<b>13. QUALIFICATION OF CONTRACTORS FOR WORK ON DME INSTALLATIONS .....</b>	<b>49</b>
<b>14. LIST OF LITERATURE .....</b>	<b>50</b>

### Applicable appendices

- Appendix I Product information;
- Appendix II Appurtenances for DME, list of accepted makes
- Appendix III Regulations concerning the qualification of contractors for the construction, maintenance, repair, inspection and testing of DME
- Appendix XII Applicable articles of the ADR concerning DME road tank trucks installations

## 1. Introduction

This section forms part of the 'Regulations for DME Service Stations and Road Tank Trucks'.

It provides the regulations for the design and construction of DME road tank trucks.

In recent years studies have been performed for the introduction of DME as a car fuel. Part of these studies are related to the evaluation of the risk when handling DME. As a result of these studies a number of measures have been and are still being taken to improve the safety of DME handling in all its aspects.

The 'Regulations for the design and Construction of DME service stations' given in this section are based on the existing requirements for LPG Road tank trucks [1] and made specific for DME where necessary.

The application of the 'Regulations' as mentioned in this section will contribute to the safe construction of DME facilities on road tank trucks and to the prevention of hazards while handling this product.

While every effort has been made to ensure the accuracy and reliability of the data contained in these regulations, neither TNO nor the authors shall be held responsible or liable in any way for loss or damage resulting from their use or from any violation of state or international regulations with which they may conflict.

The regulations also cannot be deemed to contain all conditions that must be necessarily be fulfilled for safe construction and usage. The liability remains with principals, manufacturers and the management for the installation.



## 2. Scope

This section covers the requirements related to the design, fabrication, installation, testing and inspection of DME related equipment and facilities to be installed on road tank trucks which are to be used for the supply of DME to DME service stations.

Specific requirements for the carrier itself have only been dealt with in so far as these are directly related to the safety of the DME facilities on the truck.

In this section reference is made to appendices I, II and III of the 'Regulations' which contain information regarding DME properties, accepted makes of DME appurtenances and regulations for the qualification as a DME contractor.

The specific requirements set forth in the ADR - The European Agreement concerning the International Carriage of Dangerous Goods by Road - shall be considered to form part of these regulations. The applicable articles of the ADR have been listed in Appendix XI.

Aspects of the management of road tank trucks and of the transport and handling of DME by road tank trucks including drivers's instructions, are covered in section 4 'Regulations for the management and operation of DME Road Tank Trucks', which also forms part of the 'Regulations for DME Service Stations and Road Tank Trucks'.

### 3. REFERENCES

In these Regulations reference is made to the following publications:

Note:

The latest issue of each publication should be used together with any amendments/supplements/revisions to such publications.

#### 3.1 General

ADR-European Agreement concerning the International Carriage of Dangerous Goods by Road (Dutch version).

Published by: SDU publishers, The Hague, 1997

#### 3.2 Mechanical Standards

ANSI Standards:

ANSI B 1.5               Screw threads  
ANSI B16.5              pipe flanges and flanged fittings

Published by: American National Standards Institute Inc.  
1430 Broadway, New York, New York 10018.

API recommended-practice

API RP 520              Design and installation of pressure relieving systems in refineries - part I design

Published by: American Petroleum Institute 1801 K. Street N.W.  
Washington, D.C. 20006

ASME Boiler and Pressure Vessel Code:

Section VIII, div. I    Pressure Vessels  
Section IX              Welding and brazing qualifications

ASHE Code for Pressure Piping B-31:

ANSI/ASME B-1.3      Chemical plant and petroleum refinery piping

Published by: The American Society of Mechanical Engineers  
345 East 47th Street  
New York, New York 10017

ASTM Codes:

ASTM A 105 Specification for forgings, carbon steel, for piping components  
 ASTM A 520 Specification for supplementary requirements for seamless and electric resistance welded carbon steel tubular goods

Published by: American Society for Testing and Materials 1916 Race Street  
 Philadelphia, PA  
 19103

BS Codes:

BS 1640 Steel butt-welding fittings for the petroleum industry  
 BS 3600 Specification for dimensions and masses per unit length of welded and seamless steel pipes and tubes for pressure purposes  
 BS 3799 Steel pipe fittings, screwed and socket-welding for the petroleum industry  
 BS 4504 Flanges and Bolting for pipes, valves and fittings. Metric series  
 BS 5500 Unfired fusion welded pressure vessels

Published by: British Standards Institution  
 2 Park Street  
 London W1A 2BS

CEOC Codes:

R49/CEOC/83 Approval of manufacturers of fittings and flanges  
 R25/CEOC/79 Principles for the approval of austenitic rolled and forged steels  
 R26/CEOC/79 Principles for approving materials for components which require inspection by a CEOC-Organisation  
 R29/CEOC/83 Test plan for the certification of rolled and forged steels including fine-grain structural steels with ferritic-pearlitic structure (normalised), bainitic structure and/or tempered structure (air or liquid quenched as well as age hardened)

Published by: CEOC (Colloque Européen des Organismes de Contrôle):  
 Secrétariat Général  
 Groupements des APAVE  
 102, Rue des Poissonniers 75018 Paris

DIN Codes:

DIN 1629 sh. 3 Seamless pipe from carbon steel  
 DIN 2448 Plain and seamless steel pipe  
 DIN 2513 Flanges, facings, male and female  
 DIN 2526 Flanges, types of facings  
 DIN 2605 Butt-welded elbows  
 DIN 2615 Steel butt-welded fittings, tees  
 DIN 2616 Steel butt-welded fittings, reducers  
 DIN 2517 Steel butt-welded fittings, caps  
 DIN 2634 Welded neck flanges NP 25  
 DIN 2635 Welded neck flanges NP 40  
 DIN 3754 Compressed asbestos fibre

Published by: Deutsches Institut für Normung  
Beuth Verlag GmbH  
Burggrafenstrasse 4-10  
1000 Berlin 30

IIS/IIW codes:

IIS/IIW-492-75 Recommended practice for radiographic inspection of fusion welded circumferential joints in steel pipes from 1 mm up to 50 mm wall thickness class B

Published by: International Institute of Welding  
54 Princess Gate, Exhibition Road  
London SW7

ISO Specifications:

ISO 6708 Pipe components. Definition of nominal size

ISO 7268 Pipe components. Definition of nominal pressure

Published by: International Standardisation Organisation  
Geneva, Switzerland

### 3.3 Various Standards:

SIS 055900 Pictorial surface preparation standards for painting steel surfaces

Published by: Swedish Standard Commission  
Tegnergatan 11  
Box 3295  
S-10366 Stockholm

TRbF Technische Regeln für Brennbare Flüssigkeiten (Technical Rules for Flammable liquids),

Published by: Deutscher Fachschriften - Verlag  
Wiesbaden

### 3.4 Electrical Standards

Electrical apparatus for Potentially explosive Atmospheres

EN 50.014 General requirements;

EN 50.015 Oil immersion 'o';  
EN 50.016 Pressurised apparatus 'p';  
EN 50.017 Powder filling 'q';  
EN 50.018 Flameproof enclosures 'd';  
EN 50.019 Increased safety 'e';  
EN 50.020 Intrinsic safety 'i'

BD 384 Electrical installations of buildings

Published by: CENELEC, European Committee for Electrotechnical  
Standardisation, General Secretariat  
2, Rue Brederode, B-1000  
Brussels, Belgium

#### 4. Definition of terms

For the purpose of these Regulations the following definitions shall hold:

*ADR*

European Agreement concerning the international Carriage of Dangerous Goods by Road.

*Ancillaries*

The term ancillaries covers all appurtenances and system components required for the safe operation of DME storage vessels and piping systems. Ancillaries comprise items such as valves, relief valves, pumps, pressure gauges, metering equipment, controls, etc.

*BLEVE*

‘Boiling Liquid Expanding Vapour Explosion’

An explosion caused by the sudden formation and subsequent ignition of large quantities of DME vapours, normally due to rupture of a storage vessel.

*Check valve*

A check valve is a device which prevents the medium in a piping system from flowing back.

*Contractor (qualified)*

Contractor is a company which carries-out activities in the field of construction, maintenance, repair, inspection and testing of DME installations. A qualified contractor has acquired a valid certificate of registration from the Inspection Agency.

*Degassing*

Degassing is the procedure by which the gas concentration in a storage vessel and/or related piping system is safely reduced and then maintained at a level which is not higher than 10% of the lower explosion limit.

*DME*

Di-methyl ether, which is used as fuel for motorcars

*DME road tank truck*

A truck, equipped with a storage vessel and appurtenances, especially designed for the transport of DME by road.

*DME service station*

An establishment containing facilities where DME is stored and dispensed to motorcars.

*Excess flow valve*

A shut-off device, which provides a nearly complete automatic shut-off in case of an excessive flow rate e.g. line break.

*Ingassing*

The procedure by which DME is transferred into a gasfree DME storage vessel and /or piping system, thereby increasing the gas concentration up to a level well exceeding the upper explosion limit.

*Inspection Agency*

An institution, governmental or private, authorised to perform inspection work on a DME installation or part there-of. This includes all matters related to the engineering, fabrication, inspection and testing of such installations.

*Nominal diameter DN*

A numeric indication for the size of piping systems according to standard ISO-6708.

*Nominal pressure PN*

A numeric indication for the pressure according to standard ISO-7268.

*Pressure*

The unit kPa and bar indicate absolute pressure; the expression 'gauge pressure' means absolute pressure minus atmospheric pressure.

*Pressure relief valve*

An automatic pressure-relieving valve actuated by over pressure in a liquid-filled system, caused e.g. by thermal expansion of the fluid.

*'Regulations'*

The Regulations for DME Service Stations and Road Tank trucks.

*Safety valve*

An automatic pressure-relieving valve actuated if the static pressure upstream of the valve exceeds a pre-set pressure and characterised by rapid full opening or pop action. It is used for gas or vapour service.

*Stoomwezen*

The Dutch governmental inspection authority 'Dienst voor het Stoomwezen' is referred to as 'Stoomwezen'. 'Stoomwezen' is the authority having jurisdiction in all matters related to the engineering, fabrication, testing, inspection, and installation of (pressure) vessels, piping and piping systems.

*Storage Capacity*

The net volumetric contents of a vessel when filled with water up to the maximum allowable level for DME storage.

*Vessel volume*

The volumetric contents of a vessel when completely filled with water.

## 5. Description of a DME Road tank truck

Reference is made to figure 5.1: 'Typical scheme of DME facilities on a road tank truck' with list of appurtenances; to figure 5.2: 'Typical DME road tank truck'; to figure 5.3: 'Simplified control system' and to figure 5.4: 'Excess flow type bottom valve', shown at the end of this chapter.

### 5.1 General

A DME road tank truck is a vehicle especially designed for the transport of DME, comprising:

- the vehicle itself;
- the DME related equipment.

The vehicle may be either an automobile manufacturers' standard trailer-tractor combination or a truck chassis. These standard type vehicles are adapted for carrying the DME related equipment. For instance, the combustion air inlet for the engine will be located at least 1.50 m above grade, the chassis prepared for mounting the vessel and equipment and the electrical system modified.

The DME related equipment, permanently mounted on the carrying vehicle, comprises the following:

- the pressure vessel for transport of DME;
- equipment for filling and unloading of the vessel and related piping;
- operation control and safety systems.

### 5.2 The vessel

The tank of a DME road tank truck must be suitable to transport the liquid under pressure. This pressure vessel, which is permanently fixed to the vehicle's chassis, is provided with a manhole, nozzles for filling and unloading, safety relief valves, temperature and level indicators and pressure gauges.

A sunshield will reduce the raise of temperature - and consequently a raise of pressure - during transport. Internal anti-sloshing baffles are provided to reduce the liquid forces being transmitted to the chassis when the vehicle brakes or accelerates.

### 5.3 Unloading and filling systems

Road tank trucks must be equipped with means for independent unloading DME into the storage facilities of DME service stations and, in addition, with means for filling their own vessel, i.e. with discharge hoses, a pump, related piping and other ancillaries.



The unloading and filling equipment and piping is located in protecting cabinets, fitted at the side of the chassis.

The unloading and filling connections of the vessel are protected with remote-controlled, air or hydraulically actuated shut-off valves, called bottom valves, which are situated inside the vessel and close automatically within 15 seconds in case of emergency.

#### Unloading system

Upon opening of the outlet bottom valve, the DME is filtered prior to entering a motor driven DME transfer pump. In case of a hydraulic motor the hydraulic pump for this motor is driven by the truck's engine. The transfer pump is protected against overpressure by a relief valve installed in a relief/overflow line leading back to the vessel. This vessel connection is also protected by a "bottom valve".

The DME liquid pumped to the service station is measured by a flowmeter; a vapour separator is installed upstream of the meter (the flowmeter itself may be provided with a ticket printer for recording and billing purposes). In the pump discharge line, various system components are installed, such as a differential pressure valve, excess flow valves and shut-off valves.

The unloading piping terminates in a hose reel with a flexible hose, which is provided with a manual shut-off valve and a hose coupling. A blow-down valve may be installed to release blocked-in DME after completion of the filling. For unloading purposes other than to a DME service station, a second unloading connection may be provided.

#### Vessel filling system

The filling piping may be combined with the unloading piping provided that the common vessel connection is protected by a quick closing internal bottom valve.

Usually, the depots/refineries where the DME road tank trucks are filled, have facilities which include filling pumps. If necessary, however, the filling can also be achieved by means of the road tank trucks' own transfer pump. In that case, the pump will discharge in a by-pass line leading back to the vessel. Prior to entering the vessel, the by-pass line is combined with the pump relief/overflow piping.

### **5.4 Operation control and safety systems**

Road tank trucks are provided with electrical circuits for the vehicle itself as well as for the operation control of the DME facilities and the safety systems. The battery master switch for activation of all circuits must be placed as close to the battery as possible.

This switch should be operable from inside the cab as well as from outside the vehicle at a readily accessible place.

The electrical system for the DME facilities is provided with an emergency shut-down system, which interrupts the unloading activities when manually or automatically activated: all bottom valves will then close automatically.

Supplementing the electrical control and the ESD systems, the tank trucks are provided with auxiliary systems such as:

- compressed air system, used to operate air operated bottom valves and to provide the thermal pneumatic fire detection tube with air;
- hydraulic system, if applicable, used to drive the DME transfer pump and hydraulically operated bottom valves.

#### Bottom valves

The filling and discharge connections of the vessel are provided with air or hydraulically operated "bottom valves", mounted inside the vessel.

These valves are of special design and often combine:

- the functions of a remote-controlled shut-off valve and of a check valve when installed in a filling line;
- the functions of a remote-controlled shut-off valve and of an excess flow valve when installed in a discharge line.

An example of the working of such valves is given in figure 5.4, at the end of this chapter.

When the electrical circuits are activated and the cabinet which houses the piping and equipment is opened, the DME loading and unloading facilities (i.e. the bottom valves, metering and the pump) are operable as the control and emergency shut-down systems are energised.

The fluid (preferably air) supply to the valve actuators is inside the cabinet executed by means of thermal tubing. When this tubing melts the valves close automatically.

#### ESD system

Push-buttons installed in the electrical system, located adjacent to the cabinet, at the left-hand front side and at the right-hand rear side of the vessel, provide for possible manual interruption of the electrical supply, with resulting closure of the bottom valves and stopping of the pump.

A thermal plastic pneumatic tube is installed horizontally around the vessel. Release of air pressure in this tube causes automatic interruption of the electrical supply with the same effects.

During the filling operation of the station's storage vessel, the ESD systems of truck and station are interconnected. If the truck's ESD system is operated, either by means of one of the push-buttons or by melting of the pneumatic tubing, this also results in de-energising the station's facilities and closure of the remote-controlled shut-off valves of this service station.

Note:

Instead of an electrical ESD system, a pneumatic ESD system could also be applied.

### **5.5 Additional safety measures**

In order to minimise the damaging effects of collisions, the filling and discharge equipment should be placed in a cabinet located between the axles and within the horizontal projection of the vessel.

The sides of the vessel and related piping and equipment should be protected by horizontal bars, where-as a sturdy bumper installed at the rear of the vehicle should protect the vessel and its appurtenances at the back.

The truck should also be provided with an audible and visual alarm system, which should be activated if the truck is driving off and the handbrake is loosened while the cabinet is still open.

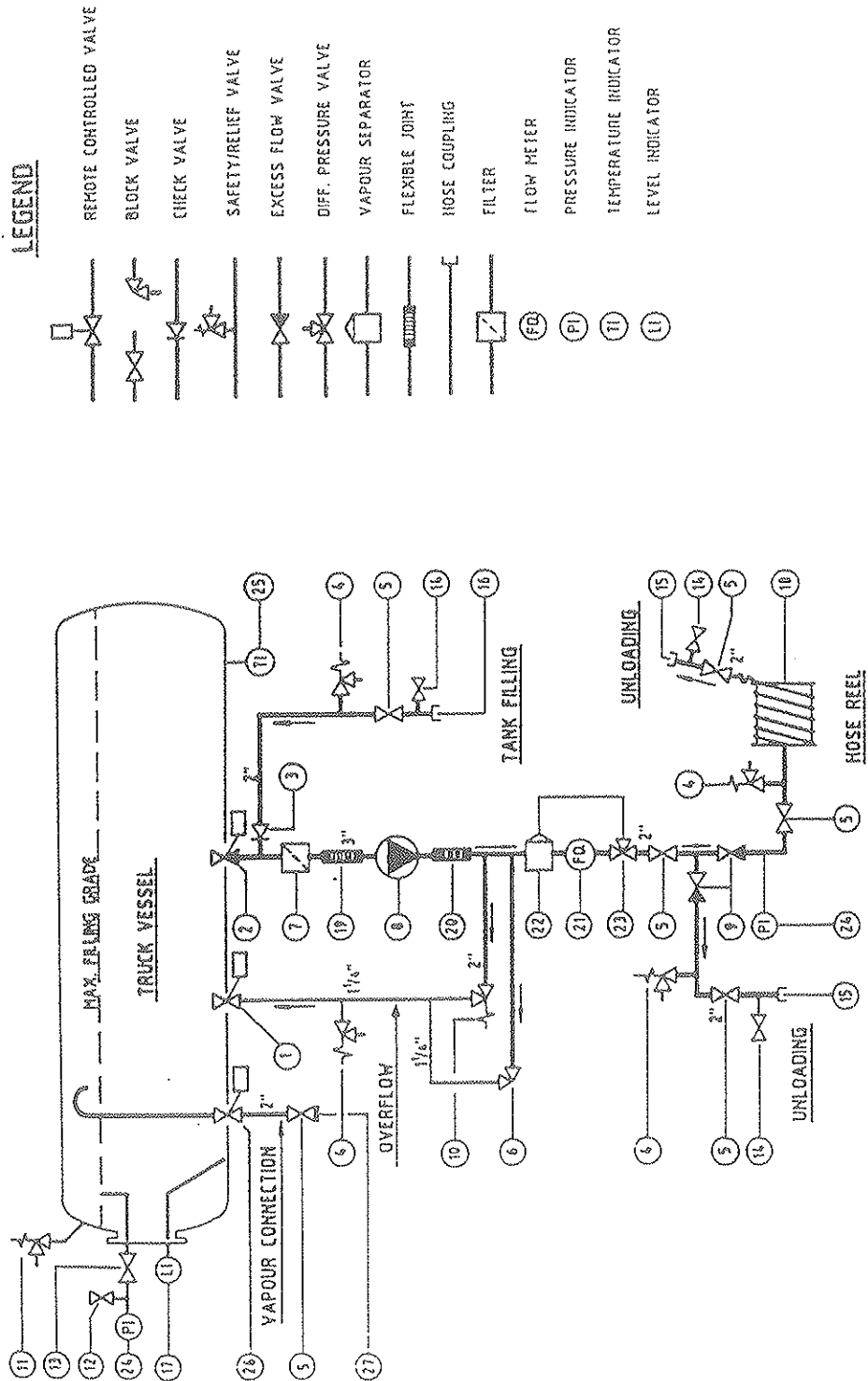

Figure 5.1 Typical scheme DME facilities on a road tank truck

List of appurtenances as shown on the 'Typical scheme DME facilities on a road tank truck'

Item no.	Description	No. of items	size (inch)
1	Remote controlled bottom valve combined with check valve	1	1¼
2	Remote controlled bottom valve combined with excess flow valve	1	3
3	Check valve	1	2
4	Pressure relief valve	4	¼
5	Block valve	6	2
6	Angle type block valve	1	1¼
7	Filter	1	-
8	Transfer pump	1	-
9	Excess flow valve	2	2
10	Pump overflow valve	1	1¼
11	Safety relief valve	2	2
12	Ullage valve	1	½
13	Block valve	1	½
14	Blow-off valve	3	¼
15	Hose coupling (unloading)	2	-
16	Hose coupling (filling)	1	-
17	Level indicator	1	1
18	Hose reel incl. hose	1	2
19	Flexible joint	1	3
20	Flexible joint	1	2
21	Flow meter	1	2
22	Vapour separator	1	-
23	Differential pressure valve	1	2
24	Pressure indicator	2	½
25	Temperature indicator	1	½
26	Remote controlled bottom valve combined with check valve	1	2
27	Blind flange/cover	1	2

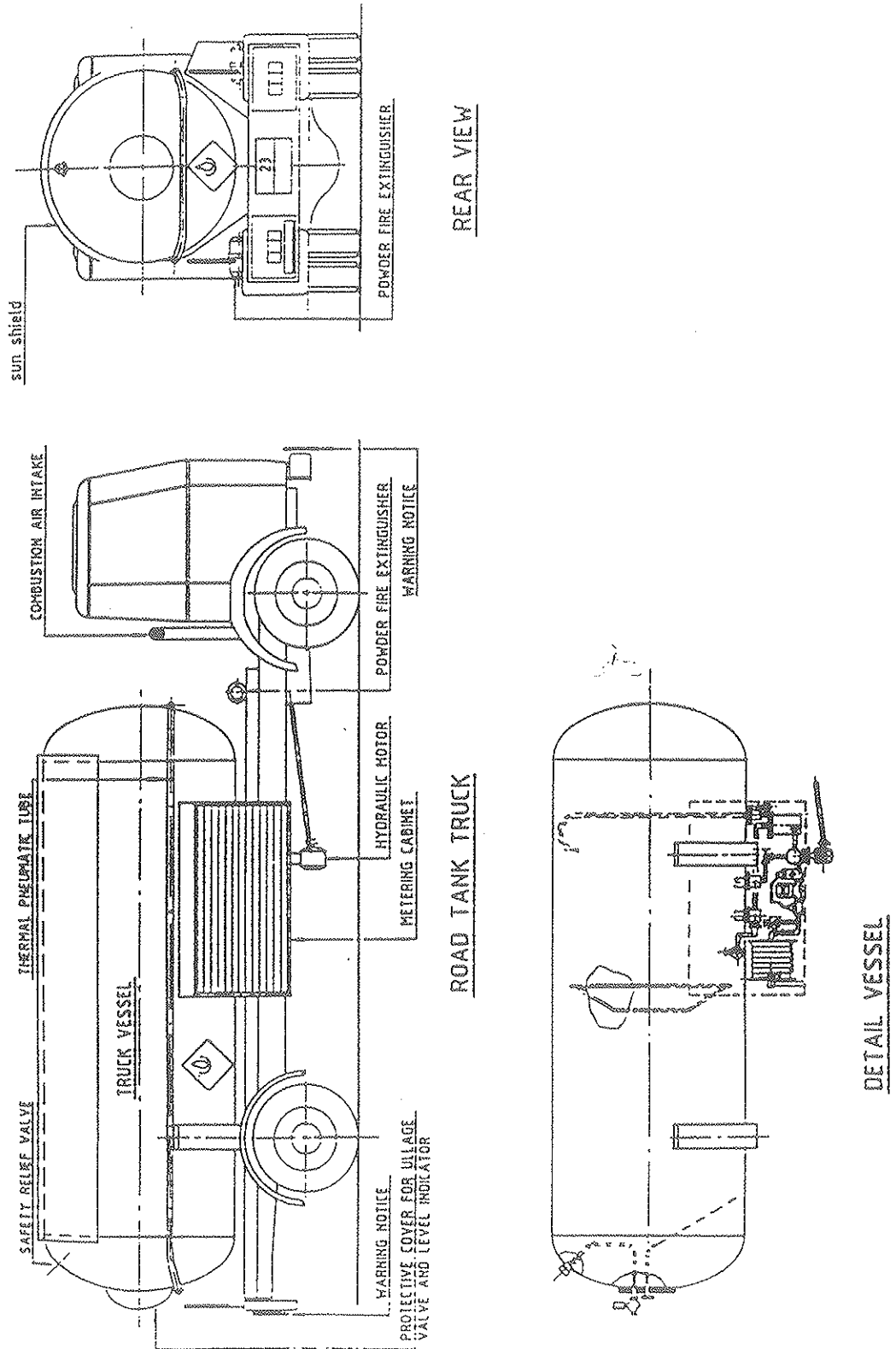

Figure 5.2 Typical road tank truck

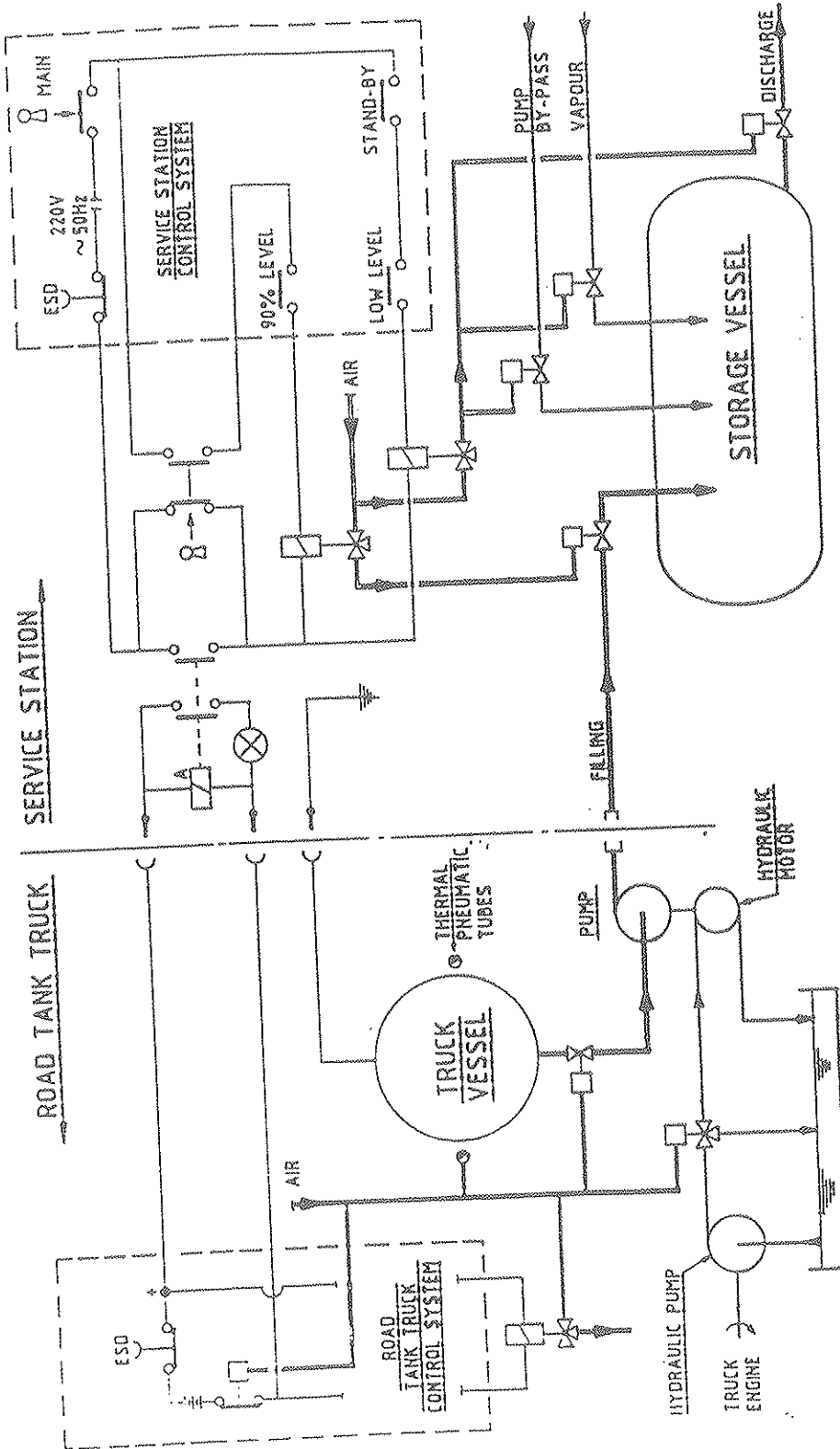

Figure 5.3 Simplified control system

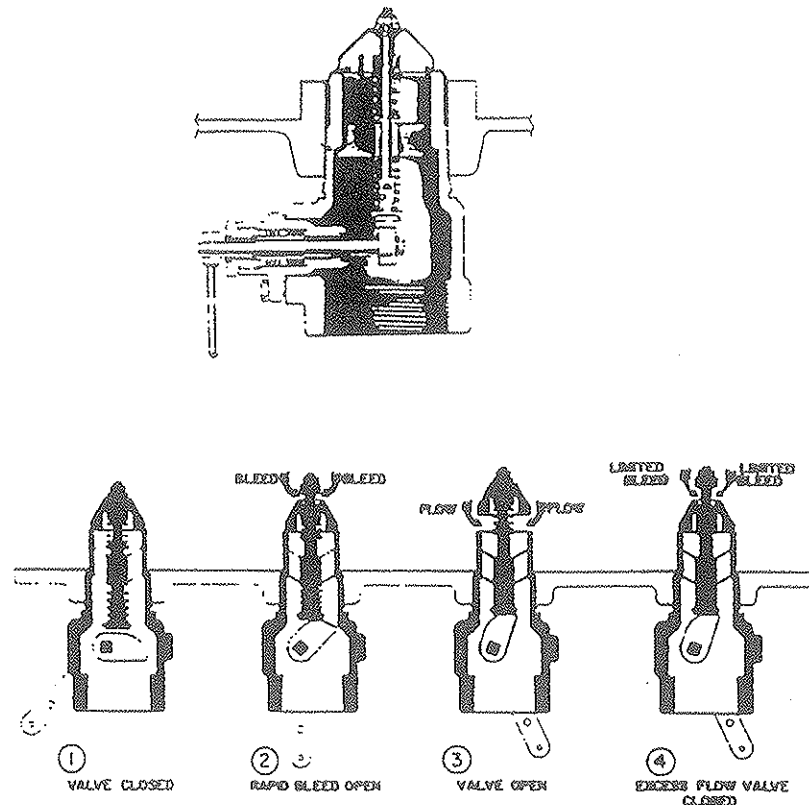

Figure 5.4 Excess flow type bottom valve

### Principle of operation

In view #1, the valve is held closed by both vessel pressure and the valve's closing spring. Moving the operating lever to approximately midpoint in its 70° travel (view #2), allows the cam to place the rapid equalising portion of the valve stem in the pilot opening. This permits a larger amount of product to bleed downstream than if the operating lever were moved to the full open position.

When vessel and downstream pressure are nearly equal after a few seconds, the excess flow spring pushes open the main poppet (view #3), and the operating lever can be moved to the full open position. The system is now ready for the transfer operation, with the main valve acting as an excess flow valve. The pump should not be engaged until the valve opens.

Once the main poppet opens, a flow greater than the valve's excess flow spring rating or a sufficient surge in flow forces the main poppet closed (view #4) - The pilot valve allows a small amount of product to bleed, but much less than in view #2 where the rapid equalisation portion of the stem is in the pilot opening. When the operating lever is moved to the closed position, the valve closes completely and seals tightly (view #1).



## 6. General design requirements

### 6.1 Governing regulations

The design, construction, inspection and testing of DME road tank trucks shall comply with the requirements of the 'European Agreement concerning the International Carriage of Dangerous Goods by Road' (ADR), supplemented by the requirements as set forth in this document.

In appendix XII, the "marginals" (numbers in the margin) of the major requirements of the ADR (1997 edition) concerning vessels, piping and appurtenances for DME facilities have been listed.

### 6.2 Design fluid

The design of the DME containing/related Installation i.e. the vessel with appurtenances and the piping inclusive ancillaries shall be based on handling a fluid which is defined, in compliance with the ADR, as 'a gas liquefied under pressure',

trade name : dimethylether  
class : 2F

### 6.3 Carrying vehicle

The construction of a road tank truck shall be such as to minimise the possibility of deformation of the vessel and its appurtenances due to external forces and shall include a sturdy bumper at the rear of the vehicle as well as horizontal protecting bars on both sides of the vessel.

The combustion air intake of the truck's engine, shall be situated as high as possible but at least 1.50 m above grade.

The cab and engine of the motor vehicle shall be effectively screened from the vessel or any trailer mounted vessel which may be towed by the vehicle. Where the back of the cab is constructed of fire-resisting materials, a fire-resisting shield need not be fitted unless the engine projects beyond the rear of the cab.

There should be a space of not less than 150 mm between the vessel and the back of the cab or fire-resisting shield, where fitted.

### 6.4 Mounting of vessel and piping on the chassis

The vessel shall be fixed mounted on the chassis. Usage of skid-mounted vessels is not allowed for the supply of DME to service stations.

The flexibility of individual components as well as their interaction in this respect must be considered in the overall design. Attention should be given to the attachment of the vessel on the chassis, i.e. a rigid part being connected with a flexible part. This construction may often necessitate the use of an auxiliary frame in order to keep the required flexibility within acceptable limits. For the same reason, piping systems should be provided with flexible joints. This will also prevent vibrations caused by the running DME pump from being transmitted to the whole piping system and will reduce noise and the possibility of pump failures as well.

The appurtenances of a road tank truck shall be protected in such a way, that they are not accessible to unauthorised persons. In case a closed cabinet is used for this purpose, it has to be provided with at least two low situated ventilation openings, located opposite of each other, each having an area of at least 50 cm<sup>2</sup>.

Critical equipment within such a cabinet shall be suitable for zone 1 of the hazardous area classification, and comply with the relevant Cenelec Standards (see § 3.4).

DME related piping systems inclusive appurtenances, shall be located within the horizontal projection of the vessel.

## 6.5 Fire-fighting appliances

A road tank truck shall be equipped with means for fire-fighting according to the requirements of the ADR, i.e. at least two portable fire extinguishers.

## 6.6 Labelling and marking

Every DME road tank truck shall bear on both sides and at the rear a danger label, in the form of a square of not less than 30 cm sides, standing on a corner, conform to the requirements of the ADR. In addition the truck shall display two rectangular reflecting orange coloured plates of 40 cm base and 30 cm high, set in a vertical plane, conform to the requirements of the ADR. They shall be affixed at the front and at the rear of the vehicle.

The hazard-identification number shall be 23, the substance-identification number shall be 1033.

## 7. SAFETY SYSTEMS

Reference is made to figure 5.3, "simplified control system", shown in chapter 5.

### 7.1 Emergency shut-down systems

Each road tank truck shall be provided with an emergency shut-down system, connected with the remote-controlled bottom valves as well as with the driving system of the DME transfer pump: Upon activating the ESD-system, all bottom valves shall close within 15 seconds and the pump will be stopped (stopping the pump will prevent damage due to running dry).

Prior to unloading, the ESD-system of the road tank truck shall be connected to the ESD-system of the service station to be supplied with DME. Activating the truck ESD-system hence will result in de-energising of the station facilities i.e. in closing of the remote-operated shut-off valves of the service station.

Activating of the truck's ESD-system shall be achieved manually by means of ESD push-buttons or automatically due to melting of a thermal pneumatic plastic control tube to the shut-off valves.

At each road tank truck, ESD push-buttons shall be located adjacent to the cabinet(s), housing the unloading and filling equipment, furthermore one push-button each shall be installed at the left-hand side of the front of the vessel and at the right-hand side of the rear of the vessel.

### 7.2 Thermal pneumatic plastic tube

A thermal pneumatic plastic control tube shall be installed horizontally around the vessel at approximately one third of its height and be pressurised by compressed air. Release of the air pressure due to damage caused by heat, fire or otherwise will result in an emergency shut-down. The tubing shall be mounted in a protective enclosure provided with slots, to prevent mechanical damage.

Inside the cabinet the same type of tubing shall be installed to provide compressed air for control and/or actuating of the bottom valves.

### 7.3 Bonding

Reference is made to chapter 11, electrical requirements.

## 7.4 Drive-off alarm

Intermittent visual and audible alarm shall be provided in the driver's cabin (red flashing light on the dashboard and a horn) to warn the driver that the road tank truck is driving away while the unloading hose is either still connected with the filling nozzle or not properly stored (cabinet not closed).

The alarm shall be actuated also when:

- the equipment cabinet(s) is (are) opened without the vehicle's handbrake being (firmly) on;
- the vehicle's handbrake is loosened when the equipment cabinet(s) is (are) opened.

In addition to the drive-off alarm, the remote-controlled bottom valves shall be automatically shut-off when closing the equipment cabinet(s).

## 8. Requirements for DME vessels

In this chapter the requirements are given for the design, fabrication, inspection and testing of road tank truck vessels for the transport of DME. The vessels shall be fixed mounted on the trucks.

### 8.1 Design codes and regulations

Vessels of DME road tank trucks are classified as unfired pressure vessels, which are subjected to the inspection and acceptance of the Inspection Agency.

DME transport vessels shall be designed, fabricated and tested in accordance with the requirements of the ADR in addition to the requirements of BS-5500, "Specification for unfired fusion welded pressure vessels". These vessels shall only be used for the transport of DME.

### 8.2 Vessel volume

The volume of vessels of road tank trucks for DME supply to DME service stations shall be at least 20 cubic metres and shall further comply with the national legislation and the requirements of the Ministry of traffic.

#### Note:

A minimum volume has been specified as a safety measure in order to minimise on the number of transport movements between depots and service stations. Selection of an optimum volume is a matter of logistics whereby e.g. distances and storage capacities of the service stations should be considered.

### 8.3 Degree of filling

The maximum allowable degree of filling by weight shall be calculated in accordance with the ADR: maximum mass of contents per litre vessel volume - 0.95 x density of the liquid phase at 50 °C (see also section 2: §6.1).

In addition, the vessel shall not be filled above 86% by volume (see section 1, § 5.3), this level shall be indicated by the setting of the ullage valve assembly (see § 9.3.1).

### 8.4 Design pressure

The design pressure shall amount to 14 barg for vessels to be provided with a sunshield or thermal insulation and 16 barg for vessels without such provisions [2].

#### Note.

In case of an ambient temperature of 253 K (- 20 °C) during wintertime the pressure in the vessel decreases to approximately 120 kPa. Therefore, for this situation no design pressure below atmospheric pressure has to be specified.

### 8.5 Hydraulic testpressure

The hydraulic testpressure shall be:

- for vessels with a sun protection: 14 barg;
- for vessels without a sun protection: 16 barg.

In case the vessel is equipped with a sun protection, the test pressure shall be at least the vapour pressure of DME at 60°C (= 15.9 barg [3]) minus 1 bar (= 15 barg). For vessels without sun protection the test pressure shall be at least the vapour pressure of DME at 65 °C (= 15.9 barg [3]) minus 1 barg (= 17 barg).

### 8.6 Design temperatures

The minimum and maximum design temperatures shall be 253 K (-20 °C) and 323 K (+50 °C) respectively, unless different requirements due to local climatological conditions or/from authorities having jurisdiction are applicable.

### 8.7 Materials

DME is incompatible with most elastomers. Therefore, DME storage vessels shall be manufactured from a material which is DME resistant, carbon steel or low alloy steel material which is suitable within the temperature range of - 20 °C to + 50 °C and which is not subject to brittle fracture and stress corrosion.

*It is assumed that the supplier of the equipment defines further material specifications for DME, based on the maximum operating conditions of the system.*

Only these materials are allowed which show good welding properties and for which satisfactory impact values measured at a temperature of - 20 °C can be guaranteed, especially in the weld and the heat affected zones. Water hardened steels shall not be used. For fine grain steels, the guaranteed value of the yield stress  $R_e$  as per material specification shall not exceed 460 N/mm and the maximum permitted value of the tensile strength as stated in the material specification shall not exceed 725 N/mm<sup>2</sup>.

In addition to the above, the steel shall meet the requirements of the ADR and be made in accordance with an officially accepted material specification and make as described in the ISO (International Organisation for Standardisation) standards ISO 2605 and 6303 and in the CECOC (Colloque Européen des Organismes de Contrôle) standards R2SICEOC/79, R26/CEOC/79 and R29/CEOC/83.

A procedure for acceptance of manufacturers may be found inter alia in the following document of the CEOC: R49/CEOC/83 "Approval of manufacturers of fittings and flanges".

## 8.8 Vessel connections

### 8.8.1 General

- The number of apertures/connections of a vessel shall be limited to the minimum.
- The vessel shall be provided with suitable closures to allow internal inspection of all vessel sections.
- Vessels having a diameter of more than 1 m, shall be provided with a round manhole.

### 8.8.2 Required connections

Each vessel shall be equipped with connections for:

- a. one or two spring loaded safety valves;
- b. a maximum ullage valve, mounted on a pipe with a built-in restriction having an I.D. of max. 1.8 mm<sup>2</sup> (based on a maximum nominal diameter of 1.5 mm);
- c. a level indicator;
- d. a manometer (preferably combined with b. above);
- e. the discharge of liquid DME;
- f. the filling of liquid DME;  
(e. and f. may be one combined connection);
- g. a pump overflow line in case of combined discharge and filling connection;
- h. an overfill alarm;
- i. a temperature indicator, installed in a thermo-well;
- j. a vapour connection

#### Note:

The vessel shall neither be provided with drain connections nor with vent connections.

### 8.8.3 Location

All connections having a bore more than 1.8 mm<sup>2</sup> (based on a maximum nominal diameter of 1,5 mm), shall be located at the bottom of the vessel between the axles of the road tank truck, except the connections for the safety relief valves, which shall be located as high as possible above the maximum allowable liquid level, in the rear head of the vessel.

The bottom of the vessel shall have no connections from which liquid DME can be discharged other than the connection(s) for filling and discharge and for the pump by-pass/relief.

A vapour connection shall be provided for ingassing purposes only.

#### 8.8.4 Size

For reasons of strength, each nozzle must have a minimum nominal size of DN 50 (2") except for pipe connections having an opening of 1.8 mm<sup>2</sup> (based on a maximum nominal diameter of 1.5 mm), which shall have a nominal size of at least DN 15 (1/2").

*It is assumed that the supplier specifies the minimum nominal size of the nozzle, based on the maximum operating conditions of the system.*

### 8.9 Construction

#### 8.9.1 Manhole

The manhole closure shall be provided with a locked-in seal to prevent blow-out, e.g. a ring type joint facing, male/female facing as per DIN 2513 type R13 (cover facing type V13).

#### 8.9.2 Flanged connections

Except for the allowed threaded connections as described in §8.9.3, the connections at the vessel shall be provided with welding neck flanges or welded-in flanges with studs. To prevent blow-out, all flanges shall be provided with a locked-in seal e.g. a ring type joint facing or male/female facing as per DIN 2513 type R13.

#### 8.9.3 Threaded connections

Connections being located in the vapour section of the vessel (i.e. above the max. allowable liquid level) and having a size of not more than DN 50 (2") may be threaded.

The connection for the level indicator may be threaded also, provided the threaded hole is situated in a removable flange cover.

For threaded connections, the American National Taper Thread (NPT) shall be used only.

Threaded Joints shall be made without using hemp or similar filamentous material.



#### 8.9.4 Bolting

Welded-in flanges shall be provided with studs and nuts. Welding neck flanges shall be provided with suitable stud bolts with a removable nut on each side. Bolting shall be suitably protected against corrosion e.g. by molycote and by sealing the spacing of a flanged joint.

#### 8.9.5 Gaskets and seals

The gaskets to be used, shall be suitable for DME service (DME resistant). Gaskets materials may be selected from the following table.

Type of joint	Acceptable sealing material	Remarks
Flanged	Seal rings/gaskets made from DME resistant material. Quality It 400 or ItC, in accordance with DIN 3754.	Thickness of gaskets not to exceed 3 mm. One ring / gasket only to be used.
Threaded	DME-resistant non-indurating sealant.	Thread to be clean and free from grease. Hemp or similar filaments not allowed.
Couplings with flat sealing face	Sealing made from fibre or equal DME resistant material	Do not use more than one ring.

#### Note:

Elastomers shall not be used as DME attacks most elastomers.

#### 8.10 Name plate

The vessel shall be provided with a corrosion resistant metal plate on which at least the information as required by the ADR shall be die-stamped. The plate shall be irremovably attached to the vessel and be clearly visible.

#### 8.11 Supporting

The vessel shall be provided with saddle plates which shall be continuously welded to the shell to prevent corrosion due to ingress of moisture.

The supports shall be designed in such a way as to prevent unacceptable high local stresses in the vessel shell. The design of the supporting shall be in accordance with the British pressure vessel standard BS 5500.

The supporting shall comply with the requirements of the ADR. This implies amongst other things that the supports and the vessel itself must be designed to

absorb the following forces when loaded with the maximum allowable filling weight:

- in the direction of travel: twice the total mass;
- at right angles to the direction of travel: the total mass;
- vertically upwards: the total mass;
- vertically downwards: twice the total mass.

The supporting shall also be suitable to carry the vessel when completely filled with water.

### 8.12 Anti-sloshing baffles (surge plates)

Vessels having a capacity of more than 7500 l shall be provided with anti-sloshing baffles, which divide the vessel in compartments each having a volume not exceeding 7500 l. The anti-sloshing baffles shall comply with the requirements of the ADR.

### 8.13 Hydrostatic pressure test

The vessel shall be subjected to a hydrostatic pressure test in accordance with the requirements/procedures as described in the pressure vessel design code and the requirements of the Inspection Agency.

Unless specified otherwise, the test pressure shall be maintained for not less than 12 hours. The test pressure shall be 14 barg or 16 barg (see § 8.5).

In addition the vessel connections with installed appurtenances shall be subjected to a pneumatic tightness test at a pressure between 4 and 8 barg and be soap tested at this pressure (see § 10.8 2).

### 8.14 External coating

The vessel shall externally be provided with an anti corrosion coating. Prior to the application of the coating, the mill scale shall be carefully removed and the vessel surface cleaned in accordance with degree SA 2.5 of the Swedish specification SIS-055900.

It is advisable to use a external coating which is DME resistant.

## 9. Vessel appurtenances

Reference is made to appendix II "Appurtenances for dimethylether. List of accepted makes".

### 9.1 General

The vessel and piping of a road tank truck shall be equipped with appurtenances as described hereafter. No appurtenances shall be used of which make and type have not been approved by the Inspection Agency.

### 9.2 Valves

#### 9.2.1 General

All valves shall be made from steel, nodular cast iron or malleable cast iron, provided the material quality is suitable for DME service (DME resistant) and meets the following mechanical requirements: elongation not less than 10 % (measured on  $l = 5d$ ).

All valves having a nominal diameter of DN 50 (2") or smaller may have NPT threaded connections except valves which are installed directly on the nozzles of the vessel. These shall be flanged. Also the valves over DN 50 (2") shall be flanged. All valves having a bore of more than 1.8 mm<sup>2</sup> (based on a nominal diameter of 1.5 mm) and being directly installed on the vessel shall be "fire safe".

#### Note:

A "fire-safe" valve is a valve which, by special construction or special protection, remains tightly shut-off when exposed to fire. The manufacturer's specifications for "fire-safe" valves shall be followed in this respect.

#### 9.2.2 Bottom valves

All filling and discharge connections of vessels shall be provided with internally mounted flanged bottom valves. These bottom valves shall be remotely-controlled, either actuated by air or hydraulically. DME shall not be used for actuating purposes. The valves shall be equipped with open/closed position indicators. In case of fire the bottom valves shall close automatically. The valves must be 'fail safe' i.e. in case the actuating is interrupted, the valves must close within 15 seconds. At a differential pressure, equal to the design pressure of the vessel (14 barg/ 16 barg) the valves shall still provide tight shut-off and be able to be closed as usual; under this condition however they may be opened with auxiliary equipment, since bottom valves being presently available are not operable at such high differential pressures.

### 9.2.3 Excess flow valves and check valves

Each connection of the DME vessel having a bore of more than 1.8 mm<sup>2</sup> (based on a nominal diameter of 1.5 mm) and intended for inlet purposes only shall be provided with a check valve which shall be installed inside the vessel.

Connections of the vessel having a bore of more than 1.8 mm<sup>2</sup> and intended for discharge, shall be provided with an excess flow valve installed inside the vessel. The excess flow valves shall close when the discharge flow exceeds the maximum possible capacity during normal operation. In closed position the bore of an excess flow valve shall not be larger than 1.8 mm<sup>2</sup>. Discharge connections for safety relief valves and the level control shall not be provided with excess flow valves.

#### Note:

In practice bottom valves are usually installed which combine the remote-controlled shut-off function with the functions of an excess flow valve or a check valve. An example of the working of such valves is given in figure 5.4 of chapter 5.

### 9.2.4 Hand-operated block valves

Flanged hand-operated shut-off valves shall be installed on those vessel nozzles not being connections for filling, discharge, safety relief or level control. In addition, hand-operated block valves shall at least be installed at the end of each filling and unloading line. These valves shall be of the soft-seated globe type, in order to prevent leakage due to contamination with solids.

### 9.2.5 Safety valves

Vessels for international transport shall conform the ADR requirements be provided with not more than two safety valves whose aggregate clear cross-sectional area of passage at the seating or seatings shall be not less than 20 cm<sup>2</sup> per 30 m<sup>3</sup> or part thereof of the vessel's capacity. These valves shall be capable of opening automatically at a pressure of between 0.9 and 1.0 times the test pressure of the vessel to which they are fitted. They shall be of such a type as to resist dynamic stresses, including liquid surge. The use of dead weight or counterweight valves is prohibited.

In case the vessels are used for national transports only, the set pressure of the safety valves shall be equal to the design pressure of the storage vessel +10 % = 12.7 barg. The total relief capacity of the safety valves must in such a case at least be equal to:

$$Q=0.3 \times 10.66 \times A^{0.82}$$

where Q = the capacity in m<sup>3</sup> air/min.

Air of 288 K (15°C) at a pressure of 100 kPa.

and A = the external surface of the storage vessel concerned in m<sup>2</sup>.

The safety valves shall be installed directly on the vessel connections. No valves, check valves, excess flow valves and the like shall be installed neither upstream nor downstream a safety valve. The safety valves shall be internally mounted, i.e. the spring must be 1 inside the vessel whilst the disc may just protrude. Drainage of (rain) water must be guaranteed under all conditions.

#### 9.2.6 Pressure relief valves

Piping sections in which liquid can be blocked-in between two shut-off valves must be protected against overpressure by pressure relief valves. These pressure relief valves shall be installed "on the line" and have sufficient blow-off capacity based on the expansion of the DME. *[The set-pressure of the pressure relief valves should be related to the maximum operating pressure of the system.]*

Blow-down of pressure relief valves shall be allowed only at well ventilated and safe locations. Blow-down piping must not be provided with shut-off valves and shall be protected against ingress of rainwater.

#### 9.2.7 Blow-off valves

Just up-stream of hose couplings, blow-off valves may be provided. *[The maximum quantity of DME which is allowed to be blown-off per occasion should be specified].*

### 9.3 Liquid level indicator and filling grade control

#### 9.3.1 Ullage valve assembly

The vessel shall be provided with a fixed internal pipe having an opening of no more than 1.8 mm<sup>2</sup> (based on a maximum nominal diameter of 1.5 mm).

The pipe shall consist of an external and internal section (pipe in pipe). The internal part of the pipe shall extend upwards to the maximum allowable filling level (86 % by volume) as is indicated on the name plate of the vessel. The pipe section outside the vessel shall be provided with an ullage valve and a shut-off valve.

Note:

If the maximum allowed filling level has been reached, a white cloud will become visible when opening the valve. The cloud is caused by condensing water vapour from the air. Gaseous DME escapes colourless.

### 9.3.2 Level indicator

The vessel shall be equipped with a level indicator of suitable construction to meet the design pressure of the vessel. If DME is blown-out at that pressure, the construction shall be such that not more DME is blown out than can pass an opening having a cross-sectional area of  $1.8 \text{ mm}^2$  (based on a maximum nominal diameter of 1.5 mm). The use of gauge glasses is prohibited.

### 9.3.3 Overfill alarm

The vessel shall be equipped with an alarm which shall be activated during filling when the liquid level has reached a certain pre-determined level. Taking the filling velocity into consideration, sufficient time shall be left after the alarm to allow stopping the filling process prior to the liquid level having reached the allowable maximum.

Setting of the alarm at the 81 % level will suffice in this respect.

## 9.4 Pressure and temperature indicators

The vessel shall be provided with a suitable pressure gauge, which is in direct communication with the vapour space above the liquid level. A valve shall be mounted between the vessel and the pressure gauge. This pressure gauge shall preferably be combined with the pipe on which the ullage valve has been mounted.

The accuracy class of the pressure gauge shall be at least 2.5 (maximum deviation 2.5 % from the full-scale end value).

If a vessel is provided with a thermometer, this instrument shall be mounted in such a way that the temperature of the liquid is measured without any part of the thermometer itself coming into contact with the liquid, e.g. by means of a thermo-well.

## 9.5 Filters

Filters shall be made from either cast steel or cast iron (malleable or nodular) provided the quality of the material is suitable for DME service (DME resistant) and meets at least the mechanical properties as specified for valves under § 9.2.

The design pressure shall be at least equal to the test pressure of the vessel.

## 9.6 Transfer pumps

Pumps shall be specifically designed for DME service (due to the poor viscosity and poor lubricity of DME) and be made either from cast steel or cast iron (modular or malleable) which shall meet the mechanical properties as specified for

valves under § 9.2. Pumps shall be provided with an overflow/relief valve to protect the pump casing from overpressure when pumping against a closed discharge. This valve shall discharge back into the DME vessel at a pre-determined set pressure, selected in relation with the pump curve, and the valve shall be of sufficient capacity to handle the maximum pump flow at this pressure.

The maximum differential pressure of the pump (shut-in pressure) shall be taken as 10 bar as a maximum.

*[The design pressure of the pump should be related to the design pressure of the piping system, which has to be specified].*

The connection between pump and piping shall be such that unacceptable mechanical stresses can not occur, e.g. by usage of flexible steel joints, of a type which meets the approval of the Inspection Agency. Elastomers are not acceptable (as DME attacks most elastomers); the material used for this connection should be DME resistant.

## 9.7 Flow meters

*[Flowmeters and their appurtenances shall be suitable for DME service and have a design pressure which is related to the maximum operating pressure of the system.]*

## 9.8 Flexible joints

Flexible joints shall be of a type proven to be suitable for the design conditions.

## 9.9 Hoses and hose reels

### 9.9.1 Hose reel assemblies

Hose reel assemblies shall be suitable for DME service. DME containing parts shall have a design pressure which is in accordance with the maximum operating pressure.

### 9.9.2 Hoses

Filling as well as discharge hoses shall meet the following requirements:

- suitable for DME service. i.e. be DME-resistant;
- *it is assumed that the supplier specifies the certified bursting pressure of the hose.*

### 9.9.3 Hose couplings and adapters

For the connection of hoses, threaded couplings shall be used which shall be of the following type:

Coupling with hexagon swivel nut and with ACME thread, the hose insert part with swivel nut and nipple provided with a spherical seat.

The other coupling half shall be provided with an inserted copper or DME resistant soft seat.

For the attachment of the coupling to the hose, a clamp connection or similar device shall be used, which is not adjustable and not easy to take apart. Clamp connections provided with at least 4 bolts shall be used for hose diameters from 25 mm up to 75 mm and with at least six bolts for hose diameters over 75 mm.

The pressure at which the hydrostatic test should be performed should be specified an at least in accordance with the design pressure of the couplings. The couplings shall not leak nor show any indication of weakening (as in accordance with the requirements of the Inspection Agency).

Adapters shall comply with the above requirements as well.



## 10. Requirements for DME piping

In this section the requirements are given for the design, fabrication, inspection and testing of piping containing liquid and/or gaseous DME.

### 10.1 Design codes and regulations

DME containing piping is subjected to the inspection and acceptance of the Inspection Agency.

The piping shall be designed, fabricated, installed, tested and inspected in accordance with ANSI/ASME B31.3: "Chemical Plant and Petroleum refinery Piping" and as stated in this regulation.

### 10.2 Design and test pressures

*[The design pressure shall be related to the maximum operation pressure of the system].* The hydrostatic test pressure shall be equal to the design pressure.

### 10.3 Design temperatures

The minimum design temperature shall be 253 K (-20 °C), the maximum design temperature is 323 K (+50 °C), unless local climatological conditions and/or authorities having jurisdiction require different criteria (see also § 8.6).

### 10.4 Design

For the DME containing piping including related piping components and ancillaries, the following shall be observed:

- The entire piping system inclusive ancillaries shall be located within the horizontal protection of the vessel.
- The entire piping system, including the appurtenances shall, where possible, be constructed with welded joints and, where necessary, with flanged joints. The number of flanged joints shall be kept down to a minimum, while welding-neck flanges only may be applied.
- Piping and appurtenances with a nominal diameter of at most DN 50 may be joined with a tapered thread according the American National Pipe Taper (NPT), but shall preferably be welded or provided with flanged joints.

The piping systems shall be designed in such a way as to minimise deformations of the bottom valve areas due to external forces.

In addition to the installation of flexible joints, piping systems shall be well secured to minimise vibrations in the best possible way.

Detachable connections shall be readily accessible for maintenance.

## 10.5 Materials

DME is incompatible with most elastomers. Therefore, material for pipe, fittings and flanges shall be manufactured from a material which is DME resistant, low carbon steel or low-alloy steel, suitable to meet the design temperatures and made in accordance with an officially accepted material specification as described in the ISO documents 2634 and 2635.

The carbon content for all materials shall not exceed 0.23 %.

### 10.5.1 Pipe

Pipe shall be seamless and have plain ends, dimensions as per DIN 2448 or BS 360. The maximum specified tensile strength, however, shall not exceed 450 N/mm<sup>2</sup>.

Mechanical properties shall include sufficient impact values at - 20 °C (see also § 10.3).

### 10.5.2 Fittings

Butt-welded forged seamless steel fittings, dimensions as per BS-1640 or DIN 2615 (tees), DIN 2605 (elbows), DIN 2616 (reducers) and DIN 2617 (caps).

Threaded forged seamless steel fittings, dimensions as per BS-3799 or DIN 2980, provided with American National Pipe Taper Thread (NPT).

Acceptable material: ASTM A-234 WPB or equivalent.

### 10.5.3 Flanges

Forged steel welding neck flanges made from C22 material according DIN 17200, ASTM A-105 or equivalent, having a pressure rating PN-40 or ANSI class 300 according ANSI B16.5. Welding neck flanges as per DIN 2635, BS-4504 or equal, are acceptable. The thickness of the welded shall be at least equal to the wall thickness of the matching pipe. Facings should be according DIN 2513 type R13 (cover facing type V13) as described previously in § 8.9.2, however, raised face flanges are also allowed (DIN 2526 form C or equal).

### 10.5.4 Bolting and threaded connections

Reference is made to § 8.9.4 and § 8.3.4.

### 10.5.5 Gaskets and seals

Reference is made to § 8.9.5.

## 10.6 Fabrication

The fabrication and installation of the DME piping and appurtenances shall be carried-out by a qualified contractor. Upon termination of the works, this contractor shall provide a complete set of "as-built" installation drawings; each document stamped "as-built" dated and duly signed.

## 10.7 Welding

### 10.7.1 General

No production welding shall be commenced until:

- Welding procedures and welders performance tests have been qualified in accordance with the applicable welding code and the regulations of the Inspection Agency.
- Welder performance qualifications have been approved by the Inspection Agency.

### 10.7.2 Welding procedure qualification

Welding shall only be carried out in accordance with qualified welding procedure specifications prepared for each welding process, material and service condition, e.g. ASME Section IX, BS 4870/4871, or any other internationally accepted code.

### 10.7.3 Welders performance qualification test

Welders shall pass a performance qualification test in accordance with ASME Section IX, BS 4870/4871, or any other internationally accepted code. Existing welder qualifications are acceptable, provided the qualification is relevant to the welding to be carried-out. Welders must have successfully welded the previous six months.

### 10.7.4 Welder identification

Each welder shall be issued with an identification card.

### 10.7.5 Welding processes

All welding shall be carried-out in accordance with ANSI B 31.3 unless noted otherwise.

#### 10.7.6 Weld inspection

Inspection of welds shall be carried-out prior to any painting, coating or insulation and be carried-out in accordance with ASME/ANSI B 31.3 and as further specified here in. Any weld shall be inspected over its full (circumferential) length.

Radiographic examination shall be performed accordance with section IIS/IIW-492-75 "Recommended practice for radiographic inspection of fusion-welded circumferential joints in steel pipes from 1 mm up to 50 mm wall thickness class B".

All inspections shall be performed under the direction of licensed operators, qualified to the American Society of Non-destructive Testing (ASNT) Level II or equivalent. operators shall be employed by an independent inspection company to be approved by the Inspection Agency. The results of such inspections shall be submitted to the Inspection Agency.

Acceptance criteria of welds shall be in accordance with ANSI B 31.3, table 327.4.1A "Limitations on imperfections in welds".

### 10.8 Pressure testing

#### 10.8.1 Hydrostatic Pressure testing (strength test)

*[The DME piping and appurtenances shall be subjected to a hydrostatic pressure which is equal to the design pressure of the system.]* The pressure shall be maintained for not less than one hour and the test shall be carried-out in accordance with the ASME code section VIII, div. 1 and the requirements of the Inspection Agency.

#### 10.8.2 Pneumatic tightness test

After the hydrostatic strength test has been successfully completed, the DME piping and appurtenances shall be subjected to a pneumatic tightness test at a pressure between 4 and 8 barg. All joints, welds and connections shall be "swabbed" (soap-tested) with a suitable leak detection solution. The pressure shall be measured using precision pressure instruments.

#### 10.8.3 Test Records

All test records shall be properly noted and forwarded to the Inspection Agency.

## 10.9 External corrosion protection

DME piping systems shall be externally protected against corrosion by painting; prior to application of the paint, the surface of the piping and applicable piping components shall be shotblasted to a degree of cleanliness in accordance with Sa 2.5 of the Swedish Specification SIS 055900.

*It is advisable to use an external coating which is DME resistant.*

## 11. Electrical requirements

### 11.1 Hazardous area classification

Areas of an installation shall be classified into danger zones, depending on the likelihood of explosive gas/air mixture occurrences. The following classification shall be used:

#### Zone 0

An area where explosive gas/air mixture is present either continuously or during lengthy periods of time.

#### Zone 1

An area where presence of an explosive gas/air mixture is likely under normal operating conditions.

#### Zone 2

An area where as explosive gas/air mixture will not likely occur or, if it should occur, this will only be for a short period of time.

#### Non-hazardous area

An area where explosive gas/air mixtures are expected to occur either in such quantities or during such a period, that special precautionary measures are required for electrical equipment.

Around the major equipment of the installation and the connected piping, occasionally small quantities will escape. Such leakages are considered as secondary sources of hazard. Considering the number of leakages to be expected, the electrical equipment of the DME facilities shall comply with the requirements of zone 2.

### 11.2 Area zoning

The area zoning in compliance with the above classification shall be as follows:

- electrical equipment inside the storage vessel: zone 0;
- electrical equipment installed in the equipment cabinets: zone 1;
- electrical equipment installed outside the equipment cabinets: zone 2;

### 11.3 Electrical equipment

Electrical equipment shall be suitably protected against atmospheric conditions. In zones 0, 1 and 2 explosion proof electrical equipment shall be applied, which complies with Cenelec standards 50014 up to 50020.

In zone 0, the equipment shall meet EEX-i-IIA-T2, in zone 1 the equipment shall meet EEX-dIIA-T2, in zone 2 the equipment shall meet EEX-e-IIA-T2.

Motors of pumps and compressors shall be provided with a thermal protection device.

A contactor-starter shall be installed near all motors. The purpose and the switching positions shall be clearly indicated on or near each contactor-starter.

#### 11.4 Electrical appliances

The use of transportable electric cables and transportable electrical appliances is not permitted in the danger zones, with the exception of hand-lamps with own power source and approved by the Inspection Agency. No heated objects with a surface temperature in excess of a temperature equal to the auto-ignition temperature (zone 1 and 2) respectively 80% of the auto-ignition temperature (zone 0) or open flames may be present, also smoking is not allowed. The electrical installation within the explosion-hazardous zone shall be capable of being completely switched off by means of one or more circuit-breakers located in a non-hazardous area.

The entire electrical installation shall comply with the installation requirements of standard IEC-BD-384.

#### 11.5 Earthing

The vessel, appurtenances and DME piping shall be electrically bonded to the carrying vehicle. In case of articulated vehicles, the trailer shall be in electrical continuity with the motive unit.

The road tank truck shall be equipped with a connection lug on the vessel to connect an external earthing cable during filling at the depot. The electrical resistance between this lug and the vessel and piping system, shall not be more than 5 Ohm.

The road tank truck shall also be provided with a bonding cable of 15 metres length to discharge static electricity. The cable shall be suitable to be connected to the weatherproof cabinet adjacent to the filling point of a DME service station and shall be combined with the cable to connect the ESD systems of the road tank truck and the service station.

## 12. Inspections and approvals

### 12.1 First inspection

Prior to any inspection/acceptance of the vehicle in its entirety by the Ministry of Traffic; the DME installation, i.e. the vessel with its appurtenances and the DME related piping, shall be inspected and tested by the Inspection Agency in compliance with the statements of the ADR. When the inspection results are considered to be satisfactorily, the Inspection Agency will provide the Owner/Principal of the road tank truck with an inspection certificate. This certificate has to be made available to the Ministry of Traffic before the road tank truck in its entirety is released for service.

#### 12.1.1 DME vessel

Each DME vessel shall be subjected to the inspection and approval of the inspection Agency.

The activities of the Inspection Agency will include:

- Formal approval for construction:  
the approval will be issued after review of the construction drawings, calculations and intended materials;
- Qualification of welding procedures and welders/welding machine operators;
- Approval of construction material:  
If required the Inspection Agency will attend material tests and carry out inspections at the mill and manufacturers shops;
- Fabrication supervision:  
General supervision on workmanship and fabrication procedures, check whether construction materials conform to the certificates, attending hydrostatic pressure tests, review of non-destructive testing results;
- Final acceptance of the vessel at manufacturer's works: this includes an internal and external inspection of the vessel including a check of the overall dimensions, flange ratings and sizes, position of nozzles and type of vessel appurtenances, acceptance of the fabrication report comprising all material certificates, test records, vessel data sheet and construction drawings. Upon acceptance the Inspection Agency will issue an inspection certificate and stamp the nameplate accordingly.

#### 12.1.2 Vessel appurtenances and DME system ancillaries

Vessel appurtenances and DME system ancillaries shall be of a make and type as approved by the inspection Agency. General requirements applicable for the various appurtenances and system components are given in chapter 9; as a guide



for the procedures to be followed to obtain such an approval, reference is made to M080618312 of the "Rules for Pressure Vessels" as attached in Appendix II.

Once the make and type of a particular appurtenance have been approved, in principle identical equipment will be accepted by the Inspection Agency upon receipt of the manufacturer's test and material certificates.

The vessel appurtenances, once installed on the vessel shall be tested/inspected by the Inspection Agency in compliance with the ADR.

This inspection will comprise the following:

- check whether the vessel has been inspected/tested at the manufacturer's shop;
- check whether those vessel appurtenances, requiring individual inspection and testing by the Inspection Agency, conform to the requirements which includes checking the test certificates as well;
- check whether make and type/size of the remaining appurtenances have been officially approved and certified;
- check set pressure and required capacity of safety valves;
- check whether the connections on the vessel are gastight;
- check on proper installation and operation of safety devices and other ancillaries installed on, or related to, the vessel;
- check whether the appurtenances have been installed in accordance with the construction drawings and piping diagrams as previously approved by the Inspection Agency.

### 12.1.3 DME piping systems

The inspection and final acceptance of the DME piping will be performed by the Inspection Agency.

Prior to starting the construction, the Inspection Agency will give:

- approval on welding procedures;
- approval on welder qualifications;
- approval on materials for pipe, fittings, flanges etc.;
- approval on the P & ID's (piping and instrument diagrams) showing the DME related systems in their entirety with all components, safety devices and instruments;
- approval on the appurtenances and ancillaries intended to be installed (check on make and type);
- approval on the construction drawings.

During fabrication the Inspection Agency will supervise the works and check whether the construction materials conform to the certificates.

The final testing and inspection of the installed piping system will comprise:

- check on the welds and piping materials;
- check whether all safety devices have been installed as required;
- verification of the certificates for appurtenances and ancillaries (only approved equipment should have been installed);

- check on the set pressures and capacities of safety valves inclusive a check on proper operation of the safety devices;
- attendance at the pressure testing of the system as described before in § 10.8 and § 8.13.

## 12.2 Final acceptance of the DME installation of the truck

The Inspection Agency will officially accept the DME facilities when the inspection of the vessel and its appurtenances and the inspection/tests of the piping systems as described above were considered satisfactorily.

### 13. Qualification of contractors for work on DME installations

In order to ensure the safe construction and operation of DME installations on DME road tank trucks the governmental Inspection Agency requires contracting companies who want to be active in this field to prove their capabilities. A contractor is only eligible for qualification if, to the satisfaction of the Agency, the contractor meets certain requirements.

These requirements are defined in Appendix III, the "Regulation concerning the qualification of contractors for the construction, maintenance, repair, inspection and testing of DME installations".

This "Regulation for qualification" sets forth the requirements regarding quality of work and company organisation which shall be met by the Contractor. It also describes the procedure to be followed for qualification and rules regarding the duration of validity of qualification.

Contractors which comply with the above mentioned regulation will be issued a Certificate of Registration as DME contractor, permitting them to perform activities in this field.

## 14. List of literature

- [1] Regulations for LPG Service Stations and Road Tank Trucks in The Netherlands  
COMPRIMO report, September 1987
- [2] European Agreement concerning the international Carriage of Dangerous Goods by Road (ADR)  
1997 edition
- [3] Thermodynamic and Physical Property Data  
Carl L. Yaws  
ISBN 0-88415-031-32





*TNO-report*  
TNO-MEP – R 98/29011

## Regulations for DME Service Stations and Road Tank Trucks in the Netherlands

TNO Institute of  
Environmental Sciences,  
Energy Research and  
Process Innovation

### Section 4: Regulations for the management and operation of DME Road Tank trucks

Laan van Westenenk 501  
P.O. Box 342  
7300 AH Apeldoorn  
The Netherlands

Phone +31 55 - 549 34 93  
Fax +31 55 - 541 98 37

Date

10-02-99

Author(s)

S.J. Elbers

Order no.

This draft report is supplied for internal use only and the results may not be made known to third parties as having been produced by TNO.

In this respect attention is drawn to article 8 (liability) and article 4 (rights concerning results) of the Standard Conditions for Research instructions given to TNO.

Keywords

Intended for

All rights reserved

No part of this publication may be reproduced and/or published by print, photoprint, microfilm or any other means without the previous written consent of TNO.

In case this report was drafted on instructions, the rights and obligations of contracting parties are subject to either the Standard Conditions for Research Instructions given to TNO, or the relevant agreement concluded between the contracting parties. Submitting the report for inspection to parties who have a direct interest is permitted.

© 1998 TNO

The Quality System of the TNO Institute of Environmental Sciences, Energy Research and Process Innovation has been certified in accordance with ISO 9001.

The TNO Institute of Environmental Sciences, Energy Research and Process Innovation is a recognised contract research institute for industry and government with expertise in sustainable development and environmentally oriented process innovation.

Netherlands Organisation for  
Applied Scientific Research (TNO)

The Standard Conditions for Research Instructions given to TNO, as filed at the Registry of the District Court and the Chamber of Commerce in The Hague, shall apply to all instructions given to TNO.

## Section 4: Regulations for the management and operation of DME Road Tank trucks

### Table of contents

1. INTRODUCTION .....	4
2. SCOPE.....	5
3. DEFINITION OF TERMS .....	6
4. PRODUCT INFORMATION.....	8
4.1 DME.....	8
4.2 PROPERTIES OF DME.....	8
5. DESCRIPTION OF A DME ROAD TANK TRUCK .....	10
6. DRIVER CERTIFICATE AND TRAINING .....	11
6.1 DRIVER CERTIFICATE .....	11
6.2 INSTRUCTIONS FOR DRIVER TRAINING.....	11
7. GENERAL INSTRUCTIONS FOR DRIVERS .....	12
7.1 DRIVER'S CLOTHING.....	12
7.2 DAILY CHECKLIST FOR DRIVERS.....	12
7.3 PROHIBITIONS .....	12
8. LOADING, TRANSPORT AND DISCHARGE OF DME .....	13
8.1 DRIVER DUTIES AND RESPONSIBILITIES .....	13
8.2 LOADING OF THE TANK TRUCK.....	13
8.3 TRANSPORT OF DME.....	14
8.4 DISCHARGE OF DME .....	15
9. EMERGENCY PROCEDURES .....	17
9.1 DME LEAKAGE AT THE SUPPLY DEPOT .....	17
9.2 DME LEAKAGE AT THE SERVICE STATION.....	17
9.3 DME LEAKAGE DURING TRANSPORT.....	18
10. FIRE-FIGHTING INSTRUCTIONS.....	19
10.1 GENERAL.....	19
10.2 SMALL FIRES .....	19
10.3 LARGE FIRES .....	20
10.4 REPORTING FIRES.....	20
11. MAINTENANCE, REPAIRS AND MODIFICATION .....	21
11.1 MAINTENANCE AND REPAIR .....	21
11.2 MODIFICATIONS .....	21
11.3 WORK PERMIT.....	21



12. PERIODIC INSPECTIONS .....	23
12.1 INSPECTIONS BY TRUCK DRIVER.....	23
12.2 INSPECTIONS BY QUALIFIED CONTRACTOR .....	23
12.3 INSPECTIONS BY THE INSPECTION AGENCY.....	23
12.3.1 3-years periodic inspection.....	24
12.3.2 6 years periodic inspection.....	24
12.3.3 Inspection during modifications .....	26
12.4 VEHICLE INSPECTION .....	27
13. INSTALLATION BOOK.....	28
14. LIST OF LITERATURE .....	29

#### Applicable appendices

III	Regulations concerning the qualification of contractors for the construction, maintenance, repair, inspection and testing of DME-installations
IV	Procedure for the commissioning of new or degassed DME-installations
V	Procedure for depressurising and degassing the DME-installation
VII	ADR-product card (transport emergency group card)
VIII	Medical first aid
IX	Example of emergency plan
XI	Installation book for DME tank truck drivers and truck owners
XIII	Checklists for inspection of DME service stations

## 1. Introduction

This section forms part of the 'Regulations for DME Service Stations and Road Tank Trucks'. It provides the regulations for the management and operation of DME tank trucks.

The 'Regulations concerning the management and operation of DME Road Tank trucks' given in this section, are based on existing regulations and guidelines for LPG Road Tank trucks [1] and made specific for DME where necessary.

The application of the 'Regulations' as mentioned in this section will contribute to the safe management and operation of DME facilities on road tank trucks and to the prevention of hazards.

While every effort has been made to ensure the accuracy and reliability of the data contained in these regulations, neither TNO nor the authors shall be held responsible or liable in any way for loss or damage resulting from their use or from any violation of state or international regulations with which they may conflict.

The regulations also cannot be deemed to contain all conditions that must be necessarily be fulfilled for safe construction and usage. The liability remains with principals, manufacturers and the management for the installation.

## 2. Scope

This section covers the requirements related to the management and operation of DME facilities on road tank trucks . It provides guidance for the safe loading, transit and discharge of DME and of the driver's duties and responsibilities in this respect.

It also contains information on the properties of DME, instructions for driver training as well as inspection and maintenance procedures, emergency procedures and fire-fighting instructions.

Furthermore reference is made in this section to applicable appendices of the 'Regulations' which contain information regarding: regulations for the qualification as DME contractor, the contents of an 'Installation Book', an example of an 'Emergency plan', first aid measures, procedures for depressurisation and degassing of DME installations and for the commissioning of new or degasses installations, as well as a listing of applicable articles of the ADR.

Aspects of design and construction of DME road tank trucks are covered in section 3, 'Regulations for the design and construction of DME Road Tank Trucks', which also forms part of the 'Regulations for DME Service Stations and Road Tank Trucks'.

### 3. Definition of terms

For the purpose of these Regulations the following definitions shall hold:

*ADR*

European Agreement concerning the international Carriage of Dangerous Goods by Road.

*BLEVE*

‘Boiling Liquid Expanding Vapour Explosion’

An explosion caused by the sudden formation and subsequent ignition of large quantities of DME vapours, normally due to rupture of a storage vessel.

*Contractor (qualified)*

Contractor is a company which carries-out activities in the field of construction, maintenance, repair, inspection and testing of DME installations. A qualified contractor has acquired a valid certificate of registration from the Inspection Agency.

*Degassing*

Degassing is the procedure by which the gas concentration in a storage vessel and/or related piping system is safely reduced and then maintained at a level which is not higher than 10% of the lower explosion limit.

*DME*

Di-methyl ether, which is used as fuel for motorcars

*DME delivery column*

An apparatus designed for deliveries of DME into DME tanks of motorcars, also called dispenser column.

*DME road tank truck*

A truck, equipped with a storage vessel and appurtenances, especially designed for the transport of DME by road.

*DME service station*

An establishment containing facilities where DME is stored and dispensed to motorcars.

*Filling point*

The connection point for the hose of the tank truck. At this point DME is transferred from the road tank truck to the installation. The tank truck is unloaded, the storage vessel filled.

*Ingassing*

The procedure by which DME is transferred into a gasfree DME storage vessel and /or piping system, thereby increasing the gas concentration up to a level well exceeding the upper explosion limit.

*Inspection Agency*

An institution, governmental or private, authorised to perform inspection work on a DME installation or part there-of. This includes all matters related to the engineering, fabrication, inspection and testing of such installations.

*Mounded storage vessel*

A DME storage vessel, installed above grade completely covered by a mound made of sand covered with tiles.

*Principal*

The company which initiates and ultimately pays for the design and construction of a DME service station and hence will be involved in the control of the quality of the station's facilities and the services rendered.

*'Regulations'*

The Regulations for DME Service Stations and Road Tank trucks.

## 4. Product information

### 4.1 DME

Dimethyl ether is produced from 'syngas' by means of a catalytic process. Syngas is a mixture of hydrogen, carbon monoxide and carbon dioxide which is often used by the industry as an intermediate step for the production of many chemicals and also for power generation. Syngas can be made from a variety of feedstock such as natural gas and coal, but also from renewable feedstock like wood.

### 4.2 Properties of DME

DME is in the vapour phase at atmospheric pressure and normal ambient temperatures: the atmospheric boiling point of DME is - 24.8 °C. Liquefaction of DME at ambient temperatures requires pressurisation. Typically, the vapour pressure of DME is approximately 5.3 bar at 20 °C.

If the pressure is reduced to atmospheric, e.g. by leakage, DME evaporates quickly. When DME evaporates it expands to about 350 times its original liquid volume and, as gaseous DME is approximately 1.8 times as heavy as air, spreads out at ground level accumulating in low places as cellars or sewers.

During evaporation the temperature of DME reduces. When mixed with air this causes condensation of the water vapours in the air and a visible cloud of the gas /air mixture is formed.

If, however, DME in the gaseous state is released into the atmosphere, this gas remain invisible.

DME becomes explosive when mixed with air. A mixture of containing between approximately 3.4 vol% and 18 vol% of DME in air is within the explosion limits and is highly flammable. A small spark or the presence of static electricity could already cause an explosion.

DME does not have to be classified as a dangerous toxic substance. However, DME produces an anaesthetic or narcotic effect with inhalation of vapours. Concentration of 5-20 % by volume can cause irritation, incoordination, shortness of breath, drowsiness, intoxication, blurring of vision, headaches, dizziness, excitation, and unconsciousness. These appear to be short-term effects caused by short-term exposure.

DME in higher concentrations, in excess of 20 %, can increase the risk of cardiac irregularities and possible cardiac arrest. In high concentrations DME replaces breathing air and acts as a simple asphyxiant. This is the result of the displacement and lack of oxygen.

Although DME has a slight ethereal odour an odorant will need to be added to aid in detection of leaks.

The detection of leaks should be by the use a suitable gas detector and NEVER WITH A NAKED FLAME.

Liquid DME is lighter than water and therefore water, if present in a road tank truck or storage vessel will collect at the bottom of the vessel. Besides, DME is soluble in water through which part of the DME will be within the water phase.

DME is not corrosive to steel, which is used in the construction of road tank truck and storage vessels and piping, but attacks most elastomers.

Furthermore, DME is a poor conductor and has a poor fuel viscosity and lubricity through which the design of the appurtenances such as pumps, meters etc. is affected.

## 5. Description of a DME road tank truck

In the "Regulations for the design and construction of DME road tank trucks" (section 3), a description is given of an DME road tank truck, including a typical scheme of the truck's DME facilities and a sketch of a typical road tank truck.

This description should be considered as typical only. Each driver must become familiar with the particularities of his truck and shall therefore be provided with a similar description for his own truck, which shall be kept as part of his documentation in the cab of the truck.



## **6. Driver certificate and training**

### **6.1 Driver certificate**

Conform the regulations as stated in the ADR, the driver of a tank truck on international routes is required to be in possession of a valid ADR-driver certificate.

This certificate shall also be made mandatory for the transport of dangerous goods on internal routes. The driver of a DME tank truck shall in addition be required to obtain an annotation on his certificate, stating that he/she has successfully completed a training course for the transport and handling of DME.

### **6.2 Instructions for driver training**

All drivers handling DME road tank trucks shall be given training so that they are familiar with the duties they are expected to perform in accordance with these regulations. They shall also be made familiar with the properties of DME.

The training syllabus shall be designed to familiarise the driver with the types of customer storage vessels and facilities and their sittings, as well as with the routing for transport of dangerous goods.

Emergency procedures and the procedures for reporting accidents, both written and verbal, shall be included in the training.

Practical training in fire-fighting and the application of medical first aid (see Appendix VIII), shall be given.

It is recommended that the driver undergoes a refresher course at intervals not exceeding 5 years. A record of the driver's training shall be kept by the employer.

## 7. General instructions for drivers

### 7.1 Driver's clothing

When performing operations with DME, the driver shall wear gloves and ensure that the body and arms are completely covered. In no circumstances shall steel-studded footwear be worn.

### 7.2 Daily checklist for drivers

The driver must carry out the following checks before commencing work:

- visually inspect the road tank truck for tightness and for any damage which may have occurred;
- check the condition and pressure of the tyres of the tank truck;
- check the electrical system including the battery;
- check the engine - water, oil, etc.;
- check the hydraulic fluid level in the brakes;
- check the level of the fuel in the tank and also check the cap for tightness;
- operate the emergency lamps (if carried);
- verify the presence of the fire extinguishers;
- check that the correct documentation is in the cab of the road tank truck;
- start the engine and test the brakes;
- check that emergency safety devices are operational.

#### Note:

This also applies when the driver takes over a loaded truck from an other driver. In addition, he shall check the loading bill to ensure that the correct product has been loaded.

### 7.3 Prohibitions

The driver is not allowed to: drink alcohol in excess of any permitted limit before and during driving the road tank truck; smoke on the road tank truck; carry an unauthorised person or persons on the tank truck.

The driver shall conform to the speed limits prevailing in the country in which the tanker is driven, or observe the individual Company's operating maximum speed where this is applicable.

The driver shall make the tank truck safe at each stop by switching off the ignition system, applying the hand brake and placing the wheel chocks in position if the ground is uneven.

## **8. Loading, transport and discharge of DME**

### **8.1 Driver duties and responsibilities**

The main responsibility for safe handling of DME rests with "the employer". "The employer" could be a different one for each handling stage. e.g.:

- during loading: the management of the refinery or supply depot;
- during transport: the management of the transport company;
- during discharge: the management of the service station.

The driver is an employee of the transport company. If he/she is authorised to perform activities during loading or discharge of DME and abides by the rules, the main responsibility for safety remains with the employer of the loading or discharge facilities. If, however, he/she is not authorised or does not follow the correct procedures, the management of the transport company could be held responsible.

The driver has his/her own duties and responsibilities.

These comprise:

- compliance with the general instructions for drivers (see chapter 7);
- performance of DME handling activities in accordance with the relevant procedures as made available to him/her;
- usage of the emergency and fire-fighting procedures in case of hazards. This includes alerting people in the surroundings.

The driver shall not be made responsible for depressurization and degassing or for ingassing of the truck vessel. The purging and first filling of the vessel shall be carried out by a qualified contractor which shall adhere to the degassing and ingassing procedures as given in the Appendices IV and V.

### **8.2 Loading of the tank truck**

Loading of the tank truck shall be carried out in accordance with the following procedures:

- the driver shall position the vehicle at the designated area of the supply depot, facing the direction of departure;
- the driver shall stop the engine, apply the hand brake and place the wheel chocks in position if the ground is sloping;
- the driver shall open the metering cabinet, which energises the drive-off alarm installation;
- the supply depot operator shall connect the earthing cable between road tank truck and filling point;
- the driver shall carefully remove the protective cap or flange from the filling connection;

- the depot operator shall connect the hose or loading arm from the supply manifold to the tank truck filling valve, using only spark-free tools if any;
- the driver shall check all connections for tightness and open the filling valves;
- the driver shall establish the remaining contents of the vessel, where after the depot operator shall establish, either by weight or by volume, the maximum supply quantity;

Note:

The maximum filling grade (volume) and filling weight are marked on the tank truck;

- the depot operator shall open the valves on the supply depot, check all depot connections for tightness, and start the pump. If loading occurs on a weighbridge or by means of a volume meter with pre-setting and automatic stopping device, the exact filling quantity shall be set prior to starting the pump;
- the depot operator shall remain in close proximity to the tank truck throughout the filling operation and check whether filling proceeds normally and especially whether the maximum filling level is not exceeded;
- if overfilling has occurred, the driver shall contact the depot supervisor, so that appropriate action can be taken;
- when the maximum filling level has been reached, filling shall be stopped by stopping the pump and closure of the valves, where after the small amounts of DME which are enclosed between the connections shall be vented before disconnecting the supply manifold;

Note :

Stoppage of the pump may be indicated by one of the following provisions:

- a. a rotogauge of the road tank truck;
- b. the volume meter and/or the automatic stopping device of the meter of the depot;
- c. the weighbridge and/or the automatic stopping device of the weighbridge;
- d. the independently working pre-alarm of the road tank truck.

- the driver shall replace the blanking cap or flange on the filling connection; the depot operator shall disconnect the earthing cable;
- the driver shall visually inspect the truck for leak tightness, close the cabinet, take receipt of the loading documents, remove the wheel chocks (if used) and start the engine

Note:

If the truck driver is authorised by the employers of the supply depot, he may take over the filling operation from the supply depot operator.

### 8.3 Transport of DME

- during transport of DME, the driver must conform with the laws/regulations of the country in which he is driving and when parking only do so in a permitted place and not in the proximity of inhabited buildings.
- the driver shall ensure that the tank truck is never parked in a heavily congested area;
- in the event of vehicle immobilisation when on the road, reflecting triangles shall be placed by the driver one 30 metres behind and another at 10 metres in front of the road tank truck or at any other prescribed distance in order to conform with the regulations of the country in which the tank truck is operating.

If during transport the driver discovers a gas leakage, he/she shall act in accordance with the emergency and/or fire-fighting procedures as described in chapters 9 and 10.

### 8.4 Discharge of DME

The discharge of DME into the storage vessel of an DME service station shall be carried out by the driver in accordance with the following procedure.

The driver shall:

- ensure that the area is safe for unloading;
- position the vehicle at the designated area of the service station, facing the direction of departure;
- stop the engine, apply the handbrake and place wheel chocks in position if the ground is sloping;
- inform the attendant of the service station that he intends unloading;
- read off the contents gauge of the storage vessel,
- visually inspect the vessel connections for tightness and establish the maximum filling load;
- open the metering cabinet of his truck which energises the drive-off alarm;
- connect the connection cable with the filling point of the service station. This provides earthing and ensures the connection of the truck's emergency shut-down (ESD) system with that of the service station;
- carefully remove the protection caps or flanges from the hose connections and connect the hose to the filling point, using only spark-free tools if any;
- inspect the filling point connection for tightness;
- apply the switch key of the switch at the filling point in order to open the remote-controlled filling valve of the service station;
- start the engine of the truck, open the push-button operated remote controlled bottom-valves of the truck's vessel and the hand-operated block valves and start the pump;

- remain in close proximity of the truck throughout the unloading operation and check on the level gauge installed near the filling point whether the maximum filling level of the storage vessel is not exceeded;
- stop the pump timely before the maximum filling level would be reached. A pre-alarm with a setting of approximately 5 vol% below the maximum level should provide an early warning to the driver;
- close the filling valves of the tank truck including the remote controlled valves and stop the engine;
- apply the switch key at the filling point to close the remote-controlled filling valve of the station, close the hand-operated filling valve at the filling point and vent the small amounts of DME enclosed between the connections;
- disconnect the hose. Replace the protective cap or flange on the hose-end and filling point and put the hose back on the hosereel;
- disconnect the cable which provided the earthing and coupling of ESD-systems;
- establish and put on record the exact amount loaded and close the cabinet. This de-activates the drive-off alarm, and on some trucks also the remote-controlled valves and the pump switch;
- visually inspect the storage vessel, filling point and tank truck for leak-tightness and inform the attendant of the station that the loading operation is ended;
- remove the wheel chocks (if used), start the engine and drive-off.

## 9. Emergency procedures

### 9.1 DME leakage at the supply depot

In the event that a driver notices a gas leakage at the supply depot, whether from depot or from tank truck equipment, he/she shall:

- immediately warn the depot supervisor;
- offer assistance to this supervisor and accept his/her instructions;
- not make use of the truck's ESD system to close the bottom valves, unless requested to do so by the supervisor.

Note:

Although a leakage could occur at the tank truck as well as the depot equipment, the driver is on the depot area and should not take any actions which could have repercussions for the safety on the depot. Skilled personnel should be present at the depot, capable to take the required actions. The driver shall not activate the truck's ESD system, before requested to do so, because this would increase the pressure upstream of the bottom valves (e.g. in the loading arm/hose) if the DME loading pump of the depot is still running.

If however the ESD-systems of the depot and tank truck are designed to be interconnected in a similar way as described for tank truck and service station, the driver could activate the truck's ESD-system as this would then stop the loading pump as well.

### 9.2 DME leakage at the service station

In the event that a driver notices a gas leakage at the service station, or if a leakage occurs during filling of the vessel (e.g. a hose burst), he/she shall:

- activate the truck's ESD system and/or switch-off the battery master switch, which should stop the pump and close the truck's bottom valves as well as the remote-controlled valves of the station;
- stop the truck's engine;
- warn the attendant of the station and inform him about the extent of the leakage (if the attendant remains unaware of the leak, he/she may open the station's valves again);
- try to stop the leakage;
- If not successful in his attempts to stop the leak, inform the attendant, who shall then execute the emergency plan;
- assist the attendant in taking the necessary actions: e.g. warn the fire-brigade and his technical supervisor, isolate the area and warn people in the surroundings.

Under no circumstances he/she shall try to start the truck's engine again before the surrounding area has been made safe.

### 9.3 DME leakage during transport

In the unlikely event of an DME leak developing during normal transport, he/she shall check the open/closed position of the bottom valves and shall attempt to stop the leak.

If this is not immediately possible he/she shall drive the truck off the highway in a carefully controlled manner, if this to his/her own judgement is possible, and shall than attempt to stop the leak after first stopping the engine and switching off all electrical circuits on the road tank truck.

If the leakage cannot be stopped, the driver shall seek assistance immediately in order to isolate the area from the public, forbid smoking or the presence of naked lights, call the Police and the Fire Brigade, keep the fire extinguishers ready and remain near the tank truck at the end facing the wind and avoid making sparks with the tools.

The driver must hand the ADR Standard Product Card or equivalent to the Police or Fire Brigade on arrival at the site. The driver must also remember that DME vapours are heavier than air and that they tend therefore to collect in ditches and other low-lying areas.

In the event that a leakage is followed by fire, he/she shall act in accordance with the fire-fighting instructions.

Note:

If a leakage is caused by an accident, this will in many cases create a situation whereby the escape of gas is beyond control of the driver.

If this occurs, he/she shall in any case try to stop the engine, turn-off the battery master switch, seek assistance to evacuate the area and have the firebrigade warned.



## 10. Fire-fighting instructions

### 10.1 General

If a fire breaks out on a DME tank truck, the driver shall immediately stop the engine, activate the ESD system and turn the battery master switch to the "off" position. The fire shall be tackled resolutely with the truck's fire extinguishers.

If the driver is not virtually immediately successful in his attempts to stop the fire, or if the fire appears to large to handle from the outset, he/she shall:

- contact the local Fire Brigade and Police and hand over the ADR product card at their arrival;
- seek assistance to isolate the area;
- inform his supervisor who is then responsible for taking further action.

### 10.2 Small fires

Fires involving equipment in the cab of the engine shall be tackled by the driver using the truck's fire extinguishers or other available dry powder or vaporising liquid extinguishers. If these are not available or have become expended, earth or sand may be used.

Fire involving tyres and/or wheels and hubs of the truck are persistent and are difficult to extinguish. The driver shall attempt to control them by the use of the dry powder type of extinguisher applied in short bursts. Preferably, water should be used in copious quantities, if available.

Note:

First quench the tyre and tube and then attempt to cool the wheel and the hub. Extreme caution should be exercised as the latter may be red hot and hence be a source of ignition.

The driver shall attempt to extinguish fires involving DME by the use of the dry powder type of extinguisher directing the extinguishing agent to the base of the flame.

In the case of small leaks, it may be possible to stop these by closing all valves and extinguishing the fire. If the leak persists but the fire is extinguished, the driver shall make further attempts to stop the leak.

If the fire is small and "safe", consideration should be given to allowing it to burn rather than face the risk of explosion due to leakage of unignited gas.

### 10.3 Large fires

In the case of fire occurring as the result of a large leak:

- stop the engine and activate the ESD system;
- if the flame is not impinging on the tank shell, no attempt should be made to extinguish the flame unless the leakage can be stopped or reduced to manageable proportions;
- if the flame is impinging on the tank shell, there is a real risk of explosion (BLEVE) due to structural failure of the tank, unless copious quantities of water are applied to keep the tank cool.

If cooling is insufficient, an increase in the noise level or flame size will indicate rising tank pressure and an immediate decision should be taken to evacuate the area.

### 10.4 Reporting fires

The driver shall report in writing all fires associated with the road tank truck or with the customer's installation so that the cause can be investigated.

The driver shall hand the report of any incident to his supervisor.

## 11. Maintenance, repairs and modification

### 11.1 Maintenance and repair

The installation shall be maintained in a good state at all times.

Maintenance work and repairs shall be carried-out by a qualified contractor. Repairs to components of the DME containing part of the installation shall at all times be discussed with and approved by the Inspection Agency prior to commencing the work.

The repair shall be recorded in the installation logbook. Replacement of appurtenances by identical parts does not require reporting, but shall also be recorded in the logbook.

No work involving the use of fire or work which may cause leakage or fire shall be performed on vessel, piping and appurtenances unless the installation (part) has been depressurized and degassed. This shall be done in a safe manner and in accordance with the relevant procedure.

### 11.2 Modifications

Modifications shall prior to the execution of the work be discussed with and approved by the Inspection Agency and be carried-out by a qualified contractor. The modifications shall be incorporated in the installation schemes and drawings and be recorded in the installation logbook.

No work involving the use of fire or work which may cause leakages or fire shall be performed on vessel, piping and/or appurtenances unless the installation (part) has been depressurized and degassed. This shall be done in a safe manner and in accordance with the relevant procedure.

### 11.3 Work permit

Prior to starting modification, repair, maintenance cleaning work which requires depressurization or degassing, the work shall be properly planned and appropriate measures must have been taken in consultation with the persons involved in carrying out the work.

*It should be specified which amount of DME should be involved in the event that (part of) the installation has to be depressurised or degassed, before the measures concerned must be laid down in writing and signed by or on behalf of the principal and by the contractor representative (work permit).*

The work permit shall:

- be dated with a maximum daily extension of five consecutive days. Each Monday a new work permit shall be issued;
- be extended to include other work if during execution of the originally envisaged and permitted activities this proves necessary;
- be renewed if the work has been interrupted for special reasons;
- be renewed if other persons than those to whom the work permit was granted are to execute the work;
- be handed-over to the company representative when the work is finished;
- be filed in the installation book for DME tank truck drivers and truck owners and be presented on request of personnel involved or the relevant authorities.

## 12. Periodic inspections

The truck and its DME facilities shall be periodically inspected. These inspections shall comprise:

- daily routine inspections by the truck driver of the carrier-vehicle and its DME facilities;
- six-monthly inspections of the DME facilities by a qualified contractor;
- inspections of the DME facilities by the Inspection Agency at three and six years intervals and further after modifications or major repairs;
- yearly inspections of the carrier-vehicle.

### 12.1 Inspections by truck driver

Regular inspections by the truck driver and/or his/her supervisor in accordance with the instructions as laid down in the driver's handbook.

### 12.2 Inspections by qualified contractor

In addition to these routine inspections, the DME facilities shall at least once every six month be inspected by a qualified contractor. This shall comprise:

- visual external inspection for corrosion of vessel piping and appurtenances;
- visual external inspection of vessel supports;
- visual external inspection and checking of the proper functioning of the appurtenances, e.g. the safety valves and emergency shut-down system;
- check of the proper functioning (complete closure) of the bottom valves when the pressure on the actuators is released;
- check for gas tightness of the installation by applying a soap solution at the prevailing DME pressure;
- check of the fire-fighting equipment.
- visual check on each filling hose in addition to a hydraulic pressure test of *[The set pressure of the hydraulic pressure test should be related to the maximum operating pressure of the system]* barg. In case hoses are found to be deficient, they shall be replaced. Each hose inspection shall be individually recorded.

Inspection reports shall be recorded in the installation logbook.

### 12.3 Inspections by the Inspection Agency

The periodic 3-year and 6-year inspections are performed by the Inspection Agency at the shop of a qualified contractor. The contractor will carry out all necessary preparations prior to an inspection and will give assistance during the inspection whenever required. The individual items to be inspected are listed hereunder; in addition the related activities have been summarised and/or explained.

### 12.3.1 3-years periodic inspection

The Inspection comprises:

- Internal inspection of the vessel and - at the same time -
  - Visual inspection of valves and appurtenances located inside the vessel including a performance check.  
Prior to the internal inspection, the vessel is cleaned with fresh water and dried with rags.  
The safety valves are removed.  
The internal inspection of the vessel comprises a visual check on corrosion/pittings, any dents, cracks or other damage of the vessel walls. Anti-sloshing baffles are inspected thoroughly including their fastening to the vessel walls.  
In case extensive corrosion/pittings are discovered, the inspector of the Inspection Agency may decide to have the wall thickness of the entire vessel electronically measured to check whether the wall thickness still meets the minimum required value.
- External inspection of the vessel and the appurtenances including a performance check of these appurtenances.
- Adjustment of the safety valve(s) set pressure and sealing the valve(s).  
The setting may be established by means of a nitrogen bottle and a standard pressure reducing assembly with manometer.
- Inspection of the piping system and its appurtenances.  
The piping and piping components are checked against the certified drawings including the appurtenance list. Visually the valves are inspected whether they perform well and whether they are of an approved make and type.
- Tightness check of the vessel connections at 6 barg by means of nitrogen or air - and at the same time -
- Tightness check of components of the piping system with its components.  
  
All flanged and threaded connections are being checked by means of a "soap-test".
- Check of vessel name plate, stamping the name plate.

### 12.3.2 6 years periodic inspection

The inspection comprises:

- Certificate of the de-gassing available.  
A road tank truck will not be accepted for inspection without a certificate (issued by an officially recognised company specialised in this field)

confirming the vessel has been degassed and is safe. De-gassing to be performed as described in Appendix V of the "Regulations".

- Internal inspection of the vessel and - and the same time -
- Visual inspection of valves and appurtenances located inside the vessel including a performance check.  
Prior to the internal inspection, the vessel is cleaned with fresh water and dried with rags.  
The safety valves are removed.  
The internal inspection of the vessel comprises a visual check on corrosion/pittings, any dents, cracks or other damage of the vessel walls. Anti-sloshing baffles are inspected thoroughly including their fastening to the vessel walls.  
In case extensive corrosion/pittings are discovered, the inspector of the Inspection Agency may decide to have the wall thickness of the entire vessel electronically measured to check whether the wall thickness still meets the minimum required value.
- External inspection of the vessel and the appurtenances including a performance check of these appurtenances.
- Checking of the vessel supporting on cracks and other shortcomings and a dimensional check against the certified drawings.  
During the inspection of the vessel and its supporting structure, mainly the critical spots are visually inspected such as welds at the saddle plates and the connection of the vessel to the supporting structure.  
The vessel appurtenances and the vessel dimensions are checked against the certified drawings and in addition the type and make of the appurtenances is checked as well as their performance.
- Adjustment of the safety valve(s) set pressure after sealing of the valve(s).  
The setting may be established by means of a nitrogen bottle and a standard pressure reducing assembly with manometer.

- Inspection of the piping system and its appurtenances.  
The piping and piping components are checked against the certified drawings including the appurtenance list. Visually the valves are inspected whether they perform well and whether they are of an approved make and type.
- Hydrostatic pressure testing the vessel and - at the same time -
- Hydrostatic pressure testing of the piping system.  
When filled with water, the vessel and the piping system is pressurised. It should be ensured that the connections of the safety valves have been blinded off. One of the blinds should be provided with a vent to facilitate the filling of the vessel with water up to the highest point (i.e. the relief valve connection). The filling is done with a centrifugal filling pump, whereas pressure is achieved by means of a small piston pump or equal.  
Normal practice is that the contractor does the filling (which may take quite some time) after which the Inspection Agency is notified. The pressure test is performed in accordance with T-0240 of the "Rules for Pressure Vessels".  
Mostly pumps and especially metering devices have to be blinded off or completely removed to avoid damage due to excessive pressure.  
The vessel and piping system are checked on leakage.  
The performance of the bottom valves is checked by suddenly opening a discharge valve thus simulating a line break.  
Upon successful testing, the vessel and piping system is emptied. The vessel is dried by means of rags, the piping by purging with compressed air.
- Tightness check of the vessel connections at 6 barg by means of nitrogen or air - and at the same time -
- Tightness check of the piping system with its components.  
All flanged and threaded connections are being checked by means of a "soap-test".
- Check of vessel name plate, stamping the name plate.

### 12.3.3 Inspection during modifications

The Inspection Agency will check/inspect all DME containing parts on compliance with the regulations.

The inspection comprises:

- Modifications of the vessel and piping system requiring welding such as relocation of the relief valve(s) to the rear of the vessel, replacing protruding welding neck flange nozzles by welded-in block flanges in case internally mounted bottom valves have to be installed, changing vessel connections to a location between the axles, removal respectively blinding-off the vapour return line, removal of drain connection, modification of the piping system.



- Welding methods and welders certification have to be approved by the Inspection Agency.
- Welding-in of plates and/or block flanges into the vessel wall; the first root pass has to be grinded-out and will be dyepenetrant inspected. Completed welding may be x-rayed at random.
- Internal inspection of the vessel including inspection of welded-in plates (visual and x-ray).
- Hydrostatic pressure testing of the vessel and piping system.
- Tightness check of the vessel and piping system.
- Material of pump, filters and valves.
- Flanges in piping system of the welding neck type.
- Threaded connections only if equal or smaller than two inch.
- Capacity and set-pressure of relief valves.
- Level indication and protection against overfilling.
- Type and make of appurtenances and flexible hoses.
- Check of the emergency shut-down system (remote controlled operation of the valves and simultaneous stopping of the pump).
- Presence and performance of the drive-off alarm.

#### 12.4 Vehicle inspection

Independent of the above inspections of the DME installation, the carrier-vehicle shall be thoroughly inspected in all its technical aspects at least once a year. This shall not be done by the Inspection Agency for DME installations, but by an Agency authorised by the Ministry of Traffic.

### 13. Installation book

Truck drivers as well as truck owners shall keep a file with information and documents regarding each particular tank truck. These files shall be kept up-to-date and shall contain the documentation as described in Appendix XI: "Installation book for DME tank truck drivers and for truck owners".

## 14. List of literature

- [1] Regulations for LPG Service Stations and Road Tank Trucks in The Netherlands  
COMPRIMO report, September 1987
  
- [2] European Agreement concerning the international Carriage of Dangerous Goods by Road (ADR)  
1997 edition

