

Methane as a Motor Fuel

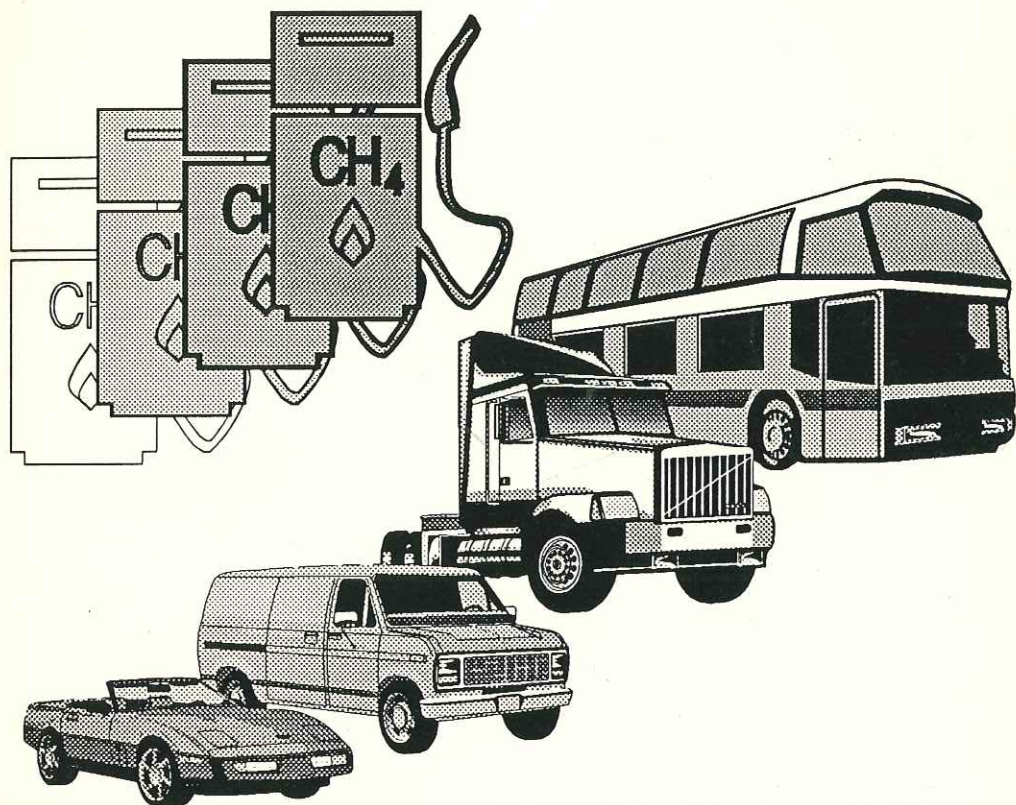

IEA

International
Energy
Agency

METHANE AS A MOTOR FUEL

Prepared for:

The International Energy Agency
Executive Committee on Alternative Motor Fuels
Annex VI

Prepared by

SYMPHER: MUELLER INTERNATIONAL INC.
Ottawa, Canada

In Association With:

ECOTRAFFIC AB
Stockholm, Sweden

May 1992

INTRODUCTORY REMARKS

The transportation sector of the countries that are members of the International Energy Agency (IEA) is still almost entirely dependent on petroleum. This for a long time has been a major concern to the Energy Ministers of the IEA. Recently, the quick conclusion of the Gulf War and the elimination of the cold war between east and west have relaxed energy security worries to some extent in the short term. However, these two incidents also highlight the volatile nature of world politics and therefore the risks to secure sources of energy

A growing matter of importance is the contribution of petroleum-based fuels, in the transportation sector, to a deterioration of air quality. Conventional transportation fuels are a major source of volatile organic compounds and oxides of nitrogen, carbon and sulphur. At the same time, there is a growing consensus that action needs to be taken to slow down the increase of greenhouse gases, including those coming from automobiles and trucks.

Thus, the potential replacement of conventional fuels with alternative transportation fuels can not only enhance the energy security of IEA countries, but at the same time may help their goals for an improved environment.

The IEA, through the Agreement on Alternative Motor Fuels, has recognized the need for an international forum for the exchange of technical, economic and environmental information about alternatives to conventional fuels. This information exchange will assist governments in forming the regulatory framework that addresses the environmental and energy challenges facing the IEA countries and the rest of the world. As part of this work, the IEA Executive Committee on Alternative Motor Fuels has produced this "State of the Art" review of the use of natural gas for vehicles (NGV) entitled "Methane as a Motor Fuel".

Dr. Pier-Paolo Garibaldi
Chairman, Executive Committee
IEA Alternative Motor Fuels Implementing Agreement

PREFACE

Methane, primarily from natural gas, is an abundant alternative source of energy for the transportation sector. As well, methane as a transportation fuel has the potential to improve air quality and reduce greenhouse gas emissions. This report, which addresses the potential of natural gas for vehicles (NGV), is a continuation of the Executive Committee's previous work dealing with alcohol fuels. This work included reports on the use of alcohols and alcohol blends as motor fuels, the production of alcohols, trends in motor fuels, and the use of alternative motor fuels in heavy duty engines.

Canada and Sweden are pleased to have acted as Operating Countries for the work in this report. It should also be noted that six countries contributed to the work involved in preparing the report: Canada, Finland, Italy, Japan, Sweden and the United States.

In addition to the copies of the report distributed to the participants, and those sent to IEA Headquarters, the Operating Country Representatives have a number of additional copies available upon request.

Bernie James
Alternative Energy Divisions, CANMET
Energy Mines and Resource Canada
Ottawa, Canada
(Operating Country Representative for Canada)

Gunnar Kinbom
Swedish Technical Union
Stockholm, Sweden
(Operating Country Representative for Sweden)

EXECUTIVE SUMMARY

The objective of this study was to provide the International Energy Agency with a "state-of-the-art" report regarding the current and potential future use of methane as a fuel for motor vehicles. In support of this overall objective, the study addressed the following topics:

- Worldwide reserves and availability of natural gas; gas extraction, processing and distribution systems; potential supplies of biogas, adaptability of the current situation to the transportation industry;
- Current technologies used for operating vehicles on compressed and liquefied natural gas, and future trends in engine and vehicle development;
- The economic and environmental consequences of expanding the use of methane as a vehicle fuel; and
- Technical and institutional barriers which could act against the expansion of natural gas in the road transportation sector.

The report provides conclusions regarding the current status of methane as a vehicle fuel, and recommendations for future policy, research work, and other activities directed at maximizing the benefits of methane as a vehicle fuel, and expanding its use on a world-wide basis.

Supply and Demand

Overall world reserves of natural gas are vast, and quite sufficient to accommodate any foreseeable growth in vehicle use over the next 25 years. Moreover, exploration activities are adding to the proven reserves at a rate greater than that at which the gas is currently being consumed. A high proportion of the total global reserve of gas is located in remote or inaccessible regions. However, gas from such regions could be moved to market by pipelines or liquefied natural gas transportation systems if the demand emerged. The generation of natural gas from waste products and sewage (biogas) is a proven technology which could be expanded to provide local supplies in urban areas.

Natural gas as extracted from a well is commonly 85 to 95% methane, with heavier hydrocarbon gases (ethane, propane, etc.) present, usually in diminishing proportions with increase in atomic weight. The primary contaminants are water vapour, carbon dioxide, nitrogen and hydrogen sulphide. Well-head gas must be processed to reduce the contaminants

before entering the pipeline distribution system. All countries using natural gas have established specifications governing the purity and composition of the processed gas delivered to consumers. The mix of hydrocarbons, the proportion of inert gases, and the amount of water and sulphur residue affect the heating value of the gas, and its tendency to corrode or damage distribution and storage systems. The composition and purity of well-head gas varies on an international basis, as do the specifications for processed gas. If natural gas is to be used as a fuel to reduce exhaust emissions from vehicles, purity and composition will have to be more closely controlled because of their effects on vehicle fuel cylinders and on the combustion processes in internal combustion engines.

Natural gas prices are related to crude oil prices, since both are primary sources of energy. The relationship is not direct, because natural gas is not so readily tradeable on an instantaneous basis. Large scale international natural gas movements are subject to long-term contracts. Distribution systems are frequently constructed to connect one exclusive supplier with one exclusive purchaser through a dedicated pipeline or liquefied natural gas (LNG) shipping system. Hence gas price changes tend to lag behind oil price changes. The link between gas and oil prices will continue into the future. A major study has predicted that future natural gas prices may be lower in Europe than in North America, which suggests that Europe will be a more favorable location for the development of natural gas vehicles.

Vehicle Fuelling

Natural gas is most often stored at high pressure (typically 20 MPa) in cylindrical tanks. This method is likely to remain predominant in the future. Vehicle fuelling therefore requires compression of the gas to force it into the storage cylinders. If refuelling time is to be comparable to normal liquid fuels, high capacity compressors and intermediate storage tanks are necessary. An alternative is to use a smaller compressor which progressively pressurizes the vehicle tanks over a period of several hours, without the need of intermediate "buffer" tanks. The two alternatives are logically termed "fast-fill" and "slow-fill". In both cases the vehicle fuelling system is considerably more complicated and costly than the traditional tank, pump and meter system for gasoline or diesel. The additional capital cost is accompanied by higher maintenance costs. In the case of "fast-fill" systems the cost of energy (normally electricity) to operate the compressor also becomes a significant factor in the overall economics of gas use.

Liquefied natural gas fuelling systems for vehicles have been developed, but very few are at present in actual use. They are also more complicated and costly than a system for gasoline or diesel because of the temperature

(-165°C) and pressure (typically 0.4 to 1.0 MPa) involved. The liquefied gas can be pumped into the vehicle at rates similar to gasoline or diesel, although the fuelling system must remain totally sealed and pressurized.

The high cost of building natural gas fuelling stations is a major factor retarding the establishment of a fuel supply network. Recently small individual compressors have become available, which can be attached to any domestic or industrial gas supply, and are capable of refuelling a car or light truck in approximately 6 hours. These devices are a relatively low-cost method for expanding the availability of natural gas for vehicle fuel use. They are now being marketed to the public in Europe, New Zealand and North America in increasing quantities. Natural gas for vehicles is also distributed in high pressure tank trailers. These are filled at a large central compressor station and driven to wherever fuel is required. The trailer may carry a small compressor for fuelling vehicles directly, or it may be connected to a permanent slow fill system at the refuelling station. This system can deliver fuel to any location, including those away from a main pipeline gas supply. This approach has become known as the "mother-daughter" or "satellite" supply system.

On-board Vehicle Storage

Natural gas fuel may be stored on-board a vehicle under compression in high pressure cylinders, as a liquid in insulated and pressurized cryogenic tanks, or adsorbed in special high-porosity materials contained in pressurized tanks.

None of these methods can provide the same energy storage density as gasoline or diesel. A vehicle using compressed natural gas needs to carry between 3 and 4 times the volume of fuel to achieve the same range as a similar gasoline or diesel vehicle. For liquefied gas, the ratio is approximately 1.5. Many converted vehicles have reduced driving range because it was not possible to provide so much extra space for fuel tanks. Vehicle weight may also be increased, because steel high pressure cylinders are much heavier than tanks for gasoline or diesel. However, new types of lightweight high pressure cylinders can be used to minimize any weight increase. The volume and weight problem is most acute for high pressure storage. Liquefied natural gas provides storage weight and volume figures much closer to petroleum fuels. This is the main reason for investigating LNG use in vehicles. However the problems associated with production, storage and distribution on a widespread scale make it unlikely that liquefied natural gas will be feasible for private vehicle or general fleet use. LNG is most likely to be used for buses and heavy trucks refuelling from central points.

The most common way of storing gas on-board vehicles is in cylinders pressurized to around 20 MPa. This method has been standard for many years and is likely to continue as such in the foreseeable future. Steel cylinders are widely used at present, but are being supplanted by new types which are very much lighter in weight. One design, termed "wrapped", uses a thin steel or aluminium alloy liner, which is reinforced by winding with glass filament bound by resin. The liner and wrapping share the stress load. Another design substitutes impervious polymer for the metal in the liner. This is often referred to as "composite" construction. In this case, all the stress is taken up by the wrapping.

If the volume required for pressurized storage is to be reduced the storage pressure must be increased. Higher pressure requires stronger, and therefore heavier and more costly, cylinders. It also causes a steep rise in compression work, with correspondingly higher energy costs. For these reasons the standard storage pressure will probably remain around 20 MPa in most countries, although original equipment manufacturers (OEMs) of vehicles in the United States are advocating 24 MPa as a means to increase vehicle range. Composite construction cylinders can provide more efficient use of the space available on a vehicle because they can easily be made in a wider variety of shapes and sizes than steel or hybrid cylinders.

Some countries have not yet approved the new lightweight cylinders for use in vehicles. A task force has been established in order to produce an international standard governing the performance and safety requirements for natural gas cylinders for vehicles.

Adsorptive storage, which uses pressures between 3 and 6 MPa, gives an energy density somewhere between that of compressed and liquefied gas. Several different materials and techniques have been investigated over the last 15 years, and a consortium of European and American companies is currently engaged in further research. It is unlikely that this technique will become practical in the foreseeable future. Disadvantages include sensitivity of adsorption and desorption to temperature, and progressive loss of storage capacity due to adsorptive material contamination.

Natural Gas Vehicles

About 700 thousand natural gas vehicles are in use world-wide. Most are cars, vans and light trucks which have been converted from gasoline fuel. A high proportion are "bi-fuel" conversions, which can be switched between gasoline and natural gas at will. The largest populations of vehicles are in Italy and the former Soviet states. New Zealand, Argentina, Canada and the U.S.A. each have large numbers of natural gas vehicles in operation. On a world-wide basis nearly all vehicle conversions have been carried out because natural gas is less expensive than gasoline. Economic considerations

continue to be the primary reason for conversion, but natural gas fuelling is increasingly seen as a way to reduce vehicle emissions. This has led to an upsurge in research activity, dealing with both the conversion of existing engines, and the production of engines optimized to run exclusively on natural gas.

The traditional bi-fuel conversion kit does not provide for full exploitation of all the advantages natural gas can offer as an internal combustion engine fuel. Disadvantages include approximately 10% to 15% loss of maximum power, reduced fuel efficiency and less than ideal emissions performance. However, the technology of converting existing gasoline engines to natural gas has made major advances in the last 4 to 5 years. Modern conversions are capable of interfacing with electronic engine control systems to provide advanced spark timing for the slower-burning gas. Gas carburetors or mixers are being abandoned in favour of injection systems, similar in concept to those used in modern gasoline engines. These provide more precise fuel control, leading to improved performance, fuel economy, and reductions in emissions. They can be applied to both converted bi-fuel natural gas/gasoline engines and engines designed for natural gas alone.

An engine which is designed specifically to operate on natural gas can give equal power and performance to a gasoline engine, with better fuel efficiency, and advantages in exhaust emissions levels. A natural gas engine can operate at a leaner fuel/air ratio than a gasoline engine. Spark timing must be advanced, and a higher compression ratio may be used. Engine weight and size need not be changed, and the manufacturing cost should be similar. Several organizations have tested engines optimized for natural gas fuel, but "real world" testing has been limited. These engines cannot run on gasoline, and it is therefore not reasonable to offer them for sale until natural gas fuel is much more widely available.

The use of catalytic converters with natural gas engines is also under intensive study. Topics receiving attention include ideal converter size, location and catalyst formulation. Modern conversion kits are fully compatible with the catalytic converters used on current gasoline vehicles. For dedicated engines, three-way or oxidizing converters may be used, depending on the engine combustion system and control strategies.

Diesel engines converted to run on natural gas are much less common than gasoline engines, the estimated number being no more than 1,000 worldwide. It is not practical to ignite natural gas by compression heat alone. One method of conversion uses a gas-air mixer or low pressure injection system in the inlet manifold, and a spark ignition system, effectively converting the diesel engine to Otto cycle operation. The diesel fuel injection system is no longer required and the engine operates only on natural gas. A second method of conversion retains the diesel system to inject a small amount of

diesel oil to start the gas charge burning. This is called a pilot injection or "dual-fuel" engine. Usually the engine idles on diesel alone, while at full load about 10% of the fuel is diesel and 90% is natural gas. Dual-fuel engines do not provide the best emissions levels, because diesel particulates are still present. The advantage is that the engine can still run on diesel in the event of gas supply interruption. Conversion to a spark ignition system is essentially irreversible. The spark ignited engine produces very low levels of particulates, and only requires one fuel system, but the spark plugs need to be changed periodically.

High pressure gas injection, similar to diesel injection, has been successfully tested in laboratory engines. The gas is injected directly into the cylinder and fired by spark plugs or pilot injection. One manufacturer retains hot exhaust gas in the cylinder to provide enough heat to ignite the natural gas charge. These techniques provide important pointers to the future of diesel to natural gas conversions, but have not yet been proved in working vehicles.

Optimized light and heavy duty natural gas engines may become very similar in design principles in the immediate future, using high precision feedback control gas injection systems with spark ignition. Two combustion strategies are receiving most attention at present. The first approach uses stoichiometric combustion and controls emissions with a three-way catalyst and oxygen sensor. Exhaust Gas Recirculation (EGR) may be used as an additional control measure for oxides of nitrogen (NOx). The other approach, lean-burn combustion, exploits the ability of natural gas to burn at very lean air/fuel ratios, which provides an inherent reduction in oxides of nitrogen emissions. Carbon monoxide and hydrocarbons are cleaned up with an oxidizing catalyst. The lean-burn strategy can be the more fuel efficient of the two types, but at the expense of some loss in maximum power. Stoichiometric combustion relies on advanced exhaust oxygen sensors and feedback control systems. These are currently expensive, but expected to fall in price with the general advance in microprocessor technology. At present, neither system shows conclusive superiority.

Emissions

Natural gas vehicles are expected to provide important reductions in emissions levels. The maximum advantages will only be obtained from engines dedicated to natural gas fuel, which have combustion chamber configurations, air/fuel mixing systems, ignition curves and other engine parameters optimized for natural gas combustion. Bi-fuel engines using after-market conversion kits do not represent the best that can be achieved in emissions reductions, although the latest generation kits using gaseous injection, electronic controls, and catalytic converters, are highly effective in emissions control when properly installed and adjusted.

In general, natural gas fuelled engines emit less carbon monoxide than either diesel or gasoline engines. Particulate levels are negligible, which is an important advantage in comparison to diesel. NO_x emissions are generally lower than those from diesel engines, and approximately equal to those from gasoline engines. Ultimate comparison depends on the success of particular engine design and combustion strategies. The question of hydrocarbon emissions is complicated by debate about the relative harmful effects of various hydrocarbons. Natural gas engines emit unburned methane gas, which would ordinarily count as a hydrocarbon emission. However, several authorities hold that methane is not environmentally as harmful, based on its photochemical reactivity, as other heavy hydrocarbons. This has led to non-methane hydrocarbon (NMHC) emissions standards, which exclude methane from the hydrocarbon count. Natural gas engines give lower NMHC emissions than gasoline or diesel engines. These lower NMHC emissions result in less ozone formation.

One area in which natural gas is clearly superior is evaporative emissions, which are normally entirely prevented by the totally sealed fuel system. Any gas which escapes is primarily methane, which is not of concern when compared to the benzenes and toluenes etc. in gasoline vapours.

Relative to gasoline and diesel, natural gas vehicles promise lower carbon dioxide emissions which are one of the principal greenhouse gases. However, when examining the greenhouse effect of transportation fuels, it is important to account for all the principal greenhouse gases from fuel extraction through to combustion in the vehicle. When the full effect of all the principal greenhouse gases are included, then the benefits of reduced carbon dioxide are somewhat offset by methane and nitrous oxide. Although there is a great deal of scientific uncertainty in the warming potential of the emissions over the fuel cycle, it appears that natural gas has somewhat lower impact on global warming than gasoline, but has about the same impact as diesel fuel.

Safety and Health

Natural gas as a vehicle fuel compares very favorably with gasoline and diesel from a safety point of view. Any leaks rapidly disperse into the atmosphere, because methane is lighter than air. Although the flammability limits in air are wider than gasoline or diesel, the required ignition energy is higher, so that the overall fire risk is comparable. Natural gas cannot be imbibed or absorbed through the skin. Because it disperses rapidly, methane is unlikely to build up ground level concentrations sufficient to cause dizziness or asphyxiation. Most of the concern over using natural gas in vehicles centers around the integrity of the high pressure storage system. Given the number of natural gas vehicles in service and their locations, detailed data on accidents is limited. However, there is no indication that natural gas vehicles are more prone than other vehicles to fires or accidents of any kind.

Extensive and rigorous laboratory testing programs, backed up by records of accidents involving fire or major collision damage, indicate catastrophic cylinder failure is an extremely remote possibility. Safety standards demand cylinders which remain in one piece when they burst, as opposed to exploding into pieces.

The natural gas extraction and processing industry has an impressive safety record. Statistics show that pipeline transport of gas is safer than truck or rail transportation of liquid fuels.

There is a need for more study of natural gas safety when used in vehicles, because existing standards and codes can sometimes inhibit vehicle development work through ambiguity, incompatibility, or unnecessary restrictions. The current work concerning gas storage cylinders may act as a precedent for the formulation of other standards pertaining to natural gas vehicle safety.

Economics of NGVs

The economic feasibility of NGVs is dependent on a number of key factors including:

- Incremental cost of vehicle, either conversion or purchase from the manufacturer;
- Price of natural gas in relation to gasoline or diesel;
- Annual fuel consumption of the vehicle; and
- Type of fuelling station used.

Each potential application must be analyzed on an individual basis. However, it is possible to make some general conclusions about the economic feasibility of NGVs.

Natural gas does not appear to be economically viable as a fuel for passenger cars, unless there are substantial fuel cost savings through preferential taxation. The economic viability would improve significantly if natural gas passenger cars were built on the production line by original equipment manufacturers (OEMs), giving a lower incremental vehicle cost than for an after-market conversion. For many IEA countries, the use of natural gas in passenger cars appears to be economic if the price of natural gas delivered to the fuelling station is below US\$0.12 per cubic metre (US\$3.30 per Gigajoule). The best candidates for conversion are cars with high annual fuel consumption, for example fleet vehicles, taxis and rental cars.

In heavy duty applications natural gas appears to be economically attractive for urban bus fleets, especially if overnight slow-fill fuelling is possible, and truck fleets that have access to either slow-fill or public fuelling stations. As the cost of diesel operations rises, due to factors such as low sulphur diesel fuel, particulate traps, and other increased costs to meet new emissions regulations, the potential for natural gas market penetration will increase. The use of liquefied natural gas could reduce the concerns of vehicle operators regarding extra weight and loss of range.

Strategies for Further Implementation

The use of methane as a vehicle fuel can be economically viable for vehicle fleets, particularly those operating in urban areas. From a global perspective the introduction of methane fuelled vehicles is especially attractive for countries having their own gas reserves, as a method of reducing national dependency on petroleum imports. The U.S.A., Canada, Sweden and many European countries are looking to natural gas as one way to reduce atmospheric pollution from vehicle exhaust.

Major barriers hindering the advancement of methane as a vehicle fuel include limited operating range, scarcity of fuelling stations and service support, non-availability of production line vehicles from recognized manufacturers, variations in fuel gas composition, and inconsistency of applicable regulations.

The nature and scale of the societal and industrial change required to bring significant numbers of NGVs into service means that continuation of government support and assistance is essential. Several forms of subsidy have been employed in the past, including preferential fuel taxation, conversion cost rebates, and government vehicle fleet purchases. The exact nature of support required is dependent upon national circumstances. Support for expansion of fuel supply networks is particularly necessary because of the high levels of capital investment involved.

There is a need for an extension of existing research work concerning engine and vehicle technology. The primary concern is to produce engines and vehicles which are specifically designed to operate on natural gas. This will avoid the compromises which have to be made in conversions of existing gasoline or diesel vehicles. Other topics of importance are:

- Effects of natural gas composition on engine performance and exhaust emissions;
- Use of biogas as a vehicle fuel;
- Engine control and fuel/air mixing systems;

- Combustion strategies and combustion chamber design;
- Catalytic control of exhaust emissions; and
- Lightweight fuel storage cylinders.

It is vital to encourage the fullest participation of vehicle original equipment manufacturers in the development of optimized engines and vehicles. They have the expertise and resources required for the tasks to be undertaken. Perhaps more importantly, they can provide a degree of credibility to the NGV concept which can never be achieved by after-market conversions. However, the manufacturers need to be convinced that there is a market for new products in order to invest resources. At the same time the continuing importance of after-market bi-fuel conversions, as a way of solving the classic "chicken and egg" vehicle population versus infrastructure dilemma, cannot be neglected. A closely related activity is the creation of educational and training programs for NGV servicing and maintenance. Governments may encourage NGV activity by co-operating in the standardization of safety codes and emissions regulations. This will lessen the burden of having to produce engines and conversion equipment to several different specifications, with consequent increases in unit cost.

More research into emissions is needed in order to clearly quantify any environmental benefits to be realized from the increased spread of NGVs. Although NGVs are expected to provide environmental benefits there are still many questions to be answered, such as the effect of methane emissions on ozone formation and global warming.

Storing methane in a liquefied form can allow a vehicle operating range close to gasoline or diesel levels without unacceptable increases in fuel tank size or weight. Very little work has been done on the development of LNG vehicles. Widespread general use of LNG may be impractical because of the complications involved in manufacture, distribution and storage. However, liquefied storage has advantages for vehicles regularly drawing large quantities of fuel from central locations, such as transit buses and local truck fleets. Further work on LNG powered heavy vehicles should definitely be encouraged. LNG is also particularly attractive as a fuel in countries which import much of their gas supply in the liquid state. Japan is a prominent example.

GLOSSARY OF TERMS

Abbreviations

C ₂ H ₆	Ethane
C ₃ H ₈	Propane
C ₄ H ₁₀	Butane
CAA	Clean Air Act
CARB	California Air Resources Board
CF	Cubic Foot
CFC	Chloro Fluoro Carbon
CH ₄	Methane
CM	Cubic Metre
CNG	Compressed Natural Gas
CO	Carbon Monoxide
CO ₂	Carbon Dioxide
ECE	Economic Commission for Europe
EPA	U.S. Environmental Protection Agency
FTP	Federal Test Procedures
HC	Hydrocarbon
HHV	Higher Heating Value
IANGV	International Association for Natural Gas Vehicles
LEV	Low Emission Vehicle
LHV	Lower Heating Value
LNG	Liquefied Natural Gas
NCV/GCV	Net/Gross Calorific Value
NG	Natural Gas
NGV	Natural Gas Vehicle
NMHC	Non-Methane Hydrocarbon
NMOG	Non-Methane Organic Gas
NO	Nitric Oxide
NO ₂	Nitrogen Dioxide
NO _x	Oxides of Nitrogen
OEM	Original Equipment Manufacturer
SI	Spark Ignition
THC	Total Hydrocarbon
TWC	Three Way Catalyst
ULEV	Ultra Low Emission Vehicle
VOC	Volatile Organic Compound
ZEV	Zero Emission Vehicle

Multiples

k	kilo (10^3)
M	mega (10^6)
G	giga (10^9)
T	tera (10^{12})
P	peta (10^{15})

TABLE OF CONTENTS

<i>Section</i>	<i>Page</i>
Introductory Remarks	
Preface	
Executive Summary	i
Glossary of Terms.....	xi
I Introduction	1
A. Background.....	1
B. Objective	2
C. Scope and Methodology.....	3
II Natural Gas And Biogas Supply And Properties	5
A. Natural Gas Reserves.....	5
B. Natural Gas Properties.....	12
C. Natural Gas Processing.....	16
D. Delivery Systems	19
E. Liquid Natural Gas and Gas Pricing	20
F. Biogas Supplies.....	22
G. Summary	27
III Vehicle Fuelling Technology.....	30
A. Compressed Natural Gas.....	30
B. Liquefied Natural Gas.....	36
C. Summary	39
IV On Board Vehicle Storage.....	41
A. Current Technology.....	41
B. Standards and Codes	47
C. Future Technology	48
D. Summary	49

TABLE OF CONTENTS (continued)

<i>Section</i>	<i>Page</i>
V Light Duty Vehicle Utilization	51
A. Current Vehicles and Technology	51
B. Future Technology	68
C. Summary	75
VI Heavy Duty Vehicle Utilization.....	77
A. Current Vehicles and Technology	77
B. Future Technology	89
C. Summary	92
VII Emissions.....	94
A. Environmental and Health Issues.....	94
B. Regulatory Response	97
C. Exhaust Emissions - Overview	103
D. Exhaust Emissions From Light Duty Vehicles	107
E. Exhaust Emissions From Heavy Duty Vehicles.....	112
F. Potential Exhaust Emissions With Future Technology.....	119
G. Evaporative and Refuelling Emissions.....	122
H. Emissions During Fuel Extraction, Processing And Distribution	122
I. Greenhouse Gas Emissions.....	124
J. Biogas Emissions.....	127
K. Noise	128
L. Summary	129
VIII Health And Safety Considerations.....	132
A. Health And Safety Overview	132
B. Safety Issues - Motor Vehicle Operation.....	136
C. Regulatory Response.....	141
D. Extraction, Processing And Distribution	142
E. Summary	144

TABLE OF CONTENTS (continued)

<i>Section</i>	<i>Page</i>
IX	The Economics of Methane As A Motor Fuel 145 <ul style="list-style-type: none"> A. Introduction 145 B. Review of Literature..... 146 C. Analysis..... 154 D. Summary 163
X	Strategies For Further Implementation 165 <ul style="list-style-type: none"> A. Strategic Considerations 165 B. Barriers To Implementation..... 165 C. Strategies For Further Development And Implementation 166
Exhibits	
I-1	Energy Content of Fuels 3
II-1	Natural Gas Total and Exportable Reserves (Jensen)..... 7
II-2	Regional Reserves of Natural Gas (Jensen) 8
II-3	Variations in Natural Gas Composition - Canada and Selected European Sources..... 12
II-4	Natural Gas Composition in U.S. Cities..... 13
II-5	Natural Gas Composition in Australian Cities 13
II-6	Natural Gas Classifications (U.S.A.)..... 14
II-7	Combustion Properties of Gases 15
II-8	Wobbe Index Numbers for Natural Gas Constituents..... 16
II-9	Flow Diagram of Natural Gas Processing 17
II-10	Flow Diagram of the Amine Process for Gas Sweetening 18
II-11	Changes in Natural Gas Properties with Processing..... 19
II-12	Projected Natural Gas Prices (Jensen) 22
II-13	Biogas Energy Potential from Organic Waste in Sweden (TWH/year)..... 23
II-14	Continuous Feed Biogas Digester 24
II-15	Costs for Biogas Production 27
III-1	Slow Fill Fuelling System 31
III-2	Home Refuelling Appliance 32
III-3	Fast Fill Fuelling System 33
III-4	Electronically Controlled CNG Fuelling Station..... 34
III-5	Vehicle Fuelling Time/Cost Relationship..... 36

Exhibits (continued)

IV-1	Comparative Weights of Storage Cylinders.....	44
IV-2	Current and Future Cylinder Price Relationships.....	45
IV-3	Liquefied Natural Gas Storage Tank	46
V-1	Major World NGV Populations.....	52
V-2	Natural Gas Vehicles in Argentina.....	55
V-3	Natural Gas Vehicles in Canada.....	58
V-4	Schematic of Gasoline Engine Conversion Kit	61
V-5	Schematic of IMPCO Electronic Control Natural Gas Conversion Kit.....	69
V-6	Schematic of the ORTECH "GFI" Gas Injection System.....	72
VI-1	International Distribution of Heavy Duty Natural Gas Vehicles	77
VI-2	Schematic of Caterpillar Stoichiometric Combustion Engine	83
VI-3	Heavy-Duty Natural Gas Engine Thermal Efficiencies.....	89
VII-1	Commonly Used Emissions Test Cycles.....	98
VII-2	Comparison of Passenger Car Emission Standards Under the U.S. Clean Air Act (Tier 1)	100
VII-3	Comparison of Heavy Duty Diesel Engine Emission Standards Under the U.S. Clean Air Act (Tier 1).....	100
VII-4	Passenger Car Emissions Standards Under the California Plan (g/mile).....	101
VII-5	Proposed Fleet Weighted Average NMOG Standard.....	102
VII-6	Emissions Trends as a Function of Air-Fuel Ratio	103
VII-7	Emissions from Light Duty Natural Gas/Gasoline Bi-Fuel Vehicles.....	108
VII-8	Comparative Emissions From 1990 Ford Taurus Cars Operating on Natural Gas and Gasoline	109
VII-9	Dedicated LDV Emissions Results	111
VII-10	Emissions from Diesel-Pilot Ignited Natural Gas Engines	114
VII-11	Emissions from Stoichiometric Natural Gas Powered Heavy Duty Engines	115
VII-12	Emissions From Stoichiometric Natural Gas Powered Heavy Duty Engines Tested Over ECE R49.....	117
VII-13	Emission from Lean Burn Natural Gas Engines	118
VII-14	Fuel Cycle.....	123
VII-15	Efficiency For a Natural Gas Fuel Cycle	123
VII-16	Emissions During the Natural Gas Fuel Cycle	124
VII-17	Relative Global Warming Potential (GWP)	125
VII-18	Summary of CO ₂ For The Fuel Cycle.....	126
VII-19	Warming Potential For The Fuel Cycle.....	127
VII-20	Efficiency for the Biogas Fuel Cycle.....	128

Exhibits (continued)

VII-21	Summary of Interior Noise Levels for a Natural Gas Powered Vehicle	129
VII-22	Summary of Emissions Benefits With NGV's.....	130
VIII-1	Selected Physical and Chemical Properties of Natural Gas, Gasoline and Diesel	133
VIII-2	Flammability Envelope of Natural Gas As a Function of Mass of Gas.....	134
VIII-3	Comparative Toxicity Ratings	136
VIII-4	Natural Gas Accident Data-U.S. Experience.....	139
VIII-5	Occupational Hazards of Energy Production.....	143
VIII-6	Relative Hazard Ranking of Various Transport Modes.....	143
IX-1	Lifetime Fuel Savings From Natural Gas Conversion	147
IX-2	Gasoline and CNG Energy Equivalent Price Comparison (U.S. Dollars and Gasoline Litre Equivalent).....	150
IX-3	Heavy Duty Vehicle Fuel Cost Comparison	152
IX-4	World Bank Economic Model Assumptions.....	153
IX-5	World Bank Analysis: Break-Even Crude Oil Price (US\$/bbl) with a Gas Price of US\$1/GJ	154
IX-6	Passenger Car Application: Current Technology	156
IX-7	NPV of NGV in Passenger Cars (including Fuel Taxes).....	157
IX-8	Fleet Application - OEM Technology.....	159
IX-9	Summary of Delivered Gas Prices For Breakeven.....	159
IX-10	Urban Bus Application: Fast-Fill.....	161
IX-11	NPV of NGV in Urban Buses (including Fuel Taxes).....	162
IX-12	Summary of Delivered Gas Prices for Breakeven: Heavy Duty Vehicle Applications	163

I INTRODUCTION

A. BACKGROUND

Natural gas and other sources of methane have been used as a fuel for vehicles since the 1920s. The first country to develop a sizeable permanent market for natural gas vehicles (NGVs) and associated technology was Italy. It has had between 100,000 and 250,000 natural gas vehicles in operation since 1950. Italy still has the largest population of NGVs in the world. In the 1970s, New Zealand took the lead in development and by 1985 had over 125,000 NGVs on its roads. During the 1980s, Canada, Australia, Scandinavia, Argentina, and the U.S.A. encouraged the exploitation of natural gas as a fuel, and began to put substantial numbers of vehicles into service. The former Soviet Union also has a long established natural gas vehicle program in place, and reports over 300,000 vehicles currently operating. Close to one million vehicles worldwide now use natural gas as a fuel.

Natural gas has traditionally been used as a low price substitute for gasoline. Countries seeking to reduce dependence on imported oil have been most active in promoting methane as a vehicle fuel, particularly those having their own reserves of natural gas. In many instances natural gas used in vehicles has received favorable tax treatment in comparison to gasoline and diesel in order to encourage its use.

In the last ten years natural gas fuelling has also achieved prominence as a method for cutting emissions from motor vehicles, especially ozone forming gases, particulates and toxins. Increasing emphasis is being placed on this aspect.

Despite the economic incentives, a number of limitations, such as restricted range and lack of fuelling infrastructure, have often prevented natural gas vehicles from making major penetrations into the vehicle market. Original equipment manufacturers (OEMs) have until very recently not produced natural gas vehicles; instead owners have had their vehicles converted by a third party after purchase. Some U.S. manufacturers are now planning to offer, at extra cost, factory built vehicles with full warranty and service support. Production vehicles equipped from the outset for natural gas are more attractive to prospective purchasers. The market penetration of natural gas vehicles would be greatly aided if they were produced and advertised on an equal basis with gasoline vehicles. The introduction of low cost individual refuelling appliances which can be attached to an ordinary domestic gas supply is helping to solve the problem of limited availability of fuel.

About 700,000 vehicles worldwide currently operate on natural gas. Over 95% of these are passenger cars, and light trucks and vans, with converted gasoline engines. The proportion of heavy-duty vehicles is very small at present but is expected to grow substantially in the near to medium term future. Nearly all of the leading diesel engine manufacturers have built natural gas truck or bus engines, and some designs have achieved semi-production status. Several of the world's most prominent engine research institutions are engaged in large-scale programs investigating all aspects of engine performance and emissions reduction. In many countries governments and industry are jointly sponsoring fleet trials and development projects.

Since the late 1980s, when the emissions reduction potential of NGVs came to the forefront, international interest in natural gas vehicles has reached an all time high. The stage is definitely set for major advances in the acceptance of natural gas as an alternative to gasoline and diesel, and rapid growth in the numbers of vehicles using it as fuel.

B. OBJECTIVE

The objective of this report was to provide information to government bodies in IEA participating countries about the existing and future value of methane, in the form of natural gas and biogas generated from waste materials, as a fuel for motor vehicles. The specific topics addressed included:

- Natural gas availability, the transportation and distribution infrastructure, and its adaptability to the the needs of private and commercial vehicle users;
- Current and future natural gas engine and vehicle technology;
- The economic and environmental consequences of the large scale introduction of natural gas as a vehicle fuel; and
- Technical and institutional barriers to the advancement of natural gas as a vehicle fuel.

The report was intended to present the information in such a manner that it would be used as a basis for decisions regarding the feasibility of starting, or extending existing, programs promoting the use of natural gas vehicles in countries participating in the IEA agreement on alternative motor fuels. Conclusions regarding the current and future status of natural gas as a vehicle fuel, and recommendations for the most advantageous exploitation of this energy resource in the future, are included.

C. SCOPE AND METHODOLOGY

The information in this report is derived from the collection and analysis of data regarding fleet trials, research and development activities, manufacturers' programs, and public and commercial use of natural gas as a vehicle fuel. The information was obtained from contacts in the NGV industry, published papers, conference presentations and the consultant's experience.

The report has been written with the intention of focussing primarily upon technical developments, and economic and political trends, relevant to the IEA participating countries, and likely to occur within the next five to seven years. Therefore, it should be possible to make decisions affecting at least that time period. Information about the NGV situation in non IEA countries is provided when relevant. The report disregards any possible technologies or trends unsupported by scientific evidence at the present time.

The following fuel properties have been assumed for purposes of analysis. The properties of gasoline and diesel generally remain within a fairly narrow range, but there can be quite wide variations in the composition and energy content of natural gas and biogas.

Exhibit I-1. Energy Content of Fuels

Fuel	Lower Calorific Value (LCV)		Higher Calorific Value (HCV)		Density
	MJ/l	MJ/kg	MJ/l	MJ/kg	
Gasoline	33	45	44	60	0.73
Diesel	36	43	43	51	0.84
	MJ/m ³	MJ/kg	MJ/m ³	MJ/kg	kg/m ³
Natural Gas	36	44	40	47	0.75

On the basis of Lower Calorific Values:

- 1 kg natural gas is equivalent to about: 1.33 l gasoline or 1.22 l diesel.
- 1 m³ natural gas is equivalent to about: 1.10 l gasoline or 1.00 l diesel.

Other conversion units used in this report include:

- $1 \text{ m}^3 = 35.3 \text{ ft}^3$
- $1 \text{ kWh} = 3.60 \text{ MJ}$
- $1 \text{ MPa} = 145 \text{ lb/in}^2$
- $1 \text{ kJ} = 0.948 \text{ Btu}$

II NATURAL GAS AND BIOGAS SUPPLY AND PROPERTIES

A. NATURAL GAS RESERVES

Natural gas is found in many of the regions of the world that contain reservoirs of crude oil, oil shale, tar sands or coal. The world supply of natural gas can be divided into three categories, based on the type of reservoir in which it is found.

- Non-associated gas is found in reservoirs containing no crude oil. This type of gas can be left in the ground until it is required for fuel production, and is therefore sometimes referred to as a discretionary source. Non-associated gas is the preferred feedstock for pipeline transfer.
- Associated gas is found in the same formation or reservoir as crude oil. It may be segregated as a "cap" over the oil, or it may be dissolved in the oil. Natural gas which occurs in associated reservoirs is often flared (burned off at the well head), instead of being processed and stored, if no economic market is available at the time the oil is being extracted.
- Condensate, which is a very light form of crude oil, containing only a fraction of the range of hydrocarbons normally found in crude oil. Condensate must be processed in order to yield natural gas.

The varied sources and methods of processing natural gas, as well as the expense of shipping a gaseous product over long distances, means that any discussion of supply must be tempered with consideration of accessibility to markets. For example, natural gas lends itself to a decentralized distribution system on a local scale (e.g. through home refuelling appliances). However, at a regional or international level, distribution is economic only on a very large scale (e.g. pipelines or liquefied natural gas (LNG) plants). Small inter-regional or international movements of natural gas are generally not feasible, since LNG plants and tankers and pipelines involve substantial fixed costs that require large volumes of gas to justify.

Some proven world reserves of natural gas are located in areas where there are no markets for it as a fuel, due to inadequate transportation facilities or uneconomic prices. Therefore there tends to be limited incentive to explore for further reserves. It has been postulated that substantial additional gas supplies would be found if more exploration took place.¹

¹ "Natural Gas Supply, Demand and Price" Report for the International Energy Agency, Jensen Associates Inc. Boston, Massachusetts. 1990.

Natural gas accounts for about 44% of the energy in the world's proven hydrocarbon reserves, but accounts for only 35% of the total hydrocarbon consumption. The two key factors to explain this divergence are the very high costs to transport natural gas as compared to crude oil, and the fact that many gas reserves were discovered as a by-product of crude oil exploration, rather than demand for the natural gas. Only 13% of the world's natural gas production leaves its country of origin, and natural gas accounts for only 14% of the international trade in hydrocarbons.²

The world continues to add to the proven reserves of natural gas faster than it is being consumed. However, much of the growth in reserves is occurring in locations such as Siberia and the Middle East, which are isolated from major gas markets, and may be inaccessible to potential LNG tanker routes or remote from existing pipeline infrastructure.

In a 1990 report for the International Energy Agency, Jensen Associates prepared a status list of the world reserves based on 6 market categories. The report estimated the total world proven gas reserves as of December 1988 to be 3,999 trillion cubic feet (Tcf) (113.2 trillion cubic metres) for all market categories.³ The market categories, and their estimated share of the total world reserves are:

Domestic Committed

Level of gas production within the country (or region) for domestic consumption, or set aside for future domestic consumption for next 20 years. This category represents 27% of the world's proven gas reserves.

Export Committed

Total amount of gas to be exported to foreign markets as committed by contract. This category represents 5% of the world's proven gas reserves.

Production Deferred

Includes reserves subject to exploitation of associated crude oil reservoirs, for which a market does not presently exist. This category represents 16% of the world's proven gas reserves.

Frontier Reserves

Includes high quality reserves in remote locations, which may in the future be served by pipeline. This category represents less than 1% of the world's proven gas reserves.

2 Ibid page 5.

3 Ibid page 5.

Marginal Surpluses

These supplies are surplus to domestic needs, but because of high transportation or production costs may not be economically viable for export sales. This category represents 9% of the world's proven gas reserves.

Exportable Surpluses

These reserves are otherwise not committed, and represent large reservoirs of gas with good accessibility to pipelines and markets. This category represents 43% of the world's proven gas reserves. Exportable surpluses rise as new discoveries of gas are made or as prices and technology change to make production viable. Exportable reserves may fall as commitments are made or domestic requirements change. Exhibit II-1 tracks the growth in exportable reserves from 1978 to 1988.

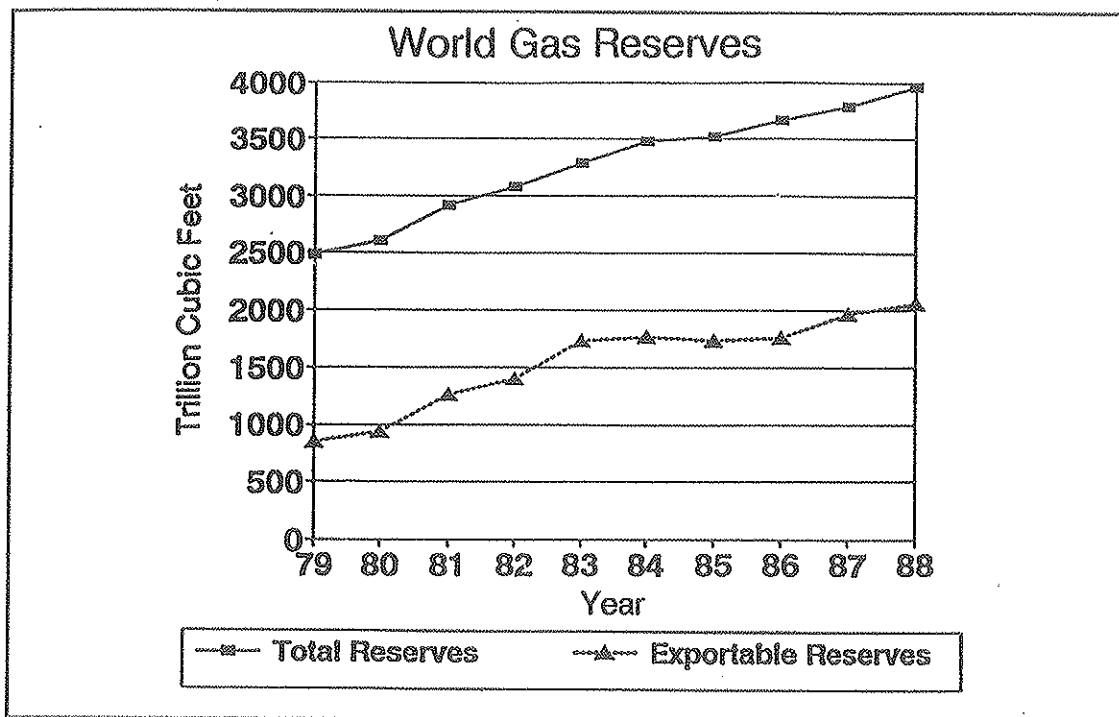
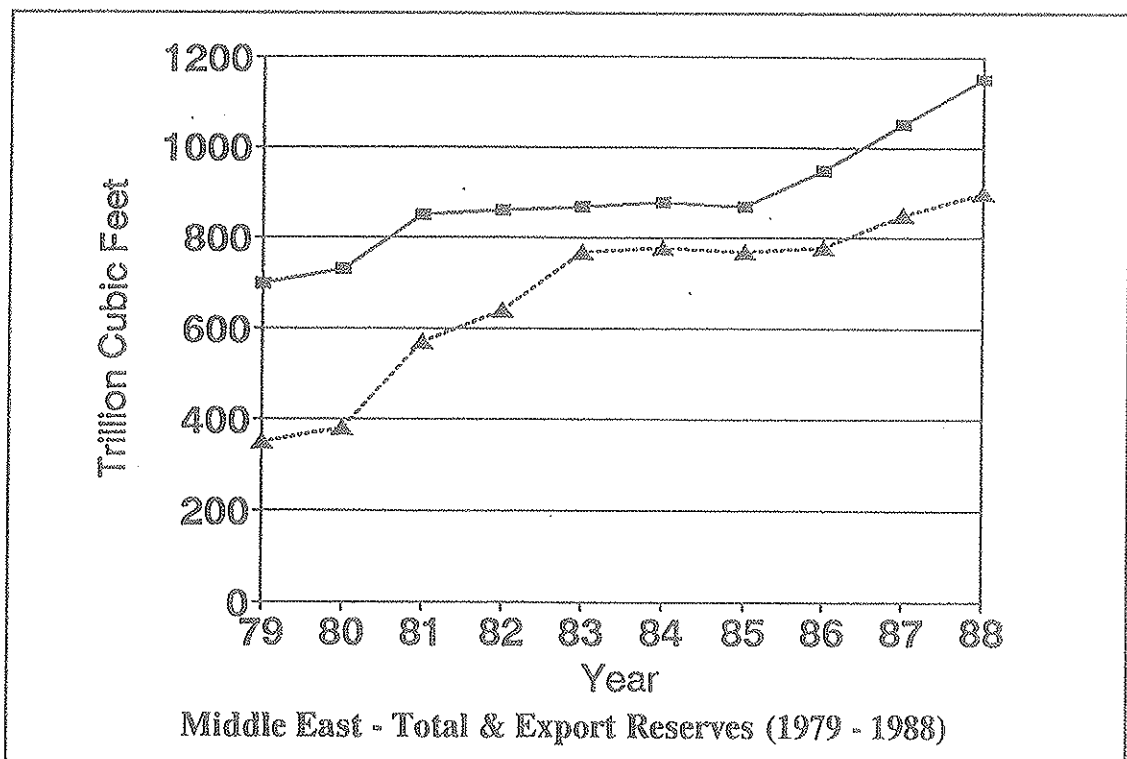
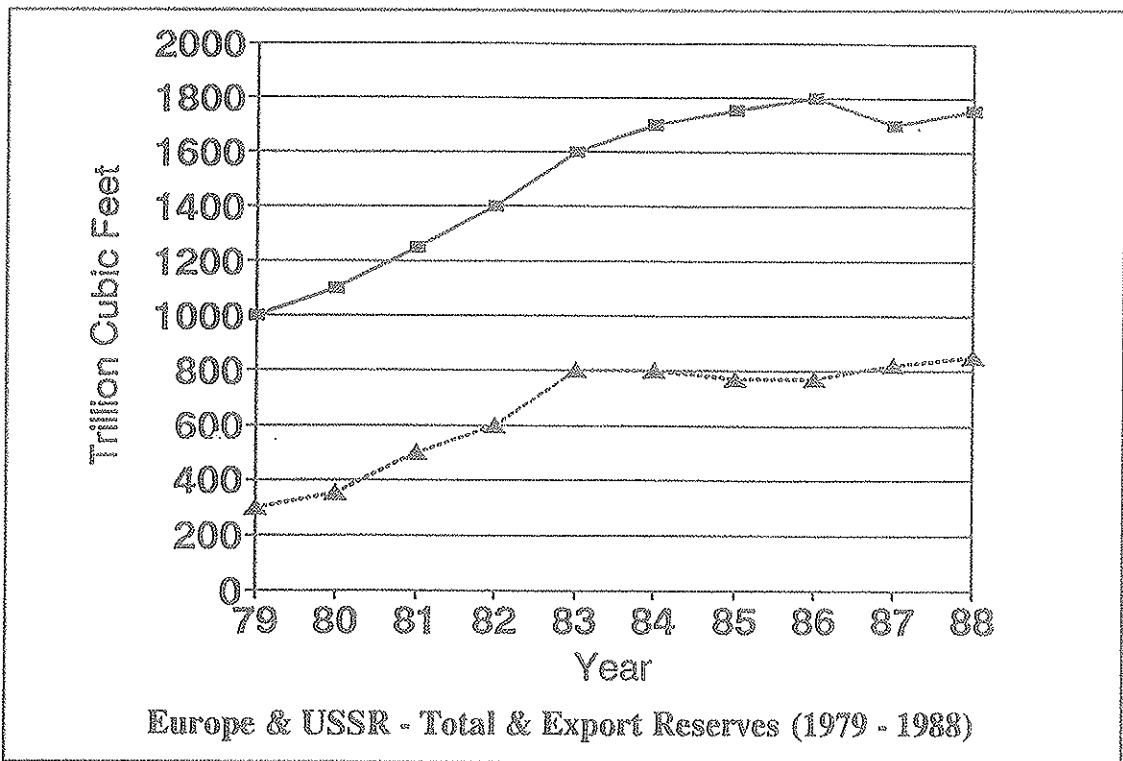

Exhibit II-1. Natural Gas Total and Exportable Reserves (Jensen)

Europe and the USSR

This region holds about 43% of world proven reserves of natural gas. The former Soviet Union alone holds 37% of the world reserves. Norway and the Netherlands also hold significant proven reserves. The Soviet reserves also account for about 48% of the world's exportable surplus of natural gas. These reserves are sufficient to justify LNG facilities for export, however the distance from tidewater may also have an impact on the economic viability of such exports. Land transport by pipeline is also a possibility for Soviet exports to Europe. Norway is the only other country considered to have sufficient reserves to justify the development of LNG export facilities.

Exhibit II-2 summarizes the supply of natural gas by region and market category as tracked by Jensen Associates. The situation in each region is discussed below.



—■— Total Reserves - - -▲- - - Exportable Reserves

Exhibit II-2. Regional Reserves of Natural Gas (Jensen)

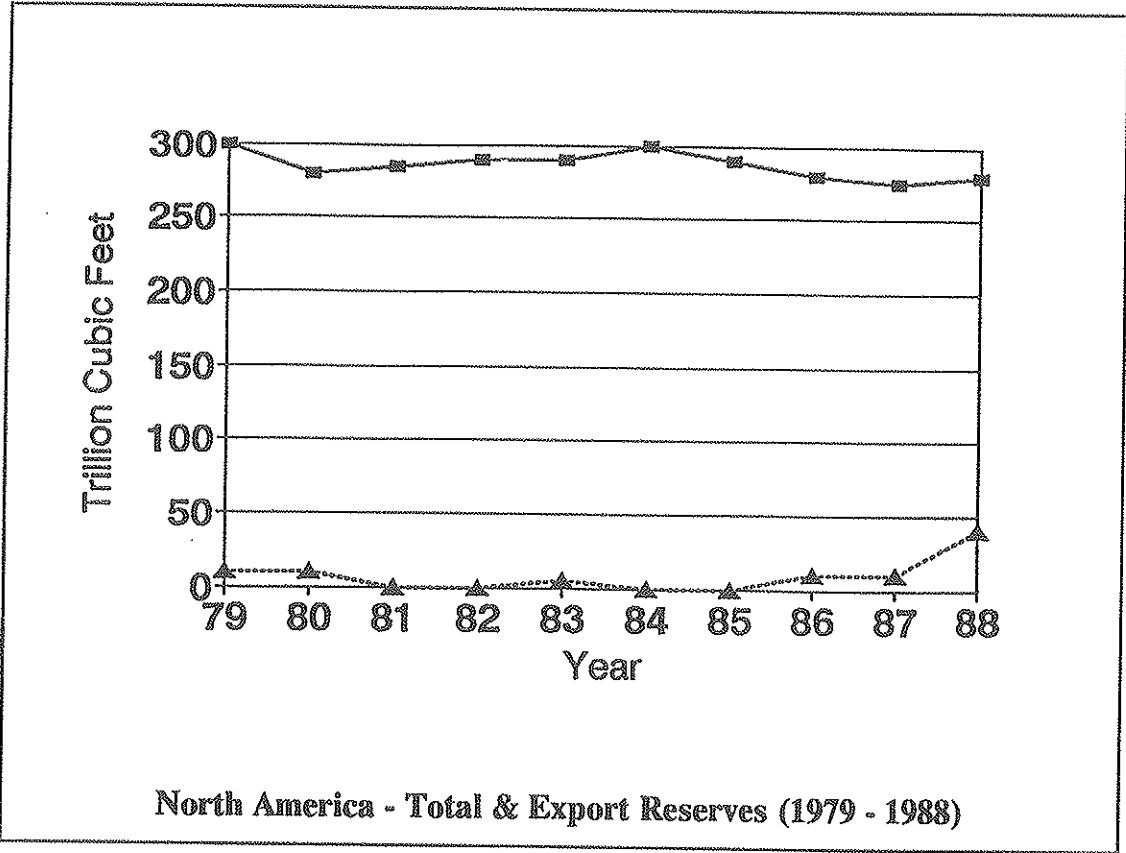
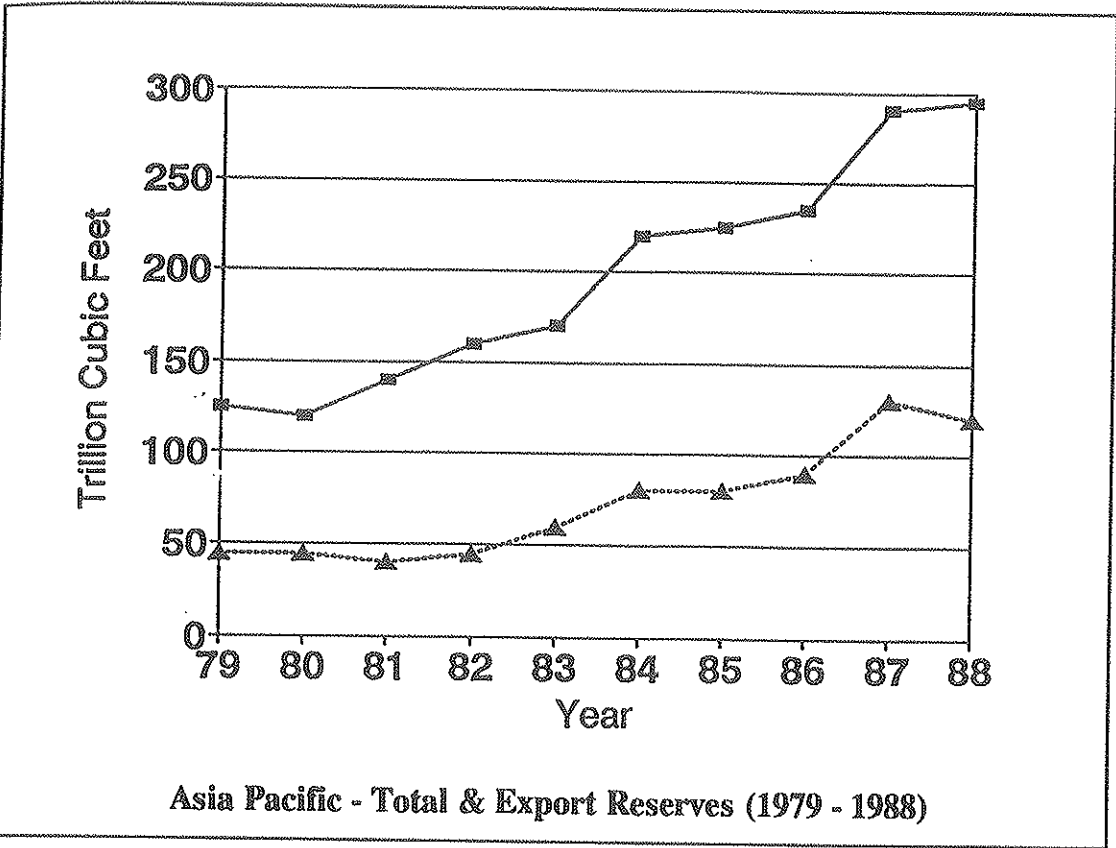

Total Reserves
 Exportable Reserves

Exhibit II-2. Regional Reserves of Natural Gas (Jensen) (Continued)

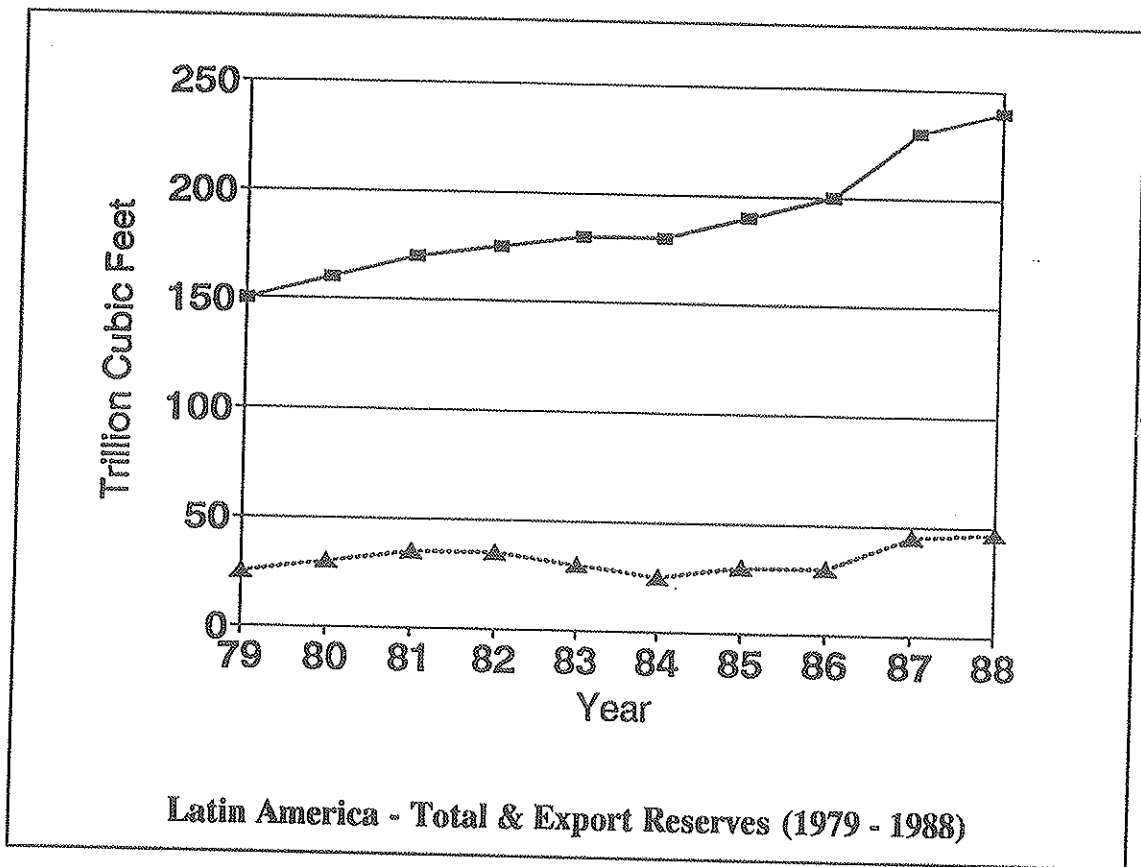
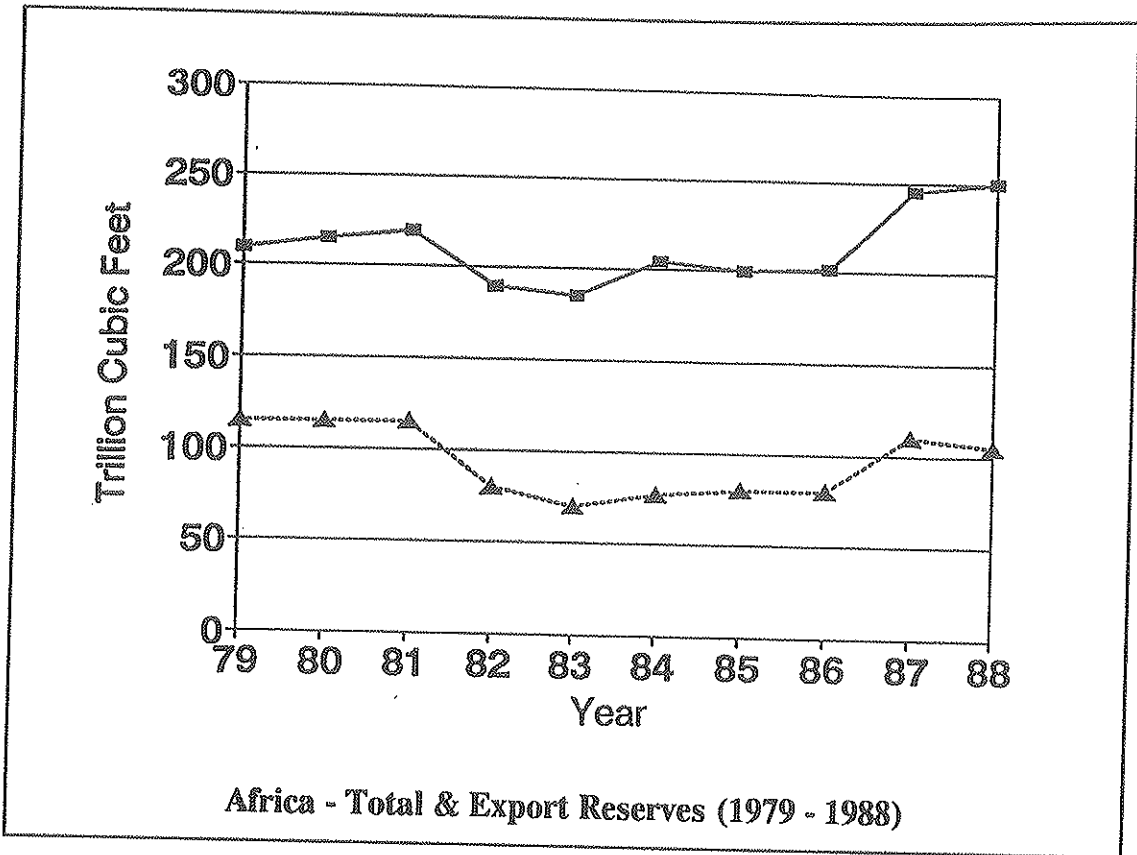

—■— Total Reserves - - - ▲ - - - Exportable Reserves

Exhibit II-2. Regional Reserves of Natural Gas (Jensen) (Continued)

The Middle East

The Middle East accounts for about 30% of proven world reserves. Iran, Abu Dhabi and Qatar hold about 71% of the total, and about 96% of the exportable, reserves in this region. This discrepancy arises because much of the gas in other countries is contained in associated reservoirs, which cannot be developed for production until the related crude oil deposits are marketed. Exploration is continuing and the total reserve of gas in the region is expected to continue to increase. Iran, Abu Dhabi and Qatar all have reserves sufficient to justify development of LNG export projects.

North America

The United States and Canada have proven reserves of approximately 286 Tcf (8Tcm), with a combined exportable surplus estimated at 40 Tcf (1Tcm). This is about 7% of total world proven reserves. Proven reserves in North America are being augmented at approximately the rate at which gas is being consumed. In Canada the exportable surplus is determined by estimating domestic requirements for the next twenty years, with volumes in excess of requirements becoming available for export sales. Additional reserves from unconventional sources such as tar sands, coal seams and geopressurized brines may significantly increase the total reserves available in Canada if price increases make recovery financially viable.

In the United States the proven domestic reserves are estimated to be 11 times the current annual consumption rate.⁴ The U.S. Department of Energy has estimated the total amount of natural gas, recoverable from all sources using existing technologies, to be 1,188 Tcf (34 Tcm), or in excess of 70 years supply.

Asia-Pacific

This region holds about 7% of proven world reserves. Australia, Malaysia and Indonesia account for about 70% of the reserves of the region, and are considered to have adequate reserves to support development of an LNG facility for the export of natural gas. In recent years the trend for all three of these countries has been to increase their total and exportable reserves.

Mexico and Latin America

Mexico, Venezuela, Argentina and Trinidad account for about 90% of the 240 Tcf (6.7 Tcm) of proven reserves in Latin America. Proven reserves in Venezuela have been growing rapidly in the last decade, while those of most other countries in the region have remained relatively constant or declined. Much of Mexico's reserve is in associated reservoirs, and actual production

⁴ "Alternative Motor Vehicle Fuels to Improve Air Quality, Options and Implications for California." California Council for Environmental and Economic Balance, Sacramento, 1990.

rate varies with oil prices and markets. The reserves in Venezuela and Trinidad are considered large enough to justify LNG export projects.

Africa

Africa holds about 6% of the world's proven natural gas reserves. Algeria and Nigeria together contain about 76% of the continent's proven reserves, with another 10% being held by Libya. Both total reserves and exportable reserves have fluctuated in the past decade, although they have generally been on an upward curve. Algeria and Nigeria are considered to have sufficient reserves to justify development of a LNG export facility.

B. NATURAL GAS PROPERTIES

Natural gas consists primarily of methane (CH₄), with small amounts of higher hydrocarbons such as ethane (C₂H₆) and butane (C₄H₁₀), and inert gases such as nitrogen (N₂) and carbon dioxide (CO₂). The exact composition varies widely on an international scale and may vary even from well to well in the same field. Exhibit II-3 shows the variation in composition between Canada and several European countries. Exhibit II-4 provides a sample of representative compositions of natural gas supplies in cities in the U.S.A. Exhibit II-5 gives the corresponding information for a number of Australian cities.

Exhibit II-3. Variations in Natural Gas Composition - Canada and Selected European Sources

Component vol %	Canada	Denmark N.Sea	Norway Troms	Germany	U.S.S.R.
Methane (CH ₄)	95.4	91.1	91.6	88.7	98.9
Ethane (C ₂ H ₆)	0.2	4.7	3.6	5.3	0.2
Propane (C ₃ H ₈)	0.2		0.4	1.6	0.0
Butane (C ₄ H ₁₀)					
+ heavier HC's	-	0.5	2.4	1.4	0.0
Carbon Dioxide (CO ₂)	0.4	0.5	2.4	0.6	0.0
Nitrogen (N ₂)	1.9	0.6	0.6	1.1	0.9
Other	1.9	2.6	-	1.3	-
Higher Calorific Value (HCV) MJ/m ³	-	43	41	42	37
Lower Calorific Value (LCV) MJ/m ³	38	39	37	37	34
Rel. density	-	0.62	0.62	0.63	0.56

Exhibit II-4. Natural Gas Composition in U.S. Cities ⁵

Component vol %	Boston	Denver	Houston	Omaha	New York	Kansas
Methane (CH ₄)	93.51	81.11	92.50	80.46	94.52	72.79
Ethane (C ₂ H ₆)	3.82	6.01	4.80	6.30	3.29	6.42
Propane (C ₃ H ₈)	0.93	2.10	2.00	2.59	0.73	2.91
Butane (C ₄ H ₁₀) + heavier HC's	0.40	0.77	0.30	0.82	0.45	0.56
Carbon Dioxide (CO ₂)	0.94	0.42	0.27	0.17	0.70	0.22
Nitrogen (N ₂)	0.39	9.19	0.13	9.32	0.31	17.10
Other	0	0.04	0	0.34	0	0
Higher Calorific Value (HCV) - Btu/ft ³	1057	1011	1031	1020	1049	945
- MJ/m ³	40	38	39	38	39	35

Exhibit II-5. Natural Gas Composition in Australian Cities ⁶

Component vol %	Darwin	Brisbane	Adelaide	Melbourne	Sydney
Methane (CH ₄)	84.75	88.49	92.50	90.60	93.30
Ethane (C ₂ H ₆)	10.66	6.05	4.90	5.60	3.30
Propane (C ₃ H ₈)	1.56	0.71	0.18	0.80	0.20
Butane (C ₄ H ₁₀) + heavier HC's	0.65	0.55	-	-	0.02
Carbon Dioxide (CO ₂)	0.11	0.57	1.72	1.70	1.80
Nitrogen (N ₂)	1.88	3.42	0.70	1.10	1.38
Other	0.39	0.21	-	0.20	-
Rel. density	0.643	0.618	0.600	0.613	0.595

U.S. gas suppliers have devised a system of classifying natural gas according to the criteria shown in Exhibit II-6.

The gas properties of concern from a vehicle fuel aspect include:

- Energy Content or Calorific Value;
- Moisture Content;
- Sulphur Content;
- Specific Gravity; and
- Stoichiometric Mixture Ratio.

⁵ "Gas Engineers Handbook", The Industrial Press Ltd. New York, 1965.

⁶ Ly, Ken (AGL Sydney Ltd.), "NGV Fast-Fill Pressure Investigation", NGV90 Natural Gas Vehicles Conference, Paper 56, Buenos Aires, Oct. 21-25, 1990.

Exhibit II-6. Natural Gas Classifications (U.S.A.)

Group	Nitrogen %	Specific Gravity	Methane %	GJ/m ³
I High Inert	6.3-16.2	0.66-0.708	71.9-83.2	32-35
II High Methane	0.1-7.39	0.59-0.614	87.6-95.7	34-36
III High Btu	1.2-7.5	0.62-0.719	85.0-90.1	36-38

Any variations in these properties will be brought about by the balance of the various individual gases occurring in the natural gas sample. It is desirable that the heavier hydrocarbon gases be at a minimum in a vehicle fuel gas. Their energy content per unit volume is greater than methane, which at first sight appears to be an advantage, but in practise they lower the octane rating of the fuel gas, leading to engine knock. They also condense at higher temperatures than methane, which can lead to blockages of gas supply and metering equipment, particularly pressure reducer valves. The International Association for Natural Gas Vehicles (IANGV) has suggested a limit of 8% on the total content of ethane, propane and butane fractions.⁷

Water and sulphur levels heavily influence corrosion of storage cylinders, valves and mixers. The IANGV has commented that one of the obstacles to the achievement of international standardization of natural gas storage cylinders is a lack of a corresponding standard gas specification.⁸ For NGVs, two control strategies are being considered. In the first approach, it is assumed that there will be some water present and therefore sulphur in the form of hydrogen sulphide is limited to eliminate stress corrosion. In the other approach, the gas is dried to a dew point 10°F below the lowest ambient temperature expected.

Exhibit II-7 gives the lower calorific values (LCV), volume air requirement for stoichiometric combustion, and energy content of the resulting mixture for individual constituent gases and a typical natural gas mixture.

It is apparent from Exhibit II-7 that while the LCV values for the primary constituents of natural gas differ widely, the energy contents of their respective stoichiometric mixtures fall within 10% of each other. The result

⁷ Stephenson, John (Editor). The International Association for Natural Gas Vehicles (IANGV), "A Position Paper on Natural Gas Vehicles 1990".

⁸ James, Bernard A. (Energy, Mines and Resources Canada), "Progress Report on the Development of an International NGV Cylinder Standard", NGV90 Natural Gas Vehicles Conference, Paper 39, Buenos Aires, Oct 21-25, 1990.

of this is that fuel gas composition may vary quite widely, but the energy content of the stoichiometric mixture changes very little. Referring to Exhibit II-7 sewage gas contains 40% CO₂, and yet the stoichiometric energy content of the gas/air mixture is only 5.7% below that of a typical natural gas/air mixture. Engine power output is dependent upon the volume of gas/air mixture which can be consumed per unit time, so for engine design purposes the gas/air mixture properties are more important than the properties of the raw gas. Hence engine power is less influenced by the composition of fuel gas used than may at first be supposed. However, a variation in performance may be expected, unless the engine fuel control system incorporates some means to compensate for variations in gas composition.

Exhibit II-7. Combustion Properties of Gases⁹

Fuel Gas	Lower Calorific Value MJ/m ³	Air Requirement m ³ air/m ³ gas	Energy Content (stoich) MJ/m ³
Methane	35.88	9.671	3.362
Ethane	64.35	17.056	3.564
Propane	93.21	24.652	3.634
Natural Gas	31.68	8.527	3.325
Sewage Gas	21.53	5.803	3.165
Hydrogen	10.78	2.410	3.161
Carbon Monoxide	12.63	2.413	3.701

Natural gas engine emissions test reports do not always comment upon the specification of the gas used as fuel. Gasoline engine emissions tests, particularly those conducted for legal certification purposes, are carried out with a standardized test fuel. It would seem logical to employ a standard gas specification to allow the same accuracy and repeatability of results. Some research has been undertaken on the issue of the influence of gas composition on emissions. Southwest Research Institute is one of the leaders in investigation of this topic.

Many natural gas utility companies maintain the energy content of their gas within specified limits according to the Wobbe index concept, to ensure no uncontrolled variations in the operation of equipment fuelled from their

⁹ Klimstra, Jacob, (N.V. Nederlandse Gasunie, Groningen, Holland), "Interchangeability of Gaseous Fuels - The Importance of the Wobbe Index", SAE Paper 861578.

supply. This is obviously a subject of concern when firing large industrial boilers or other systems requiring accurate process heat control. The Wobbe Index is an indicator of the chemical energy available in the air/gas mixture fed to a combustion process. It is based on three fundamental quantities:

- Lower Calorific Value of Fuel Gas (LCVg)
- Density of Fuel Gas (Dg)
- Density of Air (Da)

The Wobbe Index is defined as:

$$W_o = (LCVg) \times (D_a / D_g)^{0.5}$$

At pressure = 101.325 kPa, temperature = 273.15 °K

The figure quoted for natural gas relates to the Dutch Groningen Field. The Wobbe number range for domestic supplies of natural gas in Holland is 39 to 40, corresponding to a maximum variation in heating value of 2.5%.

Exhibit II-8. Wobbe Index Numbers for Natural Gas Constituents

Fuel Gas	Wobbe Index Based on Lower Calorific Value MJ/m ³
Methane	48.17
Ethane	62.86
Propane	74.75
Natural Gas	39.47
Sewage Gas	22.19
Hydrogen	40.89
Carbon Monoxide	12.84

C. NATURAL GAS PROCESSING

Wellhead natural gas is defined as being "sour" or "sweet". A gas composition is said to be sour when the hydrogen sulfide (H₂S) content is at a level that is not acceptable for general distribution and use. H₂S is highly toxic, and a major cause of corrosion due to its propensity to form sulphuric acid in the presence of moisture.

Natural gas from the North Sea is generally of good quality without processing, i.e., the heating value is high and the amount of undesirable components, such as sulphur, is low. In Canada wellhead gas frequently is high in sulphur impurities which must be removed.

At the well, extracted natural gas is passed through field separators to remove hydrocarbon condensate and water. Gas processing plants (see Exhibit II-9) are utilized for recovery of other liquefiable constituents commonly found in the natural gas, such as natural gasoline, butane, and propane.

To make sour gas sweet, the sulphur must be removed in a gas sweetening plant. The most widely used method for gas sweetening is the Amine Process, also commonly referred to as the Girdler Process. This process utilizes amine solutions (solutions derived from ammonia) for absorbing H₂S:



R = mono, di, or tri-ethanol, H = hydrogen, N = nitrogen, S = sulfur

Exhibit II-10 illustrates the process.

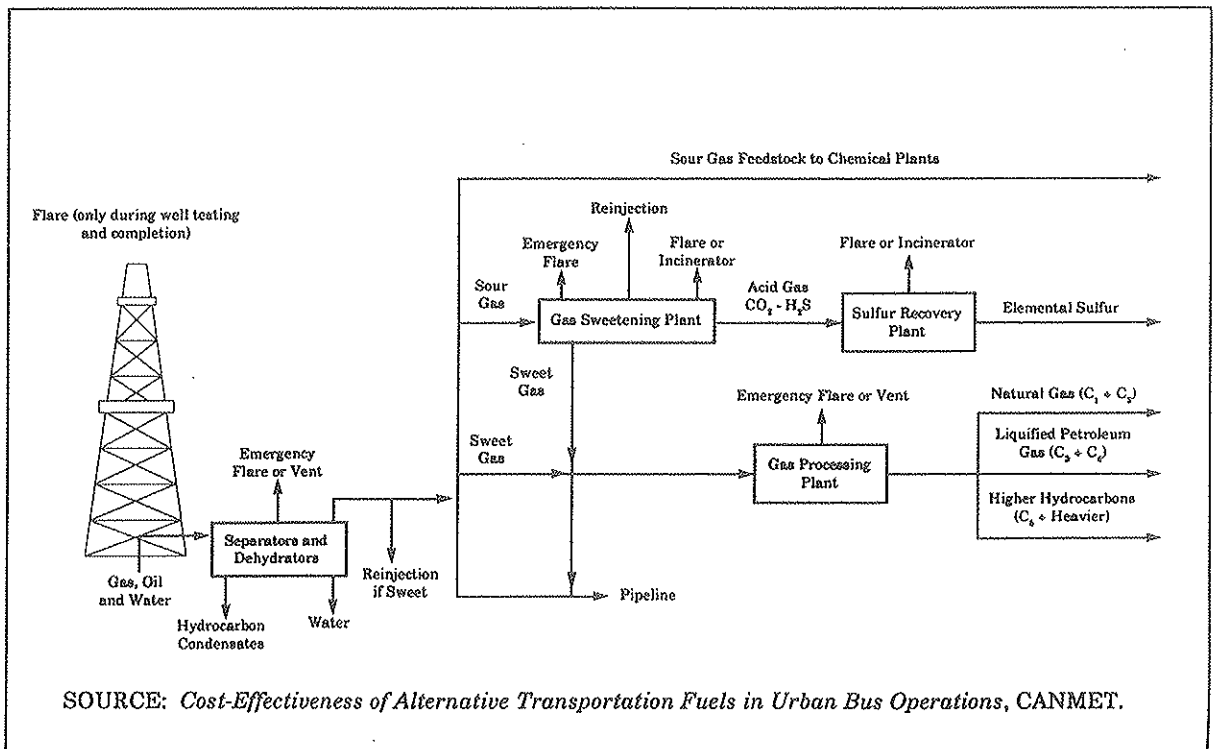

Exhibit II-9. Flow Diagram of Natural Gas Processing

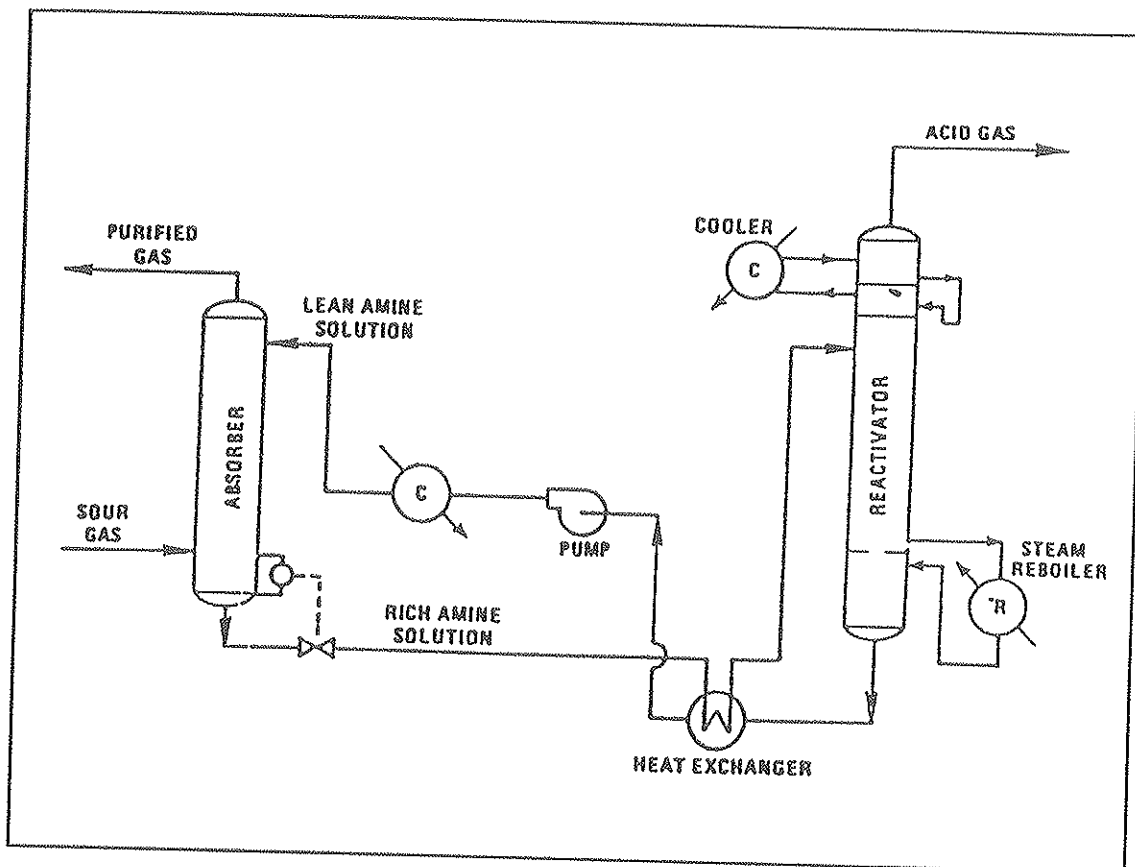

Exhibit II-10. Flow Diagram of the Amine Process for Gas Sweetening

All natural gas supplied to consumers has passed through an initial cleaning process to remove any toxic contaminants. Exact well-head purification treatment depends upon the quality of the gas concerned. Propane content is frequently separated for sale as Liquefied Petroleum Gas (LPG) fuel, since its unit value is generally much higher in that form.

Hydrogen sulphide removed from sour natural gas may be flared in waste gas flares, or used for the production of elemental sulphur. The recovery of elemental sulphur from sour natural gas is almost complete with only 0.1% of the sulphur released as airborne emissions. The sulphur is used as feedstock for products such as fertilizer and battery acid. If the water content is excessive then the gas will be dried. Water content is a major problem when pipelining and compressing gas. Exhibit II-11 shows changes in gas properties achieved by processing in Brazil. The processing removes most of the higher hydrocarbons for separate sale, and hence considerably increases the proportion of methane in the gas supply.

Exhibit II-11.

Changes in Natural Gas
Properties with Processing¹⁰

Component	Before (% content)	After (% content)
Nitrogen	1.19	1.29
CO ₂	0.48	0.5
Methane	79.38	89.35
Ethane	10.74	8.00
Propane	5.49	0.78
Butanes	2.15	0.07
Pentanes	0.53	0.01
Hexanes	0.04	0
LCV (kcal/m ³)	9.726	8.447
Density (kg/m ³)	0.8565	0.7365

D. DELIVERY SYSTEMS

Natural gas deliveries from source to consumer mostly take place through a permanent piping network. This delivery system consists of:

- transit pipes;
- main pipes;
- branch pipes;
- compressor stations;
- receiving stations (reduction of pressure); and
- distribution station and network.

In Europe, the main and branch pipelines are typically a high pressure system. The pressure of the gas is reduced in receiving stations, and the gas is then distributed to individual consumers. In some cases, the pressure of the gas is reduced by one additional step. In North America, a low pressure distribution network for household users is fairly common.

Natural gas delivery through pipelines has proven to be one of the most reliable systems to transport energy. If a supply security index is defined as the average quantity of gas that is not delivered, divided by that amount which should have been delivered if supply had not been disrupted, this index

¹⁰ de Carmo Pires, J., Lenzi Tombi, R., (Ministry of Transport, Brazil), "Natural Gas in Transportation in Brazil", NGV90 Natural Gas Vehicles Conference, Paper 67, Buenos Aires, Oct 21-25, 1990.

would yield a value of approximately 1×10^{-4} for newer pipeline systems. The figure includes all the risks of disruption in the supply from gas source, for example the North Sea, to the individual consumer.

In order to improve preparedness in the event of a disruption many supply utilities or municipalities have natural gas storage systems.

E. LIQUID NATURAL GAS AND GAS PRICING

In order to ship natural gas in tankers the fuel must be liquefied. This is a costly procedure, and requires large facilities. With current refrigeration and compression technology, it has been estimated that a production complex must have a minimum annual capacity of 4 Mt/year in order to support an export market. The industry is however relatively new, and some improvements in the efficiency and cost of the liquefying gas may be expected. As it is still the least expensive method of shipping natural gas over long distances, the cost and availability of LNG technology will play an important role in the future development of international prices for natural gas.

The number of countries that have blocks of exportable reserves of sufficient size to justify LNG production facilities is limited. The USSR, Iran, Abu Dhabi and Qatar alone, hold more than 75% of the world's exportable surplus gas. Other countries with sufficient reserves to consider developing LNG facilities include Nigeria, Norway, Australia, Algeria, Malaysia, Venezuela and Trinidad.

Ultimately the most important determinant of the viability of developing LNG export facilities is the price that the product will bring on the world market. Natural gas pricing is quite different from crude oil, although in many markets there is a strong linkage.

Crude oil by its very nature, multiple sources and easy transportation, trades as an international commodity. It has identifiable world prices and, as recent global events have shown, is capable of substantial price swings of a purely speculative nature. Natural gas, where there are extensive pipeline systems and multiple producers, has also developed a competitive, commodity style price structure. This is the case in most of North America and some parts of Europe. In most other areas of the world natural gas pricing is tied into long term supply contracts and there is in effect no world price.

If a country wishes to import Liquefied Natural Gas it must find an exporter with available capacity, special dedicated ships, and it must provide a receiving terminal. All are expensive propositions that are rarely built prior to contracts being in place. It is not possible to buy significant quantities of

LNG on a spot market in the same way that crude oil is virtually always available at a price. Without the existence of a price setting, competitive demand driven market most LNG export contracts have prices established from other benchmarks. The most frequent benchmark is a relationship with crude oil. These prices are referred to as "administered" rather than "market".

The historical relationship of natural gas prices to crude oil may be challenged in the future. This may occur if natural gas becomes a more widespread alternative to coal for environmental reasons, and the clean burning characteristics of the fuel create a large demand as a transportation fuel. The link to oil prices may weaken, but for the foreseeable future there will be a strong connection between crude oil and natural gas pricing.

Jensen identifies three separate mechanisms in place for pricing natural gas at the present time. These are:

- **Market netback**, which exists in North America where there is a competitive, demand driven, market for gas.
- **Administered price**, which exists in much of Europe, resulting from negotiations between government buyers and sellers. Gas prices are generally oil-related.
- **Project economics**, which can exist where neither of the two previous methods have been established. In this situation, the price of the fuel will be determined solely by the cost of production, royalties, and liquefaction, with a commercial rate of return on the capital.

Jensen prepared twenty year price forecasts for natural gas prices starting in 1990. The first forecast was based on the price for crude oil remaining constant from 1990 to 2010, while the second was based on crude oil rising to \$35 by 2010, and then holding steady. Based on these two scenarios for crude oil prices, Jensen projected the price of natural gas at a number of locations around the world. The locations of most interest to IEA countries participating in this study are presented in Exhibit II-12.

According to the forecasts, prices would be lower in Europe than in North America. Prices of natural gas are expected to increase in North America, even with constant oil prices. Given that prices in Europe are more administered than market driven, prices should remain more stable as estimated by Jensen. It is expected that gas prices will remain related to oil. Thus, gas prices appear to favour NGVs more in Europe than in North America.

Exhibit II-12. Projected Natural Gas Prices (Jensen)

	CONSTANT OIL PRICE CASE			RISING OIL PRICE CASE		
	1990 \$/GJ	2000 \$/GJ	2010 \$/GJ	1990 \$/GJ	2000 \$/GJ	2010 \$/GJ
Japan	3.30	3.30	3.30	3.30	5.70	5.70
North America - U.S. Gulf Coast	2.12	2.77	3.42	2.00	4.19	4.74
- Alberta	1.66	2.31	2.94	1.57	3.70	4.23
Atlantic Basin - Norway: Tromsflaket	1.57	1.57	1.57	1.57	1.61	1.84
Frigg	1.05	1.05	1.05	1.05	1.93	1.66
East Frigg	1.82	1.82	1.82	1.82	1.82	2.06
U.S.S.R. - W. Siberia	2.00	2.00	2.00	1.94	3.55	3.55

Note: GJ - Gigajoule

Gas prices in North America have recently been in the range from US\$1.00 to US\$1.50 per Gigajoule. For example, a recent major sale of gas from Canada to California was set at US\$1.50 per 1000 cubic feet (\$1.47/GJ). This pricing, if it continues, will impact favourably on the feasibility of using natural gas in motor vehicles in North America.

F. BIOGAS SUPPLIES

Biogas primarily consists of methane and carbon dioxide. It is produced by anaerobic microbiological processing of organic materials. Potential feedstocks include:

- Sewage effluents;
- Animal manure;
- Household refuse; and
- Agricultural crops.

Almost any kind of organic matter may be used to produce biogas under the right conditions. In practice the preferred sources are sewage and animal manures. Many large sewage treatment plants use biogas to power pumping engines and other machinery, but this often takes only a small proportion of the potential energy available. In Sweden the Henriksdals sewage treatment plant in Stockholm is being used as the biogas generation site for a transit

bus project. The plant already produces about 8 million cubic metres of biogas annually. 1 million cubic metres is used in a heating boiler plant, 4 million cubic metres is used to power the plant machinery, and 3 million cubic metres is required to run the biogas generation process. The project estimates that by making internal economies of gas consumption enough surplus to propel 100 transit buses 150 km daily can be made available.

Exhibit II-13 shows estimates of the total energy potentially available from organic waste in Sweden. Most of the waste is currently disposed of by burning or landfill deposition. The population of Sweden is about 8.5 million people. An estimate of the biogas potential from organic waste for other countries can be made by considering the average biogas potential in Sweden, which is 7 gigajoules per capita per year, equivalent in energy to about 200 litres of gasoline. This is subject to the condition that the country is similar to Sweden in terms of agriculture, industry profile etc.

Another way to produce biogas is to grow crops for that specific purpose. It is then possible to achieve about 70 gigajoules gas energy content per hectare, depending on the crop used.

Exhibit II-13. Biogas Energy Potential from Organic Waste in Sweden (TWh/year)

Source	Solid Waste	Liquid Waste	Sewage Water	Total
Industry	1.0	0.3	1.8	3.1
Municipal	1.7	0.5	-	2.2
Farming	9.1	1.4	-	10.5
Total	11.8	2.2	1.8	15.8

Note: 1 Tera (10^{12}) watt hour = 3.6 Peta (10^{15}) Joules

In theory the biogas available from farm and forest crops is virtually unlimited, and the production process is easy to implement. However, the practicalities and economics of production place many constraints on the feasibility of widespread generation from agricultural produce.

Process Technology

The organic breakdown of biomass to produce methane is commonly referred to as "digestion", since the process has much in common with the functions occurring in human and animal digestive systems. It may also be likened to an acceleration of the biological processes which result in the creation of natural gas. The equipment used is accordingly called a "digester". A digester is basically a sealed vessel into which the biomass feedstock is placed, in the form of liquid slurry, and held at a suitable temperature for maximum microbiological activity. The methane generated bubbles to the surface of the slurry and is piped away through the top of the vessel for purifying and use.

The simplest type of digester is the single step "batch process" design. In this type, the slurry is left until digestion is complete and gas generation has ceased. The waste sludge remaining is then emptied out, the digester is cleaned and refilled with slurry, and the process begins again. Nowadays the most common process used is continuous feed, in which slurry is added into the digester on a continuous basis, with a corresponding amount of waste sludge being continuously discharged. The efficiency of gas generation depends on the relationship between the residence time of the biomass in the digester, and the rate of microbiological activity. Obviously it is inefficient to discharge waste matter which is still actively generating methane at a high rate. Exhibit II-14 is a diagram of a continuous feed digester.

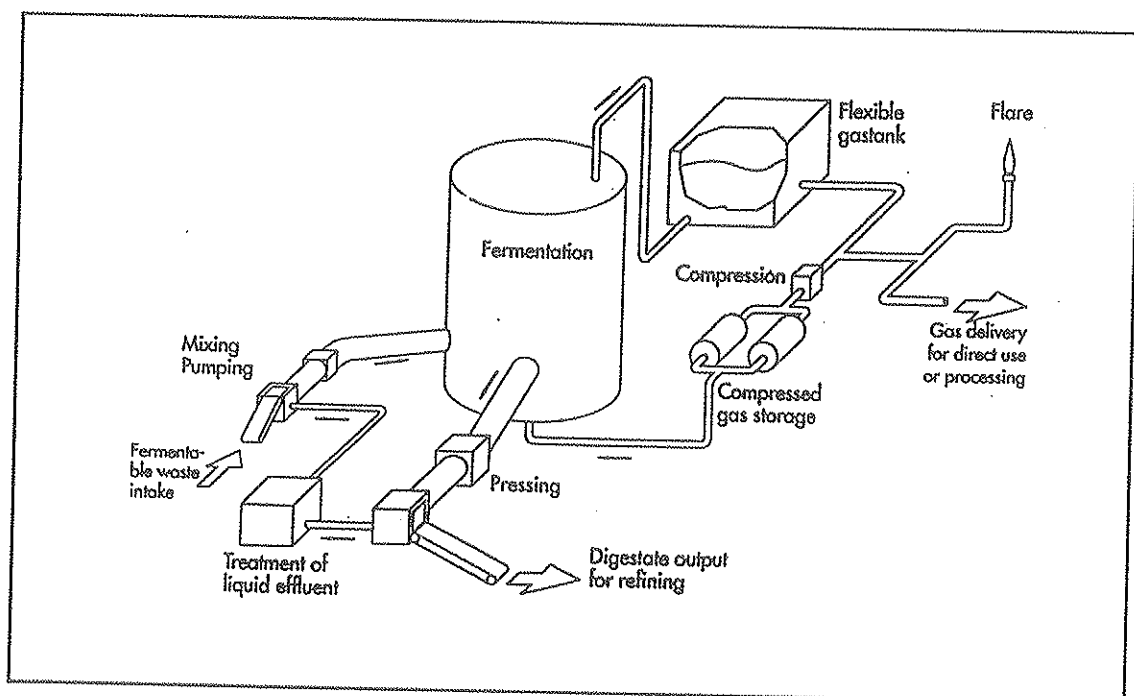

Exhibit II-14. Continuous Feed Biogas Digester

The main advantage of a continuous feed digester is a steady supply of gas at a predictable rate. It is necessary to carefully balance the charging rate, operating temperature, pH levels and several other chemical process parameters in order to ensure maximum gas generation and prevent premature discharge of good feedstock. With the batch process the gas generation rate tapers off as the final stages of digestion are reached, and obviously no gas is generated while emptying and recharging takes place. In a large installation a number of batch digesters may be used so that some are still generating while others are being cleaned and reloaded. In this way a relatively constant overall supply of gas may be achieved.

The design of a process for digestion of organic matter depends on the type of feedstock. Undigested crop matter floats while sewage and manure solids tend to sink. The absence of mixing in a crop digestion process will lead to a floating bed of fresh crop in the top section of the digester. As this mass is attacked by bacteria from below, it will eventually sink to the bottom of the digester carrying the bacteria with it. Therefore a mixing system for crop material is essential to perform the following functions:

- Return bacteria from the bottom of the digester to the undigested crop at the top;
- Prevent the crop from forming an impenetrable mass that does not allow the biogas to escape;
- Keep the crop material agitated; and
- Ensure heat transfer in the process.

Mixing of manures and sewage is often accomplished with jets of bubbles produced by recirculating gas from the top of the digester. The digestion process is very temperature sensitive. Two distinct temperature ranges may be used, 30 to 40°C and 50 to 60°C. These ranges are dictated by the activity of distinct strains of bacteria involved. In practice the lower temperature range is preferred, primarily because it requires less energy to maintain. The thermal energy required for digestion can be up to 15% of gas energy produced. Gas generation drops off rapidly if the ideal temperature range is not maintained, at 16°C the volumetric generation rate is about 5% of that at 36°C.

Over the last few years research and development has been conducted on a continuous two-step process. In this process, the digestion of the organic material takes place in two steps in separate digesters. During the first step organic material is broken down into less complex hydrocarbon compounds in the hydrolysis digester. The slurry then passes into a second digester

where methane is generated. The advantage of the two-step process is that it is possible to obtain a higher quality biogas, i.e., about 70% to 75% methane content, compared to 50% to 55% with a one-step process. However, the one-step continuous principle is a well-known and proven technology, in contrast to the two-step process, which is not yet developed for full scale use.

Purification Technology

Biogas recovered from a digester contains methane, carbon dioxide, sulphides, and water vapour. The gas must be purified before it can be used as a fuel for vehicles. During the purification process carbon dioxide is removed to increase the energy density of the fuel gas.

Water scrubbing and membrane separation are the most common methods for removing carbon dioxide and hydrogen sulphide. Water scrubbing uses a scrubber tower in which the gas, slightly compressed, passes upwards as water passes in the opposite direction. Sodium hydroxide (NaOH) is added to the wash water, and the resultant reaction with CO₂ produces sodium carbonate. The method is simple, well-proven and applicable to large or small-scale operations. Depending on the design features, it is possible to remove nearly all carbon dioxide from the biogas.

Membrane separation is based on the difference in partial pressure of methane and carbon dioxide across a membrane consisting of hollow polymeric fibres. As a pressurized gas stream passes over the membrane, faster permeating gases are separated from slower permeating gases. Membrane separation has proven to be the most economical method of purifying biogas in larger scale operations. For smaller plants, i.e. under 50m³/hour, water scrubbing is still economically favourable.

An alternative method of removing sulphur contamination is to pass the gas through a filter consisting of wood chips and iron filings. The Swedish biogas project at Hendriksdals in Stockholm generates raw biogas containing 65 to 75% methane and 23 to 35% carbon dioxide, plus miscellaneous contaminants including nitrogen, hydrogen, and carbon monoxide. After purification the gas contains 93 to 98% methane and 1 to 4% carbon dioxide. H₂S content is reduced from between 0.001 and 0.1% to as low as 0.0001%.

Costs

The cost to produce biogas is a function of the feedstock employed, the digester capacity, and the purification costs. In the case of a digester capable of producing 1-2MW, costs, as depicted in Exhibit II-15, will total

approximately \$0.10/kWh (\$27/GJ). This includes costs for cultivating and harvesting the crop, as well as capital and depreciation costs on the investments. The costs for purification include gas preparation to a quality suitable for use in a motor vehicle, and compression.

Exhibit II-15. Costs for Biogas Production

Biogas Production	Costs \$/kWh	\$/GJ
Biogas production	0.07	19
Gas purification and compression	<u>0.03</u>	<u>8</u>
Total Costs	0.10	27

The cost of biogas production is greatly influenced by the size of plant. The difference between a 4MW and a 0.5MW-plant ranges from US\$0.06/kWh to US\$0.1/kWh (\$16-27/GJ). In comparison with natural gas it appears that biogas is much more expensive as an energy source.

The production cost of biogas typically breaks down as follows:

- capital : 24%
- operation and maintenance : 15%
- distribution : 20%
- crop (minus value of products) : 40%

If biogas is available as a by-product, such as at a landfill or at a municipal sewage-treatment plant, then production costs would be limited to purification costs. Similarly, farmers are in a position to produce low cost biogas. Crop and distribution costs could be drastically reduced by using animal manure products.

G. SUMMARY

Supply And Demand Of Methane

The exportable surplus of natural gas is 43% of the world's proven resources of 4,000 Trillion cubic feet (115 Trillion cubic metres). The world continues to add to the proven reserves of natural gas faster than it is being consumed. (6 versus 2 trillion cubic metres per year). Thus there is definitely a large supply available for NGVs.

However much of the growth in exportable reserves is occurring in relatively isolated locations such as Siberia and the Middle East. If NGVs were to capture major segments of the transportation market (eg., 5-10%) in Europe and North America, additional international shipments could be required in the form of LNG or intercontinental pipelines.

Russia, Iran, Abu Dhabi, and Qatar hold more than 75% of the world's exportable surplus. Nigeria, Norway, Australia, Algeria, Venezuela and Trinidad also have enough reserves to support LNG facilities.

Biogas from waste is another major source of methane that will be of increasing interest in the future as a means of reducing urban environmental damage.

Gas Properties

The composition of natural gas and methane varies considerably geographically. Substantial processing is required but is part of the existing natural gas supply infrastructure. The pipeline composition of natural gas is important for vehicle use for the following reasons:

- Heavier hydrocarbons (ethane, propane, and butane) lower octane rating, leading to engine knock.
- Heavier hydrocarbons condense more easily, which can lead to blockages of gas supply and metering equipment. The IANGV has recommended a limit of 8% for these hydrocarbons.
- Water and hydrogen sulphide influence corrosion of NGV steel storage cylinders, valves and mixers. The valves can also be frozen if precautions are not taken.

Thus, there is a need for standard gas specifications that engine manufacturers can design to. Engine fuel control systems will need to compensate for variations in gas composition in order to avoid variation in engine performance. Gas quality may also affect exhaust gas emissions but very little research has been done. The IEA should support efforts in this area.

Gas Prices

In the foreseeable future, there will continue to be a strong link between crude oil and natural gas pricing. According to forecasts, prices will be more favourable in Europe than in North America. Prices of natural gas are expected to increase in North America, even with constant oil prices. Given that prices in Europe are more administered than market driven, prices

should remain more stable. Thus, gas prices appear to favour NGVs more in Europe than in North America, although recent prices in North America have been lower than anticipated several years ago. Biogas, although technically feasible, appears to be more expensive than natural gas as an energy source.

III VEHICLE FUELLING TECHNOLOGY

A. COMPRESSED NATURAL GAS

There are three basic types of compressed natural gas (CNG) refuelling facilities:

- Slow Fill (Large and Small Capacity);
- Fast Fill;
- "Mother-Daughter" or "Satellite" Distribution System.

Slow Fill Fuelling

A slow fill system operates by progressively pressurizing the vehicle cylinders over an appreciable period of time. The gas supply is not pressurized ahead of demand. Slow fill systems are usually arranged to charge unattended vehicles during periods out of service. The operator connects the gas feed pipe, turns on the supply and leaves the compressor running to fill the vehicle cylinders. The process is comparable to recharging the batteries of an electric vehicle. It is often referred to as "trickle charging".

Slow fill refuelling is suited to a situation where vehicles are periodically returned to the same location for an extended duration. An urban bus fleet is an ideal example. It cannot be used at retail service stations, where vehicles must be refuelled on a random basis, in times comparable to refuelling with gasoline or diesel.

A typical slow fill system refuels several vehicles simultaneously, as shown in Exhibit III-1. The compressor feeds into a gas distribution manifold, and an outlet is provided for each vehicle. The actual speed of refuelling will depend on the number of vehicles connected to the system, the amount of natural gas storage capacity on the vehicles, and the capacity of the gas compressor. Slow fill is not suited to vehicles in operation 24 hours per day, or required for emergency call out, unless the vehicles have bi-fuel capability.

Slow fill capabilities can also be provided as an adjunct to a fast fill compressor station. A combined slow and fast fill system provides an opportunity to increase the overall refuelling capacity by enabling parked vehicles to fuel unattended overnight. This may alleviate daytime congestion at the fast fuelling dispensers, and reduce the amount of time lost through refuelling stops.

Slow fill technology has been in existence the longest of the three technologies now available for refuelling NGVs. There are a variety of companies producing the equipment, and it is readily available in Europe, North America, Latin America, and Australasia. The technology is well developed. Continuing design refinements and mass production of components could result in lower costs in the future. The current capital cost in the U.S.A. for a stand alone slow fill fuelling system, capable of fuelling a fleet of 35 light duty vehicles, would be about US\$45,000, or US\$1,300 per vehicle. In Canada, the cost would probably be approximately Cdn\$75,000.

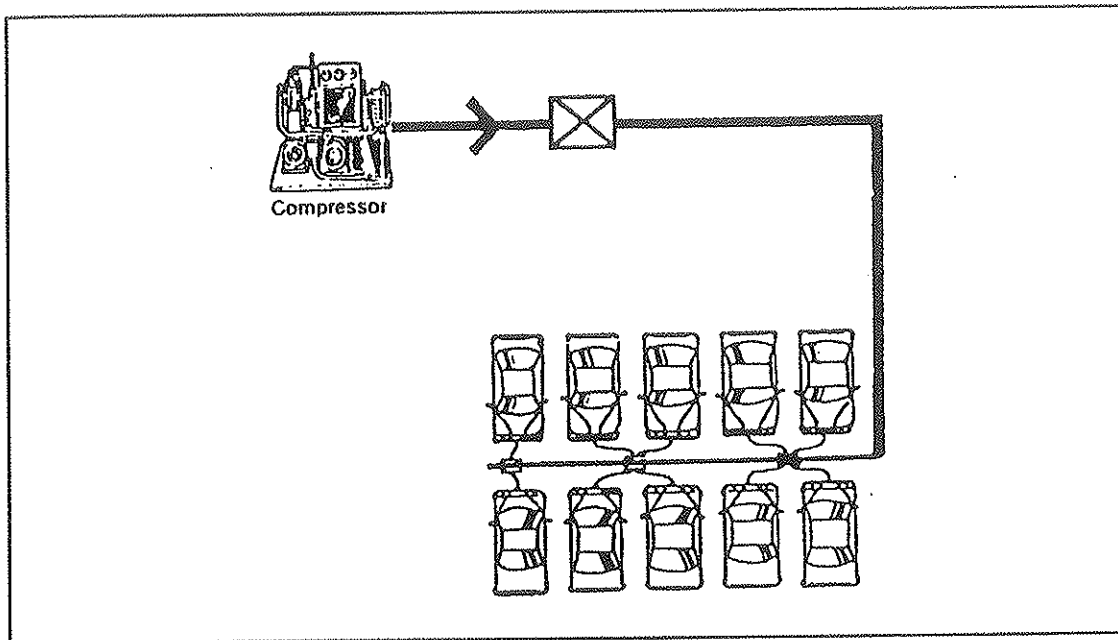

Exhibit III-1. Slow Fill Fuelling System

Slow fill refuelling can be extended into the private owner and small fleet market with individual vehicle refuelling appliances. These contain a small electrically powered compressor that enables one or two vehicles to be filled in 6 to 8 hours, using gas supplied from the underground residential distribution system. A vehicle refuelling appliance (Exhibit III-2) can easily be added on to a normal domestic gas supply for use at home. The gas is metered through the existing gas meter, and the owner is charged for the amount consumed as part of the regular utility gas bill. These small vehicle refuelling appliances are presently being manufactured and sold in Europe, New Zealand and North America. The technology is still developing, and some problems were initially encountered in cold climate applications when the ambient temperature was below zero for extended periods. Manufacturers are reporting that interest is growing, and in North America production is not able to meet current demand. In Canada over 600 of these appliances were in use in mid 1991.

The slow fill unit cost (as measured in infrastructure cost per vehicle refuelled) is greater for the vehicle refuelling appliance than for centralized slow fill refuelling. The cost for vehicle refuelling appliances is presently about US\$2,500 per vehicle, compared to US\$1,300 per vehicle for centralized slow fill. The manufacturers of the vehicle appliances believe that technological development and increased production rates will reduce this cost differential.

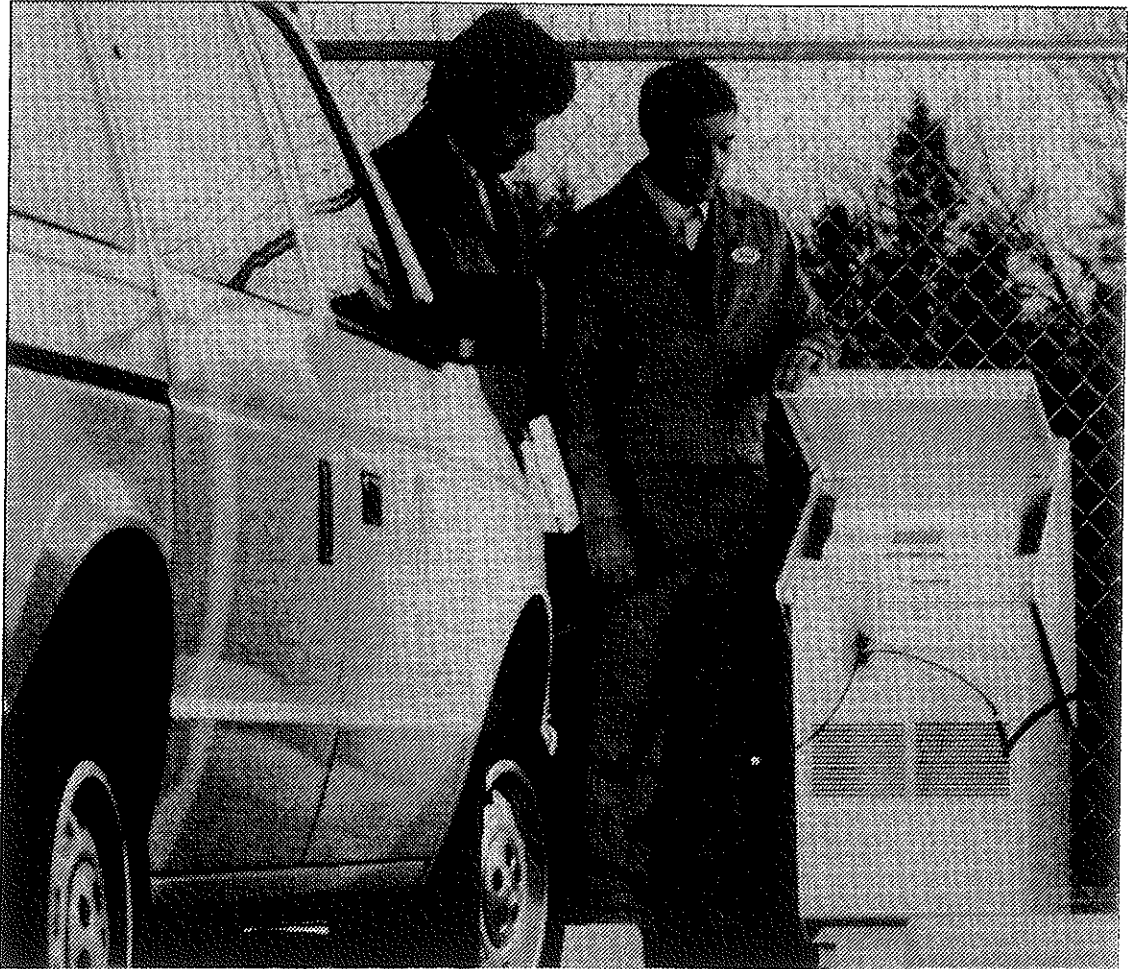

Exhibit III-2. Vehicle Refuelling Appliance

Fast Fill Fuelling

A fast fill compressor station is capable of fuelling a natural gas vehicle in a comparable time to that required to fuel a similar vehicle with diesel or gasoline. This implies having large volumes of gas at high pressure immediately available for delivery into the vehicle cylinders upon demand.

Fast fill refuelling installations are comprised of large capacity compressors and storage in the form of cylinder "cascades". (Exhibit III-3). The compressor may be driven by an electric motor or stationary natural gas engine. The cascade acts as a storage buffer, and permits the system to deliver gas at a greater flow rate than the maximum compressor capacity by supplementing the compressor output with pre-pressurized gas.

The size and power of the compressor will determine how quickly the cascades are recharged, while the cascade storage capacity determines how many vehicles can be refuelled before having to recharge. The anticipated demand on the fuelling station, which includes the average volume dispensed per vehicle and the number of vehicles fuelled per unit time, must be accurately identified. Correct sizing of the compressor and cascades for the application are essential if refuelling time and system cost are to be optimized.

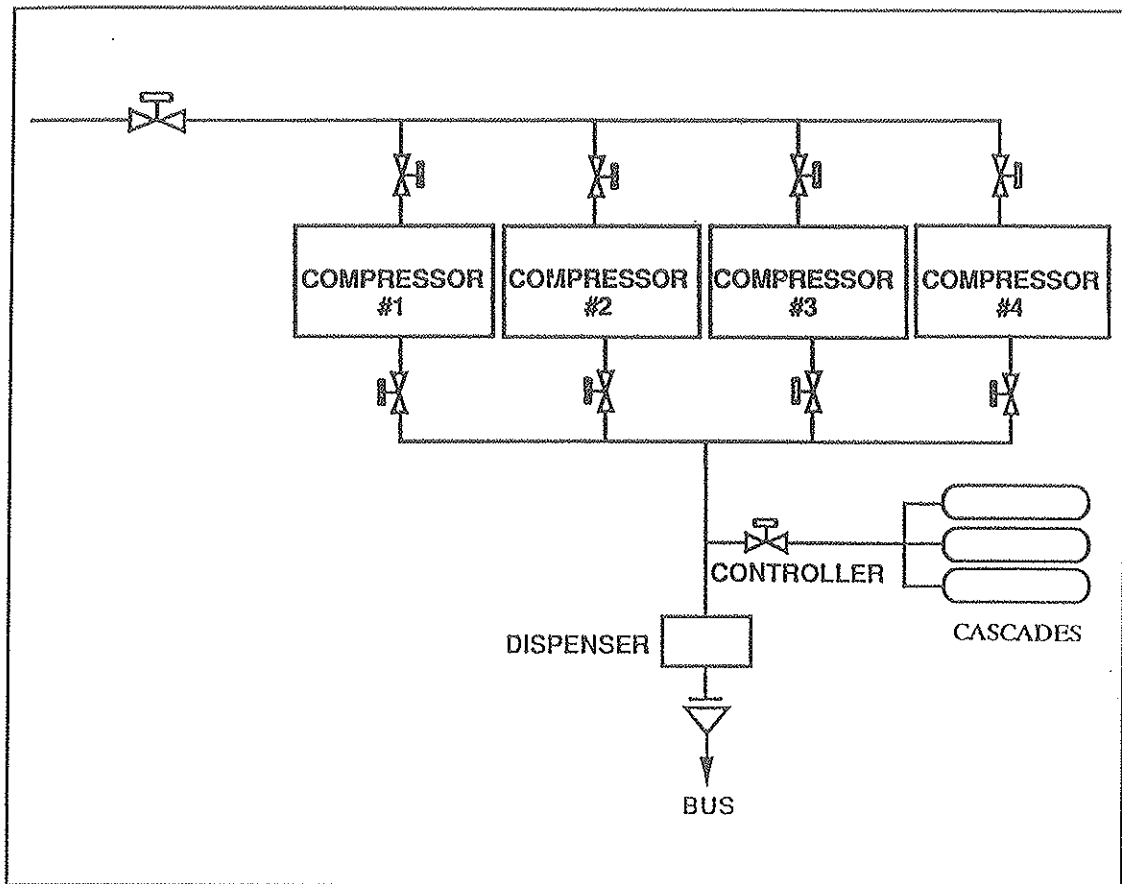

Exhibit III-3. Fast Fill Fuelling System

Fast filling relies on maintaining an adequate pressure differential between the refuelling station cascades and the vehicle cylinders. The maximum working pressure for the cascades is normally about 25 MPa. The instantaneous rate of fuel flow depends upon several parameters, including the temperatures of the cascade and vehicle cylinders and the flow restrictions in the refuelling station and vehicle piping and valve systems. The general tendency is for the fuel flow rate to start at maximum, and to gradually taper off as cascade pressure falls and the vehicle cylinder pressure rises. Because of the interplay of instantaneous pressure and temperature conditions, and variations in the flow resistance of individual vehicle gas piping systems, the relationship between the amount of fuel pumped into a

vehicle and elapsed time is not as simple as for a liquid fuel. In practice, it is nearly impossible to accurately predict the necessary time to refuel, and there is a considerable risk of underfilling a vehicle, particularly if the fuelling system is set to eliminate any danger of over-pressurizing the vehicle cylinders.

Modern fast fill refuelling stations incorporate electronic feedback control loops which monitor temperatures, pressures, mass flow rates etc., in order to maintain consistency of cylinder filling within close limits.

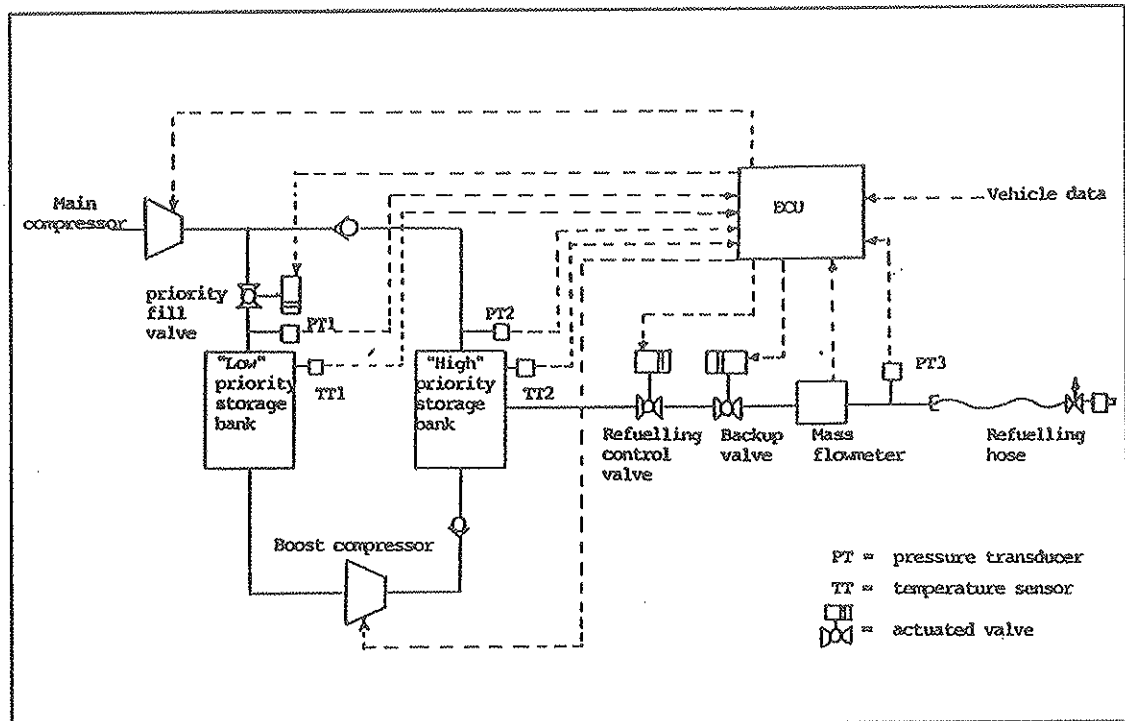

Exhibit III-4. Electronically Controlled CNG Fuelling Station

Exhibit III-4 depicts a system developed by AGL, Sydney, Australia, for use within a large volume, high demand environment, such as an urban bus operation.¹¹

The microprocessor control unit senses when the correct fill pressure corresponding to the cylinder temperature has been reached, and stops the refuelling process. The "high" and "low" priority banks of storage cylinders are part of the AGL system, and not mandatory for operation of a "smart"

¹¹ Ly, K. H. et al, (AGL Ltd., Sydney, Australia); "Electronically Controlled NGV Stations For Correct Large Volume Fast Fuelling". Paper presented at NGV '90 2nd International - Conference and Exhibition, Buenos Aires, Argentina, October 1990. Paper #57.

fuelling station. In this particular design, the high and low priority cylinders overcome the need for a very large high pressure storage volume. Instead, the low priority bank and boost compressor maintain the high priority bank during peak demand periods.

Fast fill systems are used for retail service station sales to general vehicle users. A typical natural gas station is virtually indistinguishable from a gasoline station, and the process of refuelling a vehicle is very similar. One current drawback is that many countries have safety regulations requiring that refuelling be carried out only by specially trained operatives. This prevents self-service refuelling. It is expected that as experience of natural gas fuelling grows, and a satisfactory safety history is established, any restrictions will be brought into line with those governing gasoline dispensing. There is also a need for standardization of service station and vehicle delivery nozzles. A number of competing designs are available, and it is obviously necessary to provide the widest possible interchangeability between vehicles and refuelling stations. In a further move toward user convenience, some of the latest conversion kits locate the filler nozzle in a similar position to a gasoline filler, so avoiding the need to open the engine hood when refuelling.

The cost of fast fill systems can vary significantly depending on the configuration and vehicle refuelling capacity. A typical system in North America, designed to economically serve about 100 vehicles per day, costs approximately US\$250,000. The peak service rate would be about 20 light vehicles per hour. Systems designed to accommodate a large fleet of trucks or buses would cost considerably more, since they would be required to operate at high capacity for long periods. A system to refuel 10 transit buses per hour for the Toronto Transit Commission in Canada is estimated to cost approximately US\$2.5 million. The Government of Ontario, Canada, is using an estimate of Cdn\$23,000 per bus as the cost of providing fuel compressor stations in feasibility studies of prospective natural gas transit fleets. Exhibit III-5 shows the relationship between time to refuel a vehicle and the cost of a compressor station suitable for a typical transit bus fleet. This chart was prepared by Ontario Bus Industries.

The cost estimates given would be subject to variation depending on specific local conditions, and the availability and pressure of a local natural gas pipeline distribution system.

City passenger transit systems, and many other fleets, cannot risk having operations shut down by lack of fuel. In situations where monofuel NGVs are in operation there may therefore be a requirement to build redundant emergency refuelling capacity. This could increase the cost of providing the complete refuelling infrastructure. Even in countries and cities where natural gas fuelling stations are relatively common it would be difficult for any single facility to replace the capacity lost by a total system failure at another site.

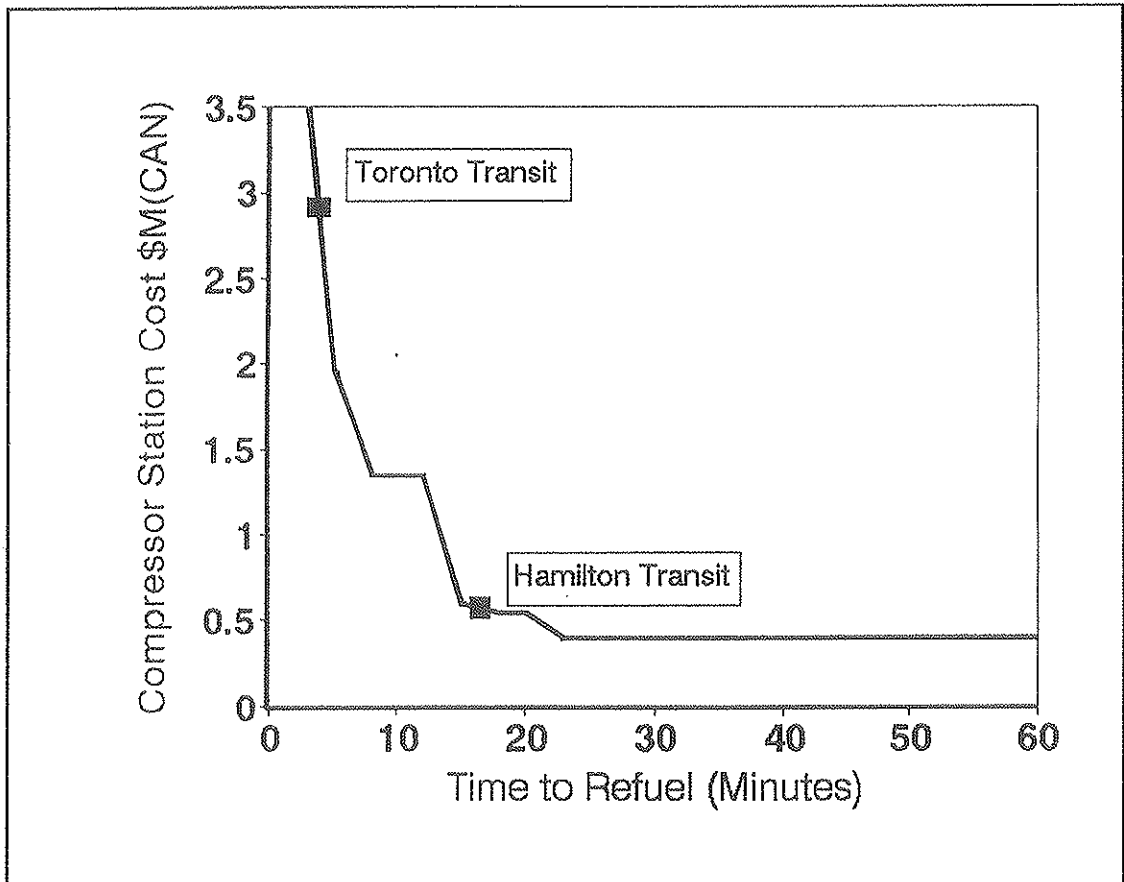

Exhibit III-5. Vehicle Fuelling Time/Cost Relationship

"Mother-Daughter" System

"Mother-Daughter" systems involve a hybrid approach utilizing a high capacity central compressor station, and dispersed slow fill facilities at remote locations. In a typical system, tank trailers are charged with natural gas at the central facility, and then travel to the required refuelling location. Each trailer may carry a small compressor unit enabling it to function as a self contained slow fill fuelling station. Alternatively, trailers are connected singly or in cascade to a compressor and manifold distribution system permanently installed at the fuelling station. The fuel in the tank trailer can be fed directly into vehicles, or pumped into fixed storage cylinders at the site.

B. LIQUEFIED NATURAL GAS

Storage

Liquefied natural gas (LNG) is normally stored at a temperature of -165°C , and pressure of 0.4 MPa. The resultant energy storage density is approximately 70% of that of diesel fuel. Storage vessels are normally

cylindrical or spherical in construction, and have double walls separated by a layer of insulation or a vacuum. Industrial tank capacities range up to 100,000 m³. It is not economical or practical to refrigerate LNG in storage. Maintenance of the cryogenic temperature depends upon the efficiency of the tank insulation alone. "Boil-off" of evaporating gas is therefore a feature of storage, but in practise the loss is less than 1% per day. Boil-off gas can be collected for re-liquefaction, so that there is no release of methane to atmosphere. Industrial storage tank temperature is kept stable over the long term by the regular passage of gas in from the liquefaction plant and out to the user plant. In large tanks, stratification of the individual liquefied gases can occur (i.e. methane, propane, butane etc.) owing to their different densities and boiling points. It is sometimes advantageous to circulate the tank contents through a cryogenic pump in order to maintain temperature stability, and assist in balanced evaporation of the gas mixture for feeding to the process plant.

Transport

Liquefaction is the most efficient way of transporting large quantities of natural gas where a pipeline service is not available. LNG may be carried in tanker trucks, rail cars, and ships. In 1989 there were over 700 sea-going LNG tanker ships operating, with capacities up to 136,000 cubic metres. Some ships use the boil-off gas to fuel the marine engines. Loading and unloading is carried out at specially built terminals, capable of discharging a whole vessel in around 12 hours.

Overland LNG transport is used in situations where the traffic volume makes the economics of a pipeline marginal; or special circumstances, such as environmental considerations, prevent pipeline construction. One example is the traffic from Canada into the north-eastern U.S. during the high energy demand winter period. Tanker trucks with capacities up to 50,000 L are used. The traffic has steadily grown in volume over the past 15 years, during which time an excellent safety record has been maintained. In Australia LNG is hauled from a liquefaction plant at Alice Springs, over a distance of 450 km to a power station at Yulara. Twin tanker trailers with a total capacity of 60,000 L are used. The company operating the trucks has recently taken the logical step of investigating the possibility of using LNG as the vehicle fuel.

Transport of LNG by road, rail or sea is a well developed technology. There are no engineering barriers to expanding the transportation network to wherever it may be required, if it can be justified economically.

Refuelling

Use of LNG as a vehicle fuel to date has been on a very restricted scale, in experimental situations. There is no standardized method of refuelling LNG powered vehicles, or quantity manufacture of appropriate equipment.

An LNG refuelling station requires a storage tank, a cryogenic delivery pump, a flow meter, and a delivery hose and nozzle to connect to the vehicle. The entire system has to be kept at a temperature of -165°C , and a pressure of approximately 1 MPa. It is difficult to predict typical refuelling times or construction costs, because so few practical installations have been constructed. Refuelling time could be the same as for diesel or gasoline if a sufficiently large pump and delivery nozzle are provided. System cost depends upon individual design, including whether local or central liquefaction is employed, the pressure of the main natural gas supply pipeline, and the quality of the gas supplied. The basic techniques of LNG fluid transfer are very well known. There is a need to scale down existing equipment to sizes appropriate for vehicle use.

There are two primary options for construction of an LNG refuelling station:

- Liquefaction and storage on-site.
- Central liquefaction, delivery to on-site storage.

Both of these options are technically feasible. One advantage of on-site liquefaction is that the existing local gas pipeline network may be used for gas distribution. A disadvantage is the need for liquefaction equipment at every fuelling station, and everything that this implies in terms of cost, complication, safety and maintenance requirements.

Centralized liquefaction allows for economy of scale in the actual liquefaction process. The higher pressures available in main trunk pipelines may be exploited to operate some of the necessary plant. A disadvantage is the need to transport the LNG by road to the vehicle fuelling stations, and the larger volume of LNG required to be stored at each site. Some arrangement would have to be made to control gas boil-off, ideally by diverting it to some useful purpose. This problem would also exist in the case of on-site liquefaction, but it is assumed that in this case a much smaller volume of gas would be held in storage, with correspondingly less boil-off. With an on-site liquefier available, boil-off could simply be diverted back into the liquefier inlet stream.

Cryogas Ltd., of Vancouver developed an on-site liquefaction system capable of liquefying between 3,000 m³ and 30,000 m³ of natural gas per day.¹² Two basic liquefaction processes were proposed. Where a high pressure (3 MPa to 8 MPa) pipeline supply is available, part of the liquefaction process may be accomplished by a turbo-expander acting across the pressure drop between the trunk pipeline and the local distribution network. Where high pressure gas is not available, a conventional compression/expansion cycle liquefier may be used. Carbon dioxide and water vapour must always be removed before liquefaction.

Some experimental low-volume LNG vehicle fuelling systems have used the pressure gradient between the bulk storage tank and the empty vehicle tank for fuel transfer. Gravity flow is also possible. However neither of these methods can provide flow rates high enough for regular fleet requirements. The Cryogas system used a submerged pump to provide the necessary flow rate, similar in principle to large industrial installations. For gas metering the system can use an electronic mass flow rate meter, providing accuracy conforming to retail weights and measures standards. Because the gas is in a liquid state the refuelling time may be predicted with accuracy and the risk of underfilling associated with compressed gas does not arise.

A complete Cryogas on-site liquefaction and dispensing system was employed for trials of an LNG mining truck in western Canada in 1988. The system, excepting the associated storage tank, was packaged into a portable container. Delivery to the vehicle was through a vacuum jacketed hose, with a nozzle connecting to a positive locking nozzle on the vehicle tank.

C. SUMMARY

Both compressed and liquefied natural gas require more complex vehicle fuelling arrangements than liquid petroleum fuels. The technology for CNG is generally technically mature. There are a number of possible methods: fast-fill, slow fill, "mother-daughter" mobile stations, and domestic home refuelling appliances. The specific approach, installation, capacity and costs are dependent on the vehicle or fleet application. Public fast-fill fuelling stations capable of refuelling about 20 cars per hour currently cost about US\$250,000. Systems for urban transit buses cost considerably more, since they are required to operate continuously at high flow rates during refuelling times at the end of operational shifts. A facility recently constructed in Toronto to serve 100-120 buses cost approximately US\$2.5 million.

¹² Constable G.A., Gibson C.J., Gram A., "Use of LNG in Heavy-Duty Vehicles" SAE Paper 891670.

Vehicle refuelling appliances will reduce the consumer's concern regarding the availability of public fuelling stations. Systems are also being developed to ensure more consistent filling of vehicle storage cylinders in all temperature conditions. This is particularly important for urban transit buses and fleets of monofuel vehicles.

LNG vehicle refuelling systems are in a very early stage of development. There is no widespread component or system standardization, and it is difficult, and may be misleading, to attempt to predict costs at this stage. A primary choice is whether to liquefy the fuel in small quantities where the vehicles are actually refuelling, or to deliver LNG to the fuel stations from large centralized liquefaction plants. There is an enormous amount of experience available regarding large scale production, storage and transport of LNG. The work to be done involves adapting the equipment and technologies used to a scale commensurate with fuelling vehicles. There is no fundamental technical objection to fuelling vehicles with LNG, but only time and practical experience will allow discovery and solution of the detail problems involved.

IV ON BOARD VEHICLE STORAGE

A. CURRENT TECHNOLOGY

There are three possible ways in which to store natural gas on board vehicles, high pressure compression, cryogenic liquefaction and adsorption in a porous medium. Virtually all current vehicles use compressed gas storage, at a working pressure of 20 MPa. Only a few experimental vehicles are using liquefied natural gas (LNG). Adsorption has not yet been used on a working vehicle. Steel high pressure cylinders, similar to those found in many industrial applications, are used in about 90% of vehicles. The twin problems associated with gas compression as a method of fuel storage are volume and weight. To store an equivalent amount of energy occupies between 3 and 4 times as much volume as gasoline or diesel. In addition, the weight of the cylinder or cylinders required to contain the gas is considerably greater than the weight of an ordinary steel or plastic tank to contain the equivalent amount of liquid fuel. The potential range of a natural gas vehicle is therefore typically 30% to 40% less than that of a similar gasoline or diesel vehicle. Some converted buses weigh approximately 1,200 kg more than the standard diesel versions in order to retain comparable operating range. Steel cylinders are now being superseded by lightweight construction cylinders consisting of a thin inner shell reinforced by outer windings of fibreglass or similar high strength fibre. This goes some way towards minimizing the weight increase, but the volume requirement may only be reduced by raising the storage pressure. This is perfectly possible from the technical aspect, and equipment suitable for pressures up to 30 MPa is available. However, the stored energy density does not increase in a direct relationship to the pressure. The weight and cost of cylinders is significantly more. Furthermore, the cost of gas compression to a higher working pressure goes up rapidly, because of the extra capital cost of the compressor plant, and the non linear increase in electrical or other energy needed to power the compressor. All of these factors combine against any change in the working pressure of a CNG system. Nonetheless, vehicle manufacturers in North America are promoting storage at 24MPa to improve the range of vehicles.

Compressed gas storage has proved to be a reliable and safe technology. It is estimated that between five and eight million natural gas storage cylinders have been used in vehicles since the second World War. As far as is known no accidents involving human injury or death have been specifically attributed to cylinder failure.

COMPRESSED GAS STORAGE

Steel Cylinders

The advantages of steel cylinders include ready availability at competitive prices, and acceptance by national safety codes. There are some variations of detail in the construction and safety requirements between countries. However, almost all industrialized countries have long-established steel cylinder production plants, and the differences in national safety codes are not great enough to prevent considerable export and import traffic. Steel cylinders are safe, strong enough to withstand the shocks and vibration of vehicle use, and have been successfully used for over 50 years to store natural gas on vehicles. In addition, the valves and fittings necessary to connect the cylinders to the vehicle fuel system are also made to standard specifications and are widely available.

The great disadvantage of steel cylinders for vehicle use is weight. Steel cylinders weigh between 0.9 kg and 1.2 kg per litre of storage volume, depending upon the configuration of the individual cylinder and the specification to which it is manufactured. In addition, the range of cylinder sizes and shapes is fairly limited, so that it is sometimes difficult to find cylinders which make the best use of the space available for fuel storage on board a vehicle. Steel cylinders for vehicles are normally produced in sizes up to 130 L.

Hoop and Fully Wrapped Cylinders

A wrapped cylinder is a thin walled metal cylinder, which is made strong enough to resist high pressures by wrapping it with resin bonded fibre filament. Most wrapped cylinders currently used on vehicles are made of steel or aluminum, wrapped in glass fibre. High strength Kevlar or graphite fibres may be used, but the extra cost involved does not appear to be justified for normal vehicle service. The wrapping is bonded to the cylinder with a polymeric resin. Two types of cylinders are possible. Cylinders having reinforcing wrapping around the walls only are referred to as "hoop wrapped". This type of wrapping can be carried out with fairly simple machinery at reasonable cost. The metal thickness is usually increased for the cylinder end caps, so that no reinforcing wrapping is needed at the ends, and a screw thread may be cut to fit a control valve. The other type of cylinder is "fully wrapped" to reduce weight further but at higher cost relative to hoop wrapped. The Australians have recently developed a welded steel liner, fully wrapped, to minimize production costs.

Metal/fibreglass cylinders have the same pressure capabilities as all steel cylinders, but weigh approximately 25% less. They are more costly than plain steel cylinders, and are starting to gain regulatory approval. The range of

wrapped cylinder sizes and shapes is restricted, depending upon the basic metal tube stock diameters available. The long term fatigue stress resistance depends on the design. The winding process is designed to put a compressive pre-stress into the metal cylinder, so that working stresses in the metal tend to alternate around a zero level instead of being constantly positive. This is an important consideration for vehicle use, where it is not uncommon for cylinders to alternate between full and empty every day. Metal/fibreglass cylinders suitable for storing natural gas on vehicles are available in sizes up to 400 L.

Composite Cylinders

Composite construction is a logical progression of the wrapped cylinder principle, in which the metal inner cylinder is replaced by a thin plastic liner. The plastic liner simply acts as an impervious skin in which to contain the gas, and cylinder strength and resistance to pressure is derived entirely from the fibre filament wrapping. A steel insert is placed at one end of the liner to allow screw fitting of a valve. This type of cylinder has been used for some time in military and aerospace applications, and is also popular for portable breathing apparatus such as scuba diving and fire-fighting equipment.

In this type of construction, the wrapping has to be carried over the ends of the cylinder, and the cylinder is therefore fully wrapped. The machinery required is much more complicated than that necessary to perform hoop wrapping, and manufacturing cost tends to rise accordingly. However, the advantage is that composite cylinders may easily be produced in a wide range of shapes and sizes, allowing custom design to fit particular types of vehicle. This means that more natural gas storage space can be provided on a given vehicle than if the designer is obliged to use standard size steel or wrapped cylinders.

Composite construction provides the lightest high pressure gas storage cylinders currently available. A typical 70 L carbon fibre composite cylinder weighs about 38 kg. A steel cylinder of similar capacity weighs approximately 75 kg. Other advantages include elimination of external and internal corrosion, and high resistance to fatigue failure. A unique advantage is the mode of failure. Over pressurization eventually causes separation of the windings, and the gas escapes through the splits formed in the cylinder walls. The fibres do not rupture catastrophically, and the cylinder remains in one piece, as required by all cylinder safety codes. In the event of a fire, the resin bonding softens, so that wall failure occurs at a lower pressure, and the gas can burn off through wall splits instead of building up to an explosive pressure. This inherently "fail safe" characteristic introduces the possibility of using composite cylinders without separate pressure relief valves, so saving on cost and complication, and increasing the overall reliability of a vehicle fuel system.

There are a number of disadvantages, the first being that composite cylinders are not at present accepted for general use in natural gas vehicles in several countries. In areas where they are permitted, production is usually limited and prices tend to be high. Composite cylinders may be expected to be less affected by corrosion and water content of gases than metal cylinders, but their strength is dependent upon the chemical stability of the resin bonding the fibre windings. Their main problem is exposure to ultraviolet light which can be overcome with appropriate coatings. Their resistance to impact and penetration is less than that of an all steel cylinder.

The advantages of composite cylinders generally outweigh the disadvantages, and this type of cylinder is expected to become the most popular means of on-board gas storage in the medium term future.

Comparison of Storage Cylinder Weight and Cost

Exhibit IV-1 shows the relative weights per unit volume of gas stored for the four most common forms of cylinder construction. All types of cylinder are designed for a standard working pressure of 20 MPa. There is little variation in the weight of steel cylinders owing to widespread standardization of design. Composite designs can vary considerably in weight per stored volume, depending upon the type of fibre and resin used.

Exhibit IV-1. Comparative Weights of Storage Cylinders

Cylinder Construction	Weight per Unit Volume of gas stored (kg/litre)
Steel	0.9 to 1.2
Hoop Wrapped Steel	0.7 to 0.9
Hoop Wrapped Aluminum	0.75 to 0.8
Plastic Fibre Composite	0.4 to 0.9

At present all-steel cylinders are the cheapest available method for storing natural gas on board a vehicle. Exhibit IV-2 shows the relationships between the prices of similar capacity cylinders using different methods of construction. The price of a basic steel cylinder is taken as the baseline, and given a value of 1. The Exhibit gives current comparisons and industry predictions of future price relationships.

Exhibit IV-2. Current and Future Cylinder Price Relationships

Cylinder Material	1991 Price Comparison	1996 Price Comparison
Steel (Baseline)	1.0	1.0
Steel hoop wrapped	1.9 - 2.3	1.4 - 2.0
Aluminum hoop wrapped	2.6 - 4.3	1.8 - 2.7
Composite glass fibre	3.6 - 6.3	1.0 - 2.5
Composite carbon fibre	5.4 - 6.9	1.8 - 3.5

The cost differential between steel and other types of cylinder is expected to narrow considerably within the next five years. Factors influencing this change include anticipated increase in the acceptance of hoop wrapped and composite cylinders by regulatory authorities, increased production volumes and more efficient production methods.

Gas Adsorption

Natural gas may be adsorbed by a high surface area material such as silica gel, activated alumina or activated carbon. The activated carbon canisters used for control of automobile evaporative emissions are an example of the principle. Several R&D projects are investigating gas adsorption. Adsorption systems are capable of storing, in a given volume, as much gas at a pressure of 2 MPa as could be stored at 9 MPa using compression only. The main advantage of adsorption is lower storage pressure, leading to simpler compressor systems, reduced costs of compression, and cheaper storage tank construction. Drawbacks include a tendency to lose storage capacity over time through material contamination, and sensitivity of adsorption rate to temperature. The design of the storage vessel and the rate at which the material can adsorb and desorb gas influences the refuelling time and the ability of the fuel system to respond to sudden demands for increased engine power. Although this storage technique is superficially very attractive there is a need for much more research and development to make it truly practical. It is unlikely to become an operational or commercial reality in the near to mid-term future.

LIQUEFIED NATURAL GAS (LNG)

Liquefied natural gas may be stored on board vehicles at -165°C , at a pressure of approximately 0.4 MPa (60 psi). Storage tanks are normally designed to withstand approximately 1 MPa (150 psi). The tanks are made of special alloy steels, generally in cylindrical shapes, with double walls

separated by a vacuum gap or insulation. Tests conducted in preparation for an Australian LNG vehicle project demonstrated that it is possible to store LNG for over a week before significant boil-off loss occurs.

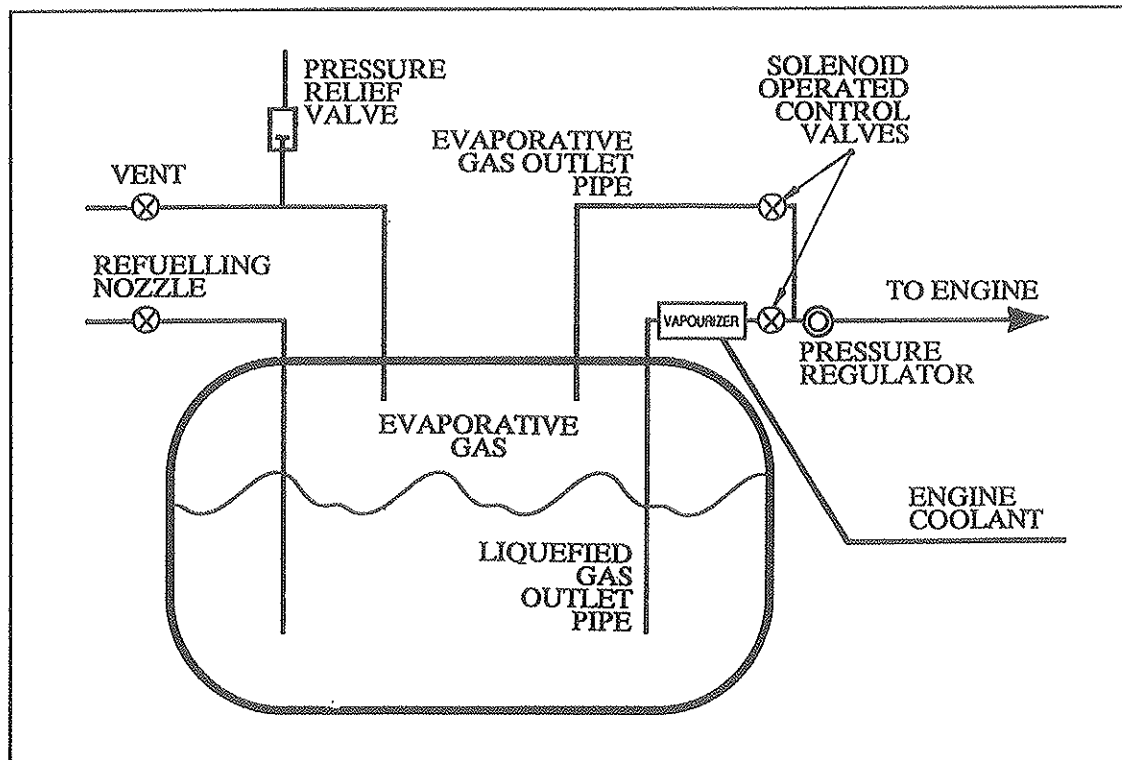

Exhibit IV-3. Liquefied Natural Gas Storage Tank

A typical LNG on-board fuel system is illustrated in Exhibit IV-3. For engine starting or low load operations sufficient fuel may be obtained in a gaseous state from the free gas space above the liquid surface. This supply, at the tank working pressure of 0.4 MPa, is led to the fuel system regulator valve, which reduces the pressure to the operating level of the engine fuel mixer. An increase in gas demand above the rate of evaporation within the tank will cause tank pressure to fall. This pressure drop is detected by a sensor, which activates a valve controlling the liquefied gas outlet from the tank. Liquefied gas then passes through a heated vapourizer, which also leads into the regulator valve, and so to the engine mixer. The liquid vapourizer circuit is capable of supplying a far greater amount of gas than the simple gas circuit, and provides the main fuel feed outlet for most operating conditions. The vapourizer is heated by the engine coolant.

Some modern gaseous fuel injection systems operate at pressures considerably above 0.4 MPa. For vehicles with this type of injection system a cryogenic pump is used to deliver the liquefied gas to the vapourizer at whatever pressure is required. The pump is normally electrically driven, and feeds the vapourizer through a non-return check valve. An accumulator is

usually provided to prevent surges in line pressure. This type of system can provide gaseous fuel to the engine at any required pressure up to 20 MPa. Higher pressures may be assisted by an increase in tank storage pressure, so reducing the pressure gradient across the pump, and hence the pump power requirement. However, this entails an appreciable increase in storage tank cost. The system cost therefore tends to be related to the pressure required.

B. STANDARDS AND CODES

Current NGV cylinder standards vary by country, and sometimes within a country. Factors accounting for the variation include:

- Degree of national familiarity with NGV on-board storage issues;
- Lack of domestic and international cooperation;
- Perceived safety concerns;
- Protection of local industries;
- Shortage of reliable fitness-for-purpose data.

A uniform international cylinder standard would assist the spread of natural gas use in the transportation field. Cylinder manufacturers would be able to produce larger volumes of cylinders to a single specification, so lowering unit costs. The free national and international traffic in cylinders would result in greater competition and lower market prices. As the market increased there would be more incentive for manufacturers to invest in the development of cylinders specifically intended for vehicles use. The International Association for Natural Gas Vehicles (IANGV) has set up a task force, with the objective of formulating a standard acceptable to the International Standards Organization (ISO) by 1992. The task force comprises members from all of the countries with large numbers of natural gas vehicles. The standard will be performance based. Acceptance will depend upon meeting criteria covering static strength, cyclic fatigue properties, resistance to ultraviolet exposure and corrosion, and other service requirements. It is hoped that the standard will encourage research into new types of cylinder and manufacturing processes, particularly in the area of lightweight composite construction.

In response to rapidly growing interest in natural gas vehicles the U.S. NGV Coalition is developing an interim cylinder standard for the U.S. only. This standard is being written in close co-operation with the IANGV task force, and it is intended that it will be superseded by the ISO standard when the latter is recognized internationally.

C. FUTURE TECHNOLOGY

High pressure compression is likely to remain the most popular method of storing gas on board vehicles for the foreseeable future. Liquefied gas use will increase, but will probably be confined to individual fleets of heavy trucks or buses. Several organizations are continuing the development of adsorption storage, but there is no indication that this technology is ready for widespread practical use in the near to medium term.

The most important trend regarding high pressure storage is the increasing use of wrapped and composite cylinders. This trend is influenced more by the current state of national regulations than by any technical considerations. The IANGV and the NGV coalition are working to rationalize standards and promote international acceptance of the newer types of storage cylinders. By framing the future cylinder standards on a performance basis they are hoping to encourage research and development of new and original materials and methods of construction. When the new standards are accepted, the way will be open for a widespread move to lightweight cylinders. This should result in a cycle of increased production volume and more efficient production techniques, leading to a drop in prices, resulting in even more widespread use. It is expected that this will allow the prices of lightweight cylinders to become competitive with traditional steel cylinders, at which point there will be little reason to continue using steel cylinders. The use of lightweight cylinders may still not provide average vehicle ranges comparable to the norms expected with gasoline or diesel, however.

Liquefied natural gas storage is technically very close to ready for large scale use in vehicles. It is not difficult to provide equal vehicle range to diesel or gasoline using liquefied storage. Most trucks and buses have sufficient space available on board to accommodate the 50% greater fuel volume required. Suitable storage tanks are available, and the technique of handling liquefied natural gas in bulk is very well researched and understood. The major limitations will be the commercial availability of liquefied gas in quantities suitable for vehicle use, and its acceptance by health and safety regulations, fleet management and worker organizations. As the number of heavy duty natural gas vehicles in service increases, it is expected that a significant proportion of fleets will elect to use LNG, resulting in a similar cycle of increased production and lowering of component costs as mentioned in conjunction with lightweight high pressure cylinders. It is not expected that LNG will penetrate into the private vehicle and general user market, due to the greater complication of the equipment, and the need to store fuel for longer periods between refuelling. However, LNG has obvious attractions in countries which import large quantities of gas in the liquefied state, such as Japan. In these countries, LNG use in vehicles is expected to become more widespread than in countries where natural gas is normally transmitted and used in the gaseous state.

Adsorption is likely to remain theoretically attractive but impractical for actual vehicle service. There is a distinct possibility that a practical method of adsorptive storage will arrive too late to capture any share of the on board storage market. The natural gas vehicle movement urgently needs to expand the fuelling station network, and the preferred fuel system technology is pressurized storage at 20 MPa. Any "non standard" method already stands at a distinct disadvantage, which will only increase as the number of CNG refuelling stations grows. Unless some economical means of adapting CNG refuelling to allow for the lower pressures and other changes associated with adsorption is developed, it is unlikely that this technology will be used to any degree in the future.

D. SUMMARY

There are three feasible methods for storing natural gas fuel on board a vehicle; compression, liquefaction, and adsorption. Almost all natural gas vehicles built store the fuel in cylinders pressurized to approximately 20 MPa (3,000psi). Most storage cylinders are made of steel, to specifications developed for industrial uses. This type of cylinder is extremely safe and durable, but very heavy for use in vehicles. Lighter weight cylinders, consisting of thin metal or plastic liners reinforced with glass fibre windings, are being used in increasing numbers.

High pressure compression will remain the most popular method for storing gas on board vehicles for the foreseeable future. The all steel cylinder is likely to be superseded by fibre reinforced metal (wrapped) and all composite cylinders. At present not all countries will allow the use of the newer types of cylinder. It is expected that regulations will be altered to permit wrapped and composite cylinders as operating experience increases and a safety record is established. In order to speed the international acceptance of all types of cylinders, the IANGV is promulgating a cylinder standard which is expected to be endorsed by the International Standards Organization.

The standard storage pressure is likely to remain at 20 MPa, because of the escalation of costs associated with any significant increase. Nonetheless, vehicle manufacturers in North America are promoting storage at 24MPa to improve the driving range of vehicles.

Liquefied natural gas storage requires approximately 50% more fuel volume than diesel or gasoline to give the same vehicle range. Many trucks and buses have this extra space available, and LNG can therefore provide equal range to diesel. The weight of LNG tanks and auxiliary equipment is less than the weight of compressed gas cylinders. LNG has many advantages for heavy vehicle use, and several experimental trucks and buses are currently in

operation. It is unlikely to be used in passenger cars and light vehicles, except in countries which import and use large quantities of gas in the liquid state, such as Japan.

Adsorption allows storage of equal quantities of gas at pressures about an order of magnitude less than required for storage by compression alone. However, there are a number of practical difficulties to be overcome, and adsorptive storage has not yet been used in a practical vehicle.

V LIGHT DUTY VEHICLE UTILIZATION

A. CURRENT VEHICLES AND TECHNOLOGY

The great majority of natural gas vehicles in service today are cars and light duty vans or trucks, using bi-fuel conversions of gasoline engines. The term "bi-fuel" denotes an engine capable of running on gasoline (or diesel) or natural gas, so that the vehicle can operate satisfactorily when natural gas is not available.

The largest populations of natural gas vehicles are in Italy, Argentina and New Zealand. Russia and several of the other ex-Soviet states are also known to have large numbers of vehicles, but the exact quantities are not easily confirmed. All of these countries have less stringent restrictions on exhaust emissions than the U.S.A., Canada, Sweden and Japan. In addition the average age of the vehicle stock tends to be higher. Because of this, the technology in use frequently does not represent the latest developments in emissions reductions or vehicle performance, although it is well proven from a serviceability and reliability aspect.

"State-of-the-art" conversion technology is primarily confined to the U.S.A., Italy, and Canada at present, using equipment which is compatible with modern electronically controlled, fuel injected gasoline engines. These conversions provide excellent all-round performance, and emissions levels in compliance with current regulations.

The highest levels of performance and emissions reductions may only be achieved with engines designed to run exclusively on natural gas. Development of this type of engine is well underway in Japan, Sweden, U.S.A., and several other countries. There is no engineering or technical impediment to the use of such engines, and several designs are ready for production. However, introduction into practical applications has been inhibited by the restricted availability of fuel. This situation is changing, and several thousand monofuel natural gas light vehicles are currently being produced for markets in the U.S.A. by General Motors, Ford and Chrysler.

The most common worldwide method of storing the natural gas on the vehicle is in steel cylinders pressurized to 20 MPa. Composite construction storage cylinders are becoming more popular. These greatly reduce the weight penalty associated with steel cylinders, and are available in a greater variety of shapes and sizes. These features can help to increase fuel storage capacity, and hence vehicle range. They have been shown to be as safe and reliable as steel cylinders in laboratory tests and actual vehicle operations.

1. MARKET PENETRATION

At least 40 countries around the world have natural gas vehicles in operation, or have made official declarations of their intention to undertake NGV programs. Exhibit V-1 provides a summary of countries known to have programs of more than 500 vehicles in operation. The great majority of these are light vehicles, converted from gasoline operation. The number of heavy duty vehicles with converted diesel engines is small at present. The figure for fuelling stations refers to all types, not all of which are available to the general public.

Exhibit V-1. Major World NGV Populations¹³

Country	Gasoline Vehicles	Diesel Vehicles	Fuelling Stations
Russia etc.	315,000	NR	339
Italy	235,000	20	240
Argentina	100,000	10	125
New Zealand	50,000	65	350
U.S.A.	30,000	NR	328
Canada	26,000	25	173
Malaysia	1,100	0	7
Brazil	400	300	7
Australia	514	112	10
NR = Not Reported			

Russia and Commonwealth States

The independent commonwealth states have about 315,000 NGVs of all types in service.¹⁴ Early NGV developments were concentrated in the Ukraine and Volga regions, where about 25,000 converted vehicles were in operation as far back as 1950. The Soviet government officially endorsed a program for the use of natural gas in automotive transport in 1981. The NGV population is expanding at a steady rate. It is claimed that the recent political events will

¹³ International Association for Natural Gas Vehicles (IANGV), Newsletter No. 20, September 1991.

¹⁴ GASPROM, U.S.S.R., "Substitution of Liquid for Gaseous Fuels in the Soviet Union", Paper No. 38 presented to the IANGV Conference "NGV90" Buenos Aires, October 1990.

not affect the program, and current plans anticipate close to 2 million vehicles not long after the year 2000. Russia contains about half of the known world natural gas reserves, and supplies large quantities to several European countries through an extensive pipeline network. Within its own borders, gas is piped throughout all of European Russia, and much of the Urals and Central Asia. In 1990, there were 339 NGV refueling stations in 242 cities and towns.

Extensive research into the problem of supply to remote areas has been undertaken, which has resulted in a system of truck semi-trailers carrying gas at pressures up to 30 MPa. These are filled at central compressor stations and then transported by road or rail to communities not supplied by pipeline. They are also used to level demand peaks and provide emergency back-up supplies, so avoiding the need for excess compressor capacity. Each unit consists of a storage tank and gas dispensing equipment. They may be used singly, or connected in cascade in locations where large volumes of gas are required. The high charge pressure permits delivery of up to 70% of the stored gas into vehicle tanks operating at 20 MPa. When the pressure becomes too low to fill vehicles the remainder of the gas is frequently fed into domestic or industrial systems using lower working pressures.

All necessary equipment, including vehicle conversion kits, compressors, fuel dispensers, cylinders and transporters is manufactured locally. Equipment design is generally based on well proven prototypes developed originally in Italy. The range of conversion equipment covers 13 types of automobile, three models of truck, and one transit bus design. All are bi-fuel conversions. The price of natural gas is reported to be between 25% and 50% of that of gasoline.

Italy

Italian experience with NGV dates back to before World War II. In 1950, 6% of automobiles and 2% of trucks and buses in Italy ran on natural gas.¹⁵ There were some 1,500 fuelling stations, and numerous suppliers of conversion, compression and storage equipment, several of which have subsequently become world leaders in NGV technology. Not all of the fuelling stations had compressors. Many were only cylinder exchange points, since a popular method of refuelling at the time was to physically remove the empty cylinder from the vehicle and exchange it for a full one, as is sometimes done with LPG powered vehicles and equipment today.

¹⁵ P.Vettori, M.Branda, Federmetano-SNAM, "Italian Experience in GNC Distribution and Application", Paper No. 16 presented to the IANGV Conference "NGV90" Buenos Aires, October 1990.

Natural gas use in vehicles declined steeply during the 1960's. By 1965 only 125 fuel sales outlets remained. However, the world petroleum shortages of 1973 and 1978 reactivated the national interest, and natural gas quickly became popular again. In 1976 over 326 million cubic metres of gas was supplied to more than 300,000 vehicles, a record which has not been exceeded since. A second downturn occurred following a heavy increase in taxes on natural gas in the late 1970's. In addition, growing national prosperity reduced public tolerance for the inconveniences of vehicle range and fuel supply associated with natural gas. LPG and diesel increased in popularity as natural gas use declined.

Recently, interest in natural gas has risen again, strengthened by concern about the environmental effects of exhaust emissions, and strategic energy supplies. Natural gas is once again much cheaper than gasoline or diesel. In 1990, the price of natural gas was approximately 26% of the price of gasoline, and around 50% of the price of diesel. These price differentials provide a powerful incentive to switch from petroleum fuels. Italian natural gas suppliers are working hard to foster this revival. New conversion kits compatible with computer engine control systems and catalytic exhaust emissions control are now available. The industry is pressing for simplification of the regulations governing fuelling stations to permit quicker expansion of the supply network. It is also suggesting that low-pollution natural gas vehicles be allowed into restricted city centre areas.

New Zealand

New Zealand has had large numbers of natural gas fuelled vehicles on its roads for over 10 years. For example, the city of Palmerston has been operating most of its municipal fleet of approximately 250 cars, trucks, and buses on natural gas since 1980.^{16,17} New Zealand developed a considerable market for privately owned natural gas vehicles by providing generous tax advantages on natural gas fuel and vehicle conversions during the period from 1984 to 1986. This policy was directed at reducing imports of oil, and increasing the use of large deposits of natural gas. In 1985 around 10% of vehicles on the North Island were running on natural gas, and 5,000 conversions were carried out every month. The number of converted vehicles reached approximately 110,000. In 1986 the government abruptly withdrew all financial and promotional support for the natural gas program, in response to an urgent need to reduce budget expenditure. The NGV movement declined rapidly, weakened even more by stable or slightly

¹⁶ L.E.Shilton, "Introducing Natural Gas into a Large City Bus Fleet", Paper No. 23 presented to the IANGV Conference "NGV 90" Buenos Aires, October 1990.

¹⁷ R.R. Raine, J.S. McFeaters et al., "New Zealand Experience with Natural Gas Refuelling of Heavy Transport Engines", University of Auckland, SAE Technical Paper 892136.

declining gasoline prices, and rising natural gas prices caused by the renegotiation of major supply contracts. Natural gas vehicles lost their attraction, and a considerable percentage of their resale value. Many owners removed the conversion kits and returned to gasoline only. By 1989 the number of converted vehicles had slumped to around 45,000. The NGV industry is attempting to stem the tide by stressing that the cost of natural gas fuel is still only around 65% of that of gasoline. However, the capital incentives for new conversions of vehicles and expansion of the fuel station network have vanished, and the whole market situation has been poisoned by an atmosphere of distrust and uncertainty which does not help the attempts to reverse the decline and re-establish growth of NGV use. A recent market survey has estimated that the sustainable population of NGVs may be in the 80,000 range, based on the duty cycles and the balance between capital costs and realizable fuel cost savings.

Argentina

Argentina has pursued a policy of encouragement of NGVs since 1984. Actual conversions, estimated at 86,000 by the end of 1990, have run well ahead of the originally planned figure of 48,500. The target is 134,000 conversions and 270 operating fuel stations by 1995. The current indications are that this figure should be easily achieved.¹⁸

Exhibit V-2 illustrates the growth of the natural gas vehicle population in Argentina since 1985.

Exhibit V-2. Natural Gas Vehicles in Argentina

Year	1985	1986	1987	1988	1989	1990
Vehicles	2,065	5,442	13,313	27,565	47,434	86,000

The primary aim of the NGV program is to reduce the use of petroleum, but the country is well aware of the potential emissions benefits, and anticipates considerable air quality improvements as a result of the growing numbers of natural gas cars and buses. Argentina has built up a sizeable indigenous NGV equipment supply industry, including companies acting as agents for international compressor station and conversion kit manufacturers. 75% of the vehicle cylinders supplied are manufactured in Argentina. Most conversions to date are of the conventional after-market bi-fuel type.

¹⁸ "Prensa Vehicular", Special Edition published in conjunction with the IANGV Conference "NGV90", Buenos Aires, October 15, 1990.

However, a number of major European car manufacturers, including Fiat-Peugeot and Renault, build large numbers of cars in Argentina. Both of these companies have announced their intention to provide factory original equipment natural gas cars in the near future. These will still be bi-fuel vehicles, not dedicated monofuel.

U.S.A.

More than 30,000 natural gas vehicles are operating in the U.S.A. at the present time. The gas utility companies are promoting the expansion of the market by providing grants to manufacturers to develop NGVs. Ford, Chrysler and General Motors are each scheduled to offer vehicles for sale in 1992. These will be converted by third party contractors after they come off of the production line, but they will be fully backed by the factories and carry the same warranty as a gasoline vehicle. Vehicles actually built in the factory production lines are not expected until 1993 or 1994. The vehicles to be offered are light vans and trucks, most of which will be purchased by the natural gas utilities for use in their own fleets. A number of government bodies, such as the South Coast Air Quality Management District in California, will take some of them for evaluation purposes.

General Motors is planning to produce 3,000 pick up trucks in 1992, rising to 10,000 per year on a factory assembly line from 1993 onwards. Chrysler will output 2,000 vans in late 1992 and the early part of 1993, with full scale production scheduled for 1994. Ford anticipates building at least 200 pick up trucks by 1993, and approximately 30 large cars. Ford has not committed to definite production plans as yet. Other manufacturers supplying the U.S. market are developing vehicles, but as yet have not announced plans for production and marketing.

Natural gas fuel can be obtained at nearly 300 locations spread throughout 36 states, although some are private fleet installations, and not generally available for public use.

As yet, the NGV marketing effort has not made extensive inroads into the private and commercial sector. The 1990 Clean Air Act Amendments are expected to increase sales to the commercial fleet sector in the near to medium term future. Provisions in the clean Air Act require certain percentages of "clean fuel" vehicles in fleets above a specified minimum number of vehicles. The availability of vehicles produced and fully backed by recognized major manufacturers, as opposed to after-market conversions, is expected to boost the confidence of consumers in natural gas vehicles.

Examples of current programs in the U.S.A. include 15 small buses used for transporting handicapped persons in Austin, Texas. Public Service Company of Colorado has 313 bi-fuel NGVs. Pacific Gas & Electric Co. has 200

vehicles operating in northern and central California, and plans to convert 200 more in the near future. It also supplies gas to a U.S. Postal Service fleet of 100 vehicles.

Northern Indiana Public Service Company (NIPSCO) compiled a summary of NGVs in the Mid-Western States, which showed approximately 3,000 vehicles currently operating. Nearly all are owned by gas supply companies.

Brooklyn Union Gas is a leader in U.S. NGV advancement. The company distributes natural gas over a wide area of suburban New York, and is involved in both light and heavy vehicle development programs. It has converted over 200 of its own fleet of service vehicles to bi-fuel, and also began operating 12 dedicated natural gas vans during 1990. It is currently planning to open a network of 20 natural gas fuelling stations within its service area.

Japan

In 1990, there were 29 converted gasoline vehicles in Japan, operated by the Tokyo, Osaka and Toho gas companies. By the end of 1991 approximately 50 more NGVs were expected to be in service, including some dedicated monofuel conversions. Four quick fill stations and one slow fill station are in use, and another station is to be constructed shortly. Japanese regulations for all types of vehicle refuelling stations are exceptionally strict, and expansion of the natural gas fuelling network in urban areas is more difficult than in other countries. The Ministry of International Trade and Industry (MITI) and the Japan Gas Association (JGA) began a joint three year project in 1990 to promote the use of NGVs in Japan. Natural gas fuel is seen as a way to reduce urban pollution, and there are plans to put several thousand cars and light and heavy trucks into service by the year 2000.

Malaysia

Malaysia has recently undertaken a commercial program in Kuala Lumpur aimed at converting 1100 light duty vehicles, primarily taxi cabs. The program is being conducted by PETRONAS, the state owned oil and gas company. One "mother" and six "daughter" refuelling stations are involved in the program.

Canada

About 26,000 Canadian vehicles have been converted to operate on natural gas. Exhibit V-3 gives a breakdown of distribution by province, and the numbers of fuelling stations available.

Conversion programs in Canada were slowed for a period during 1991 by a shortage of fuel storage cylinders. Domestic production capacity cannot fulfill all requirements, and a backlog of import orders developed. At present only steel cylinders are approved for use.

Exhibit V-3. Natural Gas Vehicles in Canada

Province	Vehicles Converted	Public Fueling Stations	Private Fueling Stations
British Columbia	10,975	46	6
Alberta	656	1	19
Saskatchewan	16	0	1
Manitoba	69	0	2
Ontario	9,675	43	17
Quebec	4,680	21	5
Total	26,071	111	50

(Source: CGA NGV Development Office, December 1990.)

Most Canadian communities of any size are served by a natural gas pipeline, and a high proportion of Canadian homes are heated by natural gas. This situation provides a great opportunity for the promotion of home refuelling appliances, which has been taken up by regional gas utility companies. Production and supply facilities have been established in British Columbia. Over 500 units are in service, primarily in Ontario and Alberta. These self-contained refuelling appliances are very practical for small fleets as well as the domestic customer. They can also provide an excellent way for a fleet of any size to test a few natural gas vehicles without the major capital expenditure associated with a large scale compressor station.

Holland

Holland only began serious investigation of natural gas vehicles about 8 years ago. This is remarkable, since the country has ample national reserves of natural gas, and has had for many years a supply network reaching well over 90% of its inhabitants. Holland is also well adjusted to the concept of alternative fuels, with approximately 700,000 propane vehicles in operation. GCN, a major gas utility company, and TNO, a prominent engine research organization, have jointly undertaken NGV development and promotion work. By 1991 approximately 150 light vehicles with converted bi-fuel

engines were in service. In common with other countries, Holland is looking to dedicated monofuel vehicles as soon as there is an adequate network of fuelling stations in place to service them. At present there are about 20 fuelling facilities of various types and sizes available. As the numbers of vehicles have increased, other gas utilities and vehicle and equipment suppliers have joined in the development programs. Cars with engines as small as 1.1 L have successfully been converted, and the majority of natural gas vehicles have engines below 2 L capacity. Holland plans to have 1,000 NGVs on the road by 1995.

Germany

Germany does not give favorable tax treatment to natural gas used as a vehicle fuel. The incentive to develop natural gas vehicles is therefore much reduced. Only five vehicles fuelled by CNG are in service in Germany. Four were converted to dual-fuel operation in 1984 by the Ruhrgas AG utility, and have operated since then in the Baden-Wurtemberg area. Volkswagen and BMW are known to have undertaken research on natural gas engines, but neither company has released any details of its work.

Belgium

In Belgium 35 light vans had been converted to natural gas operation by the end of 1991. Gas is supplied by 9 "Fuelmaker" home compressor units, and a Sulzer compressor station with a capacity of 170 cubic metres per hour. A new company called "CITENSY" has been created to market NGVs to gas utilities, municipalities, waste handling companies and city transit companies.

United Kingdom

Approximately 30 gasoline engine light vehicles have been converted to natural gas to date. There are 3 fast fill refuelling stations in operation, in London, Birmingham and Blackburn, and 12 "Fuelmaker" home refuelling appliances have been purchased for demonstration purposes.

British Gas plans to spend approximately £1,000,000 during 1992 to promote development of natural gas vehicles and associated technology. 70 gasoline vehicles and 8 diesel trucks will be converted to dual fuel operation. Each fleet will be provided with a fast fill refuelling station. Several other similar projects currently in the planning stage are expected to be operational by 1993. British Gas is also conducting an extensive NGV marketing campaign aimed at the government and major British fleet operators.

Switzerland

Switzerland has converted 10 Renault light vans to natural gas since 1990. The Swiss Federal Polytechnical University of Lausanne is undertaking development and performance optimization of the test fleet with the objective of obtaining official certification of a conversion kit.

Other Countries

Most other countries experimenting with NGVs are primarily seeking substitutes for imported oil. Many of them, such as India, Pakistan and Tanzania, have large unexploited deposits of natural gas. The prospect of using NGVs is therefore very attractive economically. New Zealand and Australia are making vigorous efforts to export their experience and technology to these countries, and several of them now have a handful of converted vehicles on the road. All use conventional carburetted bi-fuel conversions at present.

2. TECHNOLOGY USED

Most NGVs in current use are after-market conversions of gasoline vehicles. The bi-fuel natural gas/gasoline concept consists of fitting the engine with a natural gas carburetor (generally called a gas/air mixer) in addition to the regular gasoline carburetor or fuel injection system. The vehicle thus retains the ability to run on gasoline, but the disadvantage is that the engine performance is not optimized for either fuel. In an international context most NGV users are concerned with lower fuel costs. Users have been prepared to sacrifice some degree of engine power and performance for the savings available. Exhaust emissions output has not been regarded as important until very recently. Consequently a simple and reliable, but relatively unsophisticated, conversion system has fulfilled the requirements of the market.

When using natural gas, the gasoline supply to the fuel system is shut off, and substituted by gas fed into the venturi of the gas/air mixer at just above atmospheric pressure. The natural gas and air mixture is subsequently drawn into the engine and fired by the spark plugs exactly as for gasoline operation. For optimum performance, a number of further refinements are desirable, including more advanced spark timing, to allow for the lower flame speed of the gas/air mixture, and maintenance of a low inlet air temperature to minimize the volumetric efficiency loss due to the volume of the gas itself. Raising the compression ratio to exploit the higher octane rating of NGV (approximately 130 RON), can increase engine fuel efficiency and power output. Most conversions to date have not incorporated these features, because of the extra cost and complication involved.

The components of a conventional carburetted natural gas conversion kit for a gasoline engine include:

- Gas Storage Cylinder(s);
- Fuel Selector Switch;
- Pressure Regulator;
- Fuel Gauge Transducer and Fuel Gauge;
- Cylinder Master Shut-Off Valve;
- Gas Refuelling Connection;
- Air-Fuel Carburetor or Mixer;
- Dual Curve Ignition Control Box;
- Gasoline Solenoid Control Valve;
- Pressure Lines and Fittings;
- Pressure Relief System.

A typical gasoline engine conversion schematic is illustrated in Exhibit V-4.

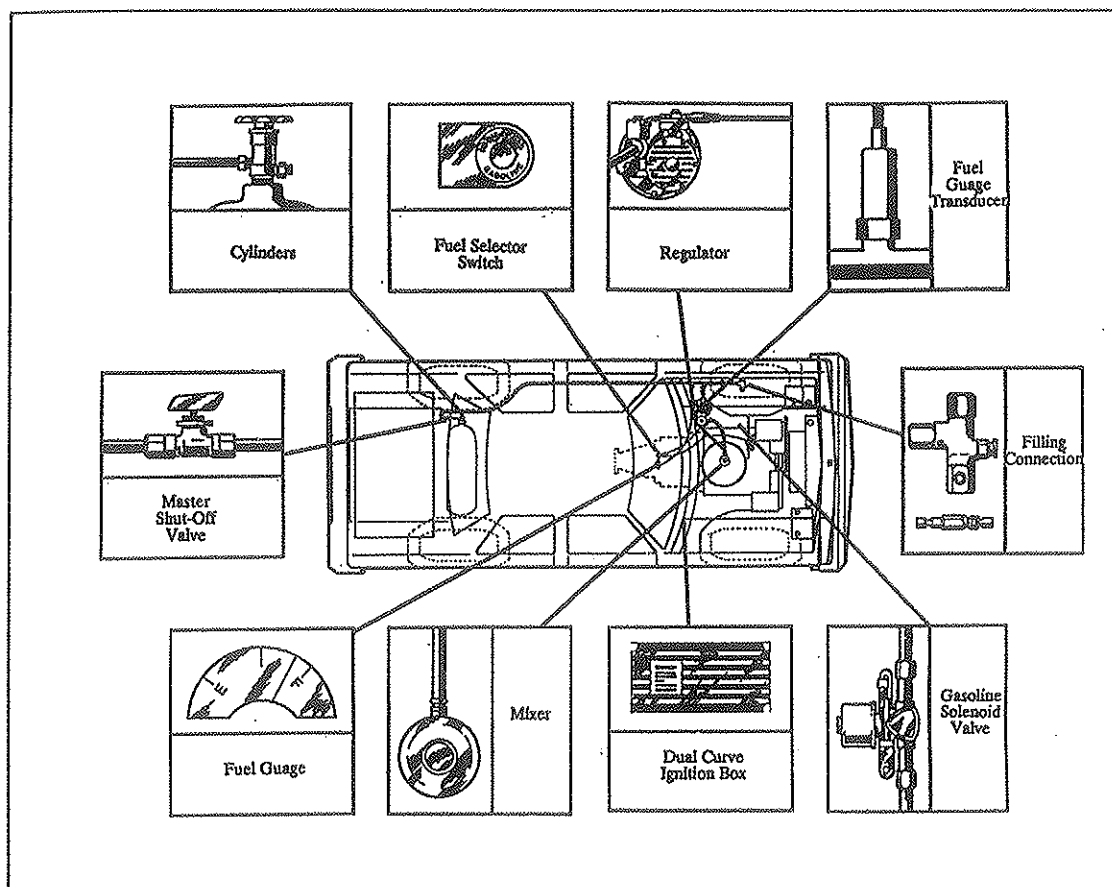

Exhibit V-4. Schematic of Gasoline Engine Conversion Kit

Gas Storage Cylinders

Cylinders are available in a number of standard sizes. A 50 L cylinder holds sufficient natural gas to give a mid-size car a range of approximately 140 km. A typical car conversion uses two 50 L cylinders, while light trucks and vans normally require four to six cylinders in order to provide adequate range.

The cylinders are usually fitted in the luggage compartment, immediately behind the rear seat pressing in a normal passenger car. The "pick-up" style of light truck is particularly adaptable to installation of gas cylinders. In many applications the load carrying body is seldom filled to capacity, and one large or multiple smaller cylinders may be fitted inside the body, immediately behind the driving cab, with minimal inconvenience. Trucks may also have the cylinders mounted along the frame rails, as is normal for gasoline or diesel tanks. Light vans may be equipped in similar fashion.

The cylinders must be mounted securely in place, and regulations provide for local reinforcement of the vehicle bodywork where the locating brackets are fastened.

Fuel Selector Switch

The fuel selector switch is mounted on the vehicle dashboard. The driver may switch from one fuel to another at any time without stopping the engine or vehicle. The switch does not directly interrupt the natural gas supply, but is connected to a solenoid controlling the manifold vacuum signal to the gas control valve in the regulator assembly. This ensures that manifold vacuum maintains the overriding control over gas delivery, so avoiding accidental release of gas while the engine is not operating. If the engine has a gasoline carburetor and mechanical fuel pump the gasoline supply is controlled by a solenoid operated shut-off valve in the fuel line. For fuel injected systems it is necessary to provide an electronic interface with the injector controller to disable operation of the injectors during periods of natural gas operation.

Pressure Regulator

The necessary pressure reduction is usually achieved in two or three stages. A typical modern system manufactured by IMPCO uses two stages of regulation, the first dropping pressure down to 0.6 MPa from the 20 MPa storage level. The regulator assembly is heated by engine coolant to offset the temperature drop produced by the considerable pressure gradient across the reducer valve. Gas from this primary reduction stage next passes through a vacuum controlled shut-off valve, which positively stops gas flow until vacuum is present in the engine inlet manifold. This unit also incorporates a

fuel filter. The next stage is the secondary reduction valve which drops pressure to between 490 Pa and 1,600 Pa, which is the working range for the air-fuel mixer.

Fuel Gauge Transducer and Fuel Gauge

The pressure in the gas storage cylinders is monitored to indicate the amount of fuel remaining. The pressure transducer is located in the high pressure supply just ahead of the first stage regulator. It usually forms part of the complete pressure regulator assembly. The transducer produces an electrical signal which controls a dashboard gauge similar to a conventional gasoline level gauge.

Cylinder Master Shut-Off Valve

A master shut-off valve is fitted in the high pressure gas supply line immediately adjacent to the cylinder outlet. This allows the gas supply to be shut off at source if a leak is detected, or for system servicing. If more than one cylinder is used, the master shut-off valve is located in the high pressure outlet manifold, controlling the flow from all cylinders.

Gas Refuelling Connection

The refuelling connection is the one way valve through which the vehicle storage cylinders are replenished. It is installed in the high pressure piping ahead of the first stage regulator. It is usually located in the engine compartment of the vehicle, meaning that the operator must raise the hood in order to refuel. A number of different designs are in use in various countries, but the general principle involves a probe on the end of the natural gas dispenser line, which must be positively locked into the refuelling connector before gas will flow. The fill block also provides a mechanism for release of the system pressure before the probe can be removed after fuelling, in order to avoid any blow-back effect.

Air-Fuel Carburetor or Mixer

The Air-Fuel Carburetor or Mixer is installed on the engine induction manifold, ahead of the gasoline carburetor or fuel injectors, according to vehicle design. A typical mixer feeds gas at slightly above atmospheric pressure into the inlet air stream through a series of small holes drilled around the periphery of the venturi. The mixer does not have any throttle plate, or auxiliary fuel jet circuits. Engine control continues to be by the original throttle butterfly valve and accelerator pedal linkage. The gas/air mixer is capable of apportioning gas input according to the air flow through the gasoline system butterfly valve, and requires no mechanical linkage or idle vacuum connection to function.

Dual Curve Ignition Control Box

It is desirable to advance the ignition timing in order to compensate for the lower flame propagation speed of natural gas. This was not easily arranged when converting an engine with an old style distributor and centrifugal advance system. Modern conversions of engines with computer control systems incorporate an ignition advance control box. This provides dual ignition advance curves, one for operation on natural gas and one for operation on gasoline.

Pressure Lines and Fittings

High pressure lines are made from stainless steel or copper tubing, tested to a burst pressure of 130 MPa. The flexible low pressure lines from the second stage regulator to the air-fuel mixer may be made from rubber or polymeric material.

Pressure Relief System

For steel storage cylinders, a pressure relief valve is fitted in the high pressure line adjacent to the cylinder outlet(s). For aluminium and fibreglass composite cylinders, a fusible plug which melts at approximately 100°C is used. Over-pressurization is most commonly caused by an emergency temperature rise situation such as a vehicle fire.

Performance and Driveability

There is a noticeable loss of power when a gasoline car or truck is converted to operate on natural gas, unless the vehicle is optimized for natural gas fuelling. This occurs because the natural gas in the fuel/air mixture going to the engine displaces some of the potential air supply, and hence reduces the amount of oxygen available for combustion. The energy content of a stoichiometric natural gas/air mixture at typical temperature and pressure conditions is approximately 90% that of a stoichiometric gasoline/air mixture. All other engine features being equal, this translates into a theoretical maximum power loss of 10% when operating on natural gas.

The power loss can be regained by several measures, including modifying the engine valve timing, and induction and exhaust passages, and raising the compression ratio. Turbocharging has become widely available on gasoline engines during the last 10 years, and may be used on bi-fuel or monofuel natural gas engines to provide similar power improvements. However, these modifications are complicated and costly to implement on an existing engine. They are not usually included in ordinary bi-fuel conversions.

Drivers operating converted vehicles have often been additionally frustrated to find a small loss of power when running on gasoline as well. This is caused by the air-fuel mixer interfering with the air flow through the induction manifold and increasing the engine pumping losses.

How much of a problem this power loss may present is dependent upon the type of vehicle, its duty cycle, and the habits of the driver. The continuing improvements in conversion technology have reduced the effect considerably. The average medium to large size automobile is rarely, sometimes never, driven to the limit of its performance capabilities, so that the reduction in peak power may seldom be noticed. However, vans and trucks can be noticeably affected, especially when fully loaded.

Reports from earlier Canadian fleet trials, between 1983 and 1986, commented on the power loss problem. Generally car owners, including taxi fleets, found the loss of power noticeable but acceptable in return for the fuel cost savings obtained. Drivers of larger vehicles, with less reserve power, were more affected. The natural gas conversions were eventually removed from the heaviest vehicles in the trial group, because the drop in acceleration and gradient performance was too great. All of the vehicles involved used large capacity, relatively slow speed, gasoline engines, with low specific power outputs.

Since that time the improvements in conversion technology have done much to eliminate the problem. In Holland, the first attempts at bi-fuel conversions showed as much as 30% power loss, but careful redesign of the fuel mixer cut this figure considerably. The Dutch vehicles have small high speed engines, which are more representative of current trends in international design. On-road performance is acceptable using engines as small as 1.1 L capacity. Generally the level of performance given by modern natural gas cars and other light vehicles is so close to the original gasoline standards that reports do not need to comment on the point.

The natural gas engine theoretically offers unique advantages in cold starting. There is no need for a choke or fuel enrichment device. Fuel/air mixing is complete and homogeneous at any feasible starting temperature. Some fleet trials have reported instances of difficult starting due to freezing of the first stage pressure reducing valve. This can be caused by water or hydrates in the supply gas. The problem may be addressed by control of gas quality and preheating of the regulator in extreme conditions.

Durability and Reliability

Operators of vehicles converted to natural gas have reported that maintenance costs are no greater than for similar gasoline engines. NGVs typically give longer spark plug and exhaust system life, and the lubricating oil

remains cleaner. There is no possibility of cylinder wall lubrication washdown, as can occur with liquid fuels, particularly during cold starting. This eliminates a leading cause of premature engine wear. Neither is there any chance of dilution of the lubrication oil in the crankcase, which may be expected to reduce the chances of wear on bearings and camshafts.

Cleaner lubricating oil is widely quoted as an advantage when using natural gas. It is frequently suggested that oil change intervals may be extended because of the clean appearance of the oil. Several large scale vehicle trials have involved extensive oil sampling and analysis programs. Some of these have highlighted the fact that oil degradation involves much more than visual appearance. A Canadian taxi fleet report concluded that both gasoline and natural gas taxis may safely run up to 10,000 km between oil changes. Oil discoloration was quite noticeable on both fuels. Taxi service is not necessarily hard on engine oil, because much of the time is spent with the engine at full operating temperature, which minimizes condensation and acid formation within the engine.

One major limitation on oil life can be the silicon content, which is most affected by the efficiency of the engine air filtration system, and is unlikely to be influenced by the type of fuel. It is questionable to recommend longer oil change intervals simply because a change is made to natural gas fuel. As for gasoline, it is also important to consider the operating environment and the duty cycle of the vehicle.

Several major oil companies are conducting research into the lubrication of natural gas engines. Special oils for stationary engines have been available for many years past. The introduction of such oils into the vehicle field will be linked to the introduction of dedicated engines. In the meantime any oils used must generally be compatible with gasoline as well as natural gas fuel.

The extra weight of the fuel storage cylinders may cause increased wear of brakes, suspension and tires. Additional marginal expense may also be expected because of the additional fuel system components and the requirement to recertify fuel cylinders every five years. There are developments underway to have visual inspections only with the introduction of new performance standards.

Fuel Consumption

Union Gas Limited, in conjunction with the Ontario Ministry of Transportation and Communications, operated a mixed fleet of bi-fuel vehicles in and around the city of Hamilton from 1983 to 1985. The summary report¹⁹ provided details of the fuel consumption rates achieved by the

¹⁹ "Natural Gas Vehicle Demonstration by Union Gas" Ministry of Transportation and Communications, Ontario. Report AF-86-06.

various types of vehicles included in the project. Results were published in the form of Btu per kilometer. No average figure was given, but most vehicles returned natural gas energy based fuel consumption figures between 75% and 95% of those for gasoline, suggesting that natural gas operation was more energy efficient. A Vancouver taxi fleet trial also indicated lower natural gas energy consumption, with levels between 90% and 94% of the corresponding gasoline figures.

The University of Toronto carried out fuel consumption tests on typical first generation NGV conversion kits during 1984-86. The report²⁰ stated that energy consumption with natural gas increased under most steady-state operating conditions, but decreased under idle and transient conditions. In a particular series of tests with a Ford F150 pickup truck, an overall energy consumption increase of 2.5% was observed. This figure was a comparison between the original vehicle baseline gasoline performance, and its performance after conversion, operating in the natural gas mode. Comparison of the original baseline gasoline energy consumption, conversion (natural gas mode), and conversion (gasoline mode), was carried out under various driving conditions. In all cases the original gasoline configuration gave the lowest energy consumption rate. The natural gas energy consumption was in the middle on an overall basis, with the conversion (gasoline mode) figure highest of the three. This highlights the fact that an NGV conversion often slightly degrades the original engine performance when running on gasoline, due to the obstruction of air flow into the intact tract.

The foregoing information suggests that it is misleading to compare energy consumption between natural gas and gasoline on a converted engine. The comparison should be made between the converted engine operating on natural gas, and the original performance of the engine in its dedicated gasoline configuration. A 1988 report²¹ by the U.S. Environmental Protection Agency (EPA) gave consumption comparisons for a variety of bi-fuel light-duty NGV conversions. The results were given in gasoline equivalent miles per gallon (US) figures. An Oldsmobile Delta 88 medium size sedan gave 20.3 mpg(equivalent) (3.81 MJ/km) in original gasoline configuration, 18.9 mpg(equivalent) (4.09 MJ/km) using natural gas, and 17.2 mpg(equivalent) (4.49 MJ/km) using gasoline in the bi-fuel configuration. Natural gas fuel consumption was therefore 7% higher than the original gasoline configuration, but 9% less than when using gasoline in

20 University of Toronto.

21 "Emissions, Fuel Economy and Performance of Light-Duty CNG and Dual-Fuel Vehicles", Robert I. Bruetsch, U.S. Environmental Protection Agency, June 1988.

the bi-fuel configuration. Other vehicles tested showed similar relationships. Generally, the energy consumption for natural gas operation was 7% to 15% higher than the energy consumption corresponding to the EPA certification mpg figure. The tests were conducted according to the EPA composite cycle.

If the engine is optimized for natural gas, an efficiency improvement is possible. The same series of EPA tests included a Ford Ranger pickup truck with a 2.3 L engine, using a 12.8:1 compression ratio. This vehicle recorded 24.4 mpg(equivalent) (3.17 MJ/km) using natural gas on the EPA composite cycle. Its EPA certified gasoline consumption was 24.5 mpg(equivalent) (3.16 MJ/km). The difference is negligible. The latest technology, using lean-burn fuel/air ratios and even higher compression ratios, is likely to offer further engine fuel efficiency improvements.

B. FUTURE TECHNOLOGY

Future light vehicle technology will develop along two parallel lines:

Bi-fuel vehicles: This class of vehicle has an important role to play in the introduction of natural gas as a universal fuel. It will be most valuable in developing countries, where the prospect of renewing large numbers of the existing vehicle fleet in a short space of time is not realistic.

Dedicated vehicles: This class of vehicle represents the theoretical ideal. It will emerge in the technologically advanced countries which are able to support the investment required to put new vehicles and the supporting infrastructure, such as refuelling stations, into place.

ENGINES

Bi-Fuel Engines

The latest generation of bi-fuel natural gas/gasoline conversion kits is designed to interface fully with microprocessor engine management and emissions control systems. The feedback signals from the exhaust oxygen sensor and air mass flow sensor are used to modulate the natural gas feed into the engine to provide optimum power and emissions levels. In addition, the conversion advances the ignition timing when operating in the natural gas mode, and senses the mass of gas flowing to the engine in order to perform the gas to air ratio calculations.

The supply gas stream is positively metered into the engine, in much the same way as in a gasoline fuel injection system. This gives greatly improved accuracy in fuel control and maintenance of the optimum air-fuel ratio. The Gaseous Fuel Injection System (GFI) developed by ORTECH International

is an example of the newest technology. It is applicable to a very wide range of engines, both gasoline and diesel, in power outputs up to approximately 400 bhp. IMPCO and other suppliers market comparable conversion kits. Exhibit V-5 shows a schematic of the latest type of IMPCO conversion kit, indicating the interfaces with the existing vehicle control system.

One logical route for future bi-fuel engines is to optimize the engine for natural gas, and enable gasoline operation at reduced performance for emergency needs only. Toyota has built a pick-up truck with a small bi-fuel four cylinder engine having a 12.5:1 compression ratio. Knock sensors are used to detect knock and retard the ignition timing accordingly when operating on gasoline, but at a considerable sacrifice of power.²²

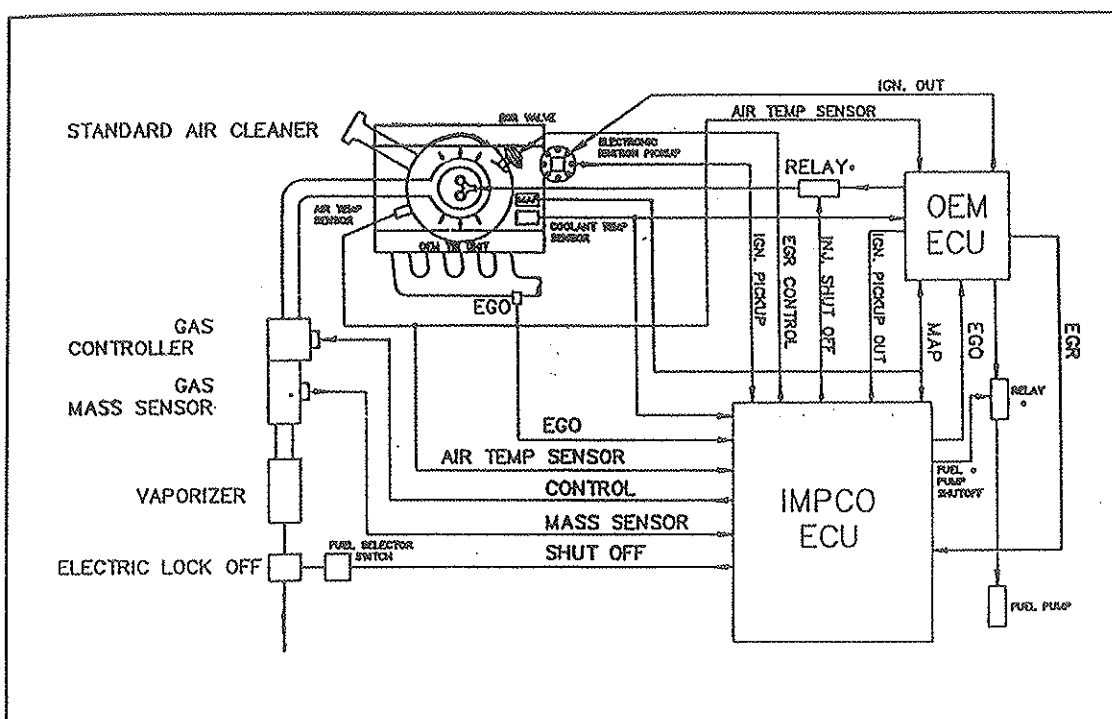

Exhibit V-5. Schematic of IMPCO Electronic Control Natural Gas Conversion Kit

In practice, the technical sophistication of bi-fuel conversions will probably continue to be limited by cost and ease of conversion. Because of this it is unlikely that bi-fuel technology will advance into engine modifications beyond the straightforward "bolt on" type. Future development will centre around

²² M.Nishida et al, "Development of Toyota Electronically Controlled Compressed Natural Gas Vehicles", Proceedings of "Gaseous Fuels for Transportation" Conference, Institute of Gas Technology, Chicago, 1986.

refinement of the interfaces with electronic gasoline control systems, and the natural gas metering valves. Bi-fuel systems will probably continue to be the favourite choice for after-market conversions for the next 2 to 5 years.

Dedicated Engines

A dedicated natural gas engine would not differ significantly in size, weight, construction or materials requirements from a gasoline engine. It could easily provide equal power and torque output. Thermal efficiency, and hence fuel economy, should be superior. The cost of the engine alone should not differ significantly from that of a gasoline engine.

In a dedicated engine the loss of power frequently associated with converted engines may easily be offset by changes which, though difficult and costly to make to an existing engine, are easy to implement at the design and manufacturing stage. For example, increasing the swept volume of an engine from 2.0 litres to 2.2 litres is a comparatively simple matter. An alternative is to alter the valve sizes or valve timing to allow greater air flow. This again is a simple undertaking at the initial design stage, and is frequently done by manufacturers wishing to increase the performance of particular engine models.

The primary directions of current work concerning optimization of light duty gasoline engines for natural gas are as follows:

- Increased Compression Ratio;
- Lean-Burn Combustion;
- Fuel Injection and Air-Fuel Ratio Control;
- Ignition Timing;
- Catalytic Emissions Control;
- Exhaust Oxygen Content Sensors.

Reviewing each of these features in turn:

Increased Compression Ratio

Modern gasoline automobile engines commonly have compression ratios in the 8:1 to 10:1 range. This can be increased as far as 15:1 with natural gas, because of its higher octane rating (130 RON), leading to a theoretical potential fuel efficiency increase up to 12%.²³ Compression ratio increase can also regain some of the power lost in comparison to a similar size gasoline engine. When used in conjunction with lean fuel-air ratios, higher compression ratios can provide efficiency levels superior to contemporary gasoline engines. Increasing the compression ratio increases the mechanical

²³ C.S. Weaver, "Natural Gas Vehicles - A Review of the State of the Art", SAE Paper No. 892133.

loads on the engine, and therefore requires stronger construction. It also demands high precision in machining of the combustion chamber, and tight control of manufacturing tolerances. Because of these practical difficulties production engines will probably use compression ratios around the 12:1 level.

Lean-Burn Combustion

The wider flammability limits of the natural gas/air mixture allow satisfactory engine operation at very lean fuel/air ratios in comparison to gasoline engines. Lambda (air/fuel) ratios up to 1.7 are used in the most advanced natural gas engines. The limiting factor on reliable ignition tends to be the lower flame speed and the design of the engine combustion chamber, and not the mixture flammability. These very lean ratios are currently used in stationary natural gas engines, and yield full-load thermal efficiency equal to diesel with low NO_x emissions. An additional important advantage is reduced exhaust gas temperature, which gives longer exhaust valve life and lower thermal stresses on the turbocharger in turbocharged engines.

In a practical automobile engine, the wide latitude in mixture strength may be used to provide an ultra lean mixture at part load conditions. In effect the engine may be partially controlled by varying the mixture strength instead of throttling the inlet flow. This reduces pumping losses, in addition to the improved thermal efficiency directly resulting from the lean burn. The mixture may be easily enriched to stoichiometric for full power situations, but since the average light-duty automotive engine rarely operates at full power the high efficiency and low emissions mode would generally prevail.

Operation on an over lean mixture causes misfiring and engine knock. Gasoline engines using lean-burn techniques may use exhaust oxygen level feedback and cylinder knock sensors to control fuel injector output and instantaneous spark timing in order to avoid these conditions. These techniques are equally applicable to a natural gas engine. The lean burn engine may also employ a highly sophisticated combustion chamber design. Good results have been obtained with a prechamber system in which a rich mixture is pre-ignited in a small separate combustion chamber. The resulting hot burning gases are then released down a narrow connecting passage into the main lean-mix gas/air charge.

Fuel Injection and Air-Fuel Ratio Control

Optimization of engine performance, particularly with respect to minimizing exhaust emissions levels, is very much influenced by the precision and accuracy of the fuel metering process. Dedicated natural gas engines will use gaseous fuel injection systems which positively meter a pressurized stream of gas into the engine inlet air through an electronically controlled valve. These

are the same systems which will be used on bi-fuel conversions. The ORTECH/Stewart & Stevenson system is comparable to a throttle body gasoline injection system. The gas for all cylinders is introduced through a single port in the inlet manifold. The gas stream is metered by a valve block containing seven or eight individual valves, depending upon the desired system flow capacity. These valves are controlled by the central microprocessor system. In operation, the system opens varying numbers of valves, sometimes at different frequencies, to achieve extremely accurate control of the gas flow rate across the full range of engine operating speeds and loads. The temperature of the gas passing into the intake manifold is monitored in order that the system can make corrections for varying gas density. Exhibit V-6 shows a schematic of the major components.

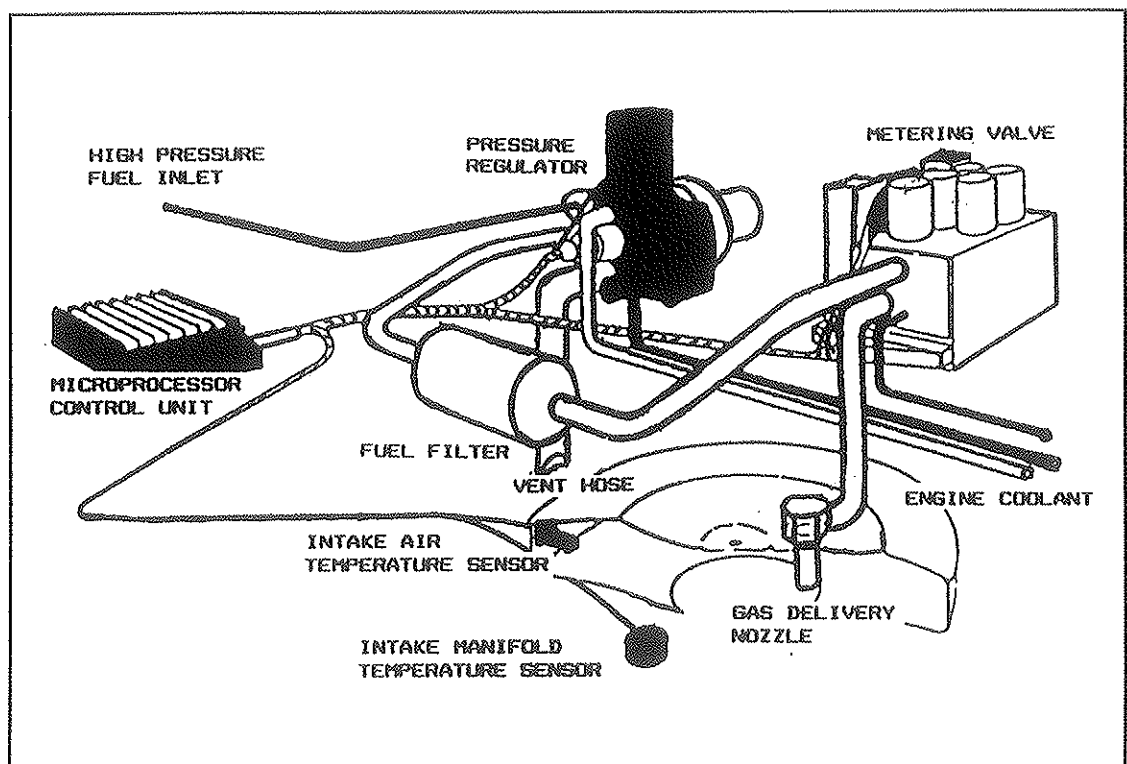

Exhibit V-6. Schematic of the ORTECH "GFI" Gas Injection System

Tecogen Corporation has developed a natural gas fuel metering system which has been successfully applied to large gasoline engines intended for use in buses and medium weight trucks. Dedicated natural gas vehicles with Tecogen equipment have been in service for over 5 years, and the system is to be used on many of the fleets currently going into service in the U.S.A.

Ignition Timing

The flame propagation speed of a natural gas/air mixture is lower than that of a gasoline/air mixture. Combustion duration is therefore likely to be

longer, and engine efficiency will be impaired if spark timing is not advanced to compensate. Natural gas also requires a higher energy spark to ignite reliably. If lean-burn engine control strategy is employed, the demands on the ignition system are magnified further, since the required spark energy for ignition increases, and the flame propagation speed decreases. Combustion duration and temperature peaks are important to emissions as well as engine efficiency, particularly regarding NO_x control. An optimized natural gas engine therefore needs a sophisticated ignition system capable of providing a powerful spark. In theory, the production of such a system is not a problem. However, in practise the need to interface with existing control systems in bi-fuel applications, and the desirability of using standard components for reasons of economy, has tended to inhibit the development of suitable technology until a truly viable market appears.

Catalytic Emissions Control

The introduction of electronic feedback controls and fuel injection systems into the natural gas vehicle market has opened the way for the use of three-way catalytic converters to control NO_x, CO and HC output. Research into catalyst formulations, matrix loadings, converter size and other topics is well under way. Emissions control is achieved by the same method of adjusting the fuel injection rate according to the free oxygen detected in the exhaust gas when using three-way catalysts with stoichiometric combustion engines. Oxidation catalysts are used with lean burn systems.

Catalytic converters for stoichiometric natural gas engines are typically 50% larger, or have 50% greater precious metal loading, than converters for gasoline engines. NO_x control is receiving much attention, since NO_x reduction is particularly difficult when operating at lean air-fuel ratios. Control of unburned methane is also a major topic of investigation. There is considerable difference of opinion regarding the importance of methane control. Palladium is showing promise as a suitable catalyst for situations where emissions regulations include methane in the hydrocarbon emissions count.

Exhaust Oxygen Content Sensors

The development of exhaust oxygen content sensors compatible with the characteristics of natural gas exhaust is essential for the achievement of lowest possible emissions levels. Particular features under investigation include accuracy and dynamic response, and the possibility of directly monitoring individual NO_x, CO and HC content levels.

2. VEHICLES

Optimization of vehicle technology for gaseous fuels is largely concerned with storing sufficient fuel on board to give a reasonable operating range. The natural gas power unit will not differ noticeably in size, shape or weight from its gasoline equivalent, neither will there be any need for change in the vehicle transmission exterior configuration. Auxiliary requirements such as cooling, lubrication, starting and alternator systems will not have to be changed.

There are two ways in which to carry more fuel on the vehicle, increase the space available or increase the stored energy density. A custom designed vehicle could definitely provide more space by reconfiguring the overall layout to provide suitable locations for storage cylinders. However, a 50 L natural gas cylinder holds the equivalent of approximately 15 L of gasoline, and therefore around 3.3 times as much space must be found to retain equal range. The problem of finding adequate fuel storage space tends to intensify as the vehicle size decreases, although at present some of the more imaginative answers are found on the biggest vehicles. An example is the mounting of large capacity cylinders on bus roofs. Possible avenues for smaller vehicles could include similar roof mounting, or use of storage cylinders as a structural member. At present there is little interest in the field of vehicle design as an integrated whole, and future natural gas vehicles will probably continue to share basic body and chassis with gasoline vehicles.

Increasing the density of gas storage by raising the pressure is perfectly possible from a simple engineering point of view. Equipment to use pressures of 30 MPa and above is readily available. However, for a number of reasons increasing gas pressure tends to quickly lead to a situation of cost outweighing benefit.

The use of liquefied natural gas would require approximately 1.5 times as much storage volume as gasoline. Liquefied gas storage is also perfectly feasible from a technical point of view. Again the objections are economic, mainly due to the increased complication of the equipment. In addition, the liquefied gas will slowly evaporate with consequent waste and increased emissions from vehicles used infrequently.

Adsorptive storage is not yet practical for vehicle use. A number of disadvantages have to be overcome including progressive loss of capacity and strength in the adsorptive materials. This technique is very attractive in theory, and could make the storage of fuel much easier if perfected.

Most light vehicles, at least for the next 10 years, will continue to use gas cylinders pressurized to 20 MPa to store fuel. There will be increasing use of composite construction metal/plastic or all plastic cylinders, which will

minimize any weight penalty. However natural gas light vehicles will probably continue to have shorter range than gasoline or diesel vehicles, unless some sacrifice of passenger accommodation or luggage space is made.

C. SUMMARY

Natural gas as a fuel for light vehicles has a long history, and is currently used by about 700,000 cars, vans and trucks, in countries as diverse as Italy, New Zealand, Argentina and Canada. It is evident that this fuel can provide acceptable standards of vehicle performance and economy under a wide range of climatic and operating conditions. The technology for the conversion of gasoline engines is proven and reliable. However, most bi-fuel conversions of gasoline engines to date have not been optimized for either fuel, resulting in loss of power and reduction in engine efficiency. Power typically declined by 10%, and fuel efficiency reductions in the 3% to 15% range have been noted. The advent of conversions using the latest electronic control techniques, able to interface effectively with existing gasoline engine management and emissions control systems, has reduced these problems considerably.

Prominent scientific and engineering research institutions all over the world are exploring and perfecting the natural gas engine. A dedicated monofuel natural gas engine using the latest technological advances can provide power and performance equal to a similar gasoline unit, with superior fuel efficiency. Advanced natural gas engines are available, but have not yet undergone extensive testing in "real world" operating conditions.

Lightweight composite construction gas storage cylinders are being used to reduce the weight penalty involved in storing useful quantities of gas on a vehicle. Despite this work, natural gas vehicles may remain inferior in range capabilities. The fundamental way to attack the problem of fuel storage volume is to increase the cylinder pressure, and studies have shown that a situation of "diminishing returns" appears at pressures much above 20 MPa. Cylinder weight starts to rise because of the need for stronger construction. The work required to compress the gas also rises, so increasing the effective cost of the gas, and reducing its overall energy saving advantages. It seems likely that high pressure compression to 20 MPa will remain the preferred method of storage in the foreseeable future although U.S. vehicle manufacturers are promoting 24MPa. The technique of adsorption is exhibiting many drawbacks such as unacceptable fuel retention ratios, and in any case still requires compression pressures in the 4 MPa to 8 MPa range for optimum results. Cryogenic liquefaction is too complicated and costly for private vehicle use, although it shows promise for heavy duty vehicle applications.

No manufacturer has yet marketed a complete vehicle designed from the outset for natural gas fuel alone. Some offer factory installed conversion kits. Ford, General Motors, Chrysler and Toyota have developed light trucks and vans with engines optimized for natural gas. The U.S. manufacturers are gearing up for large scale production, and several thousand of these vehicles will be supplied in the period from 1992 to 1994. However, all such vehicles remain in essence adaptations of designs originally intended for liquid fuels. A truly optimized natural gas vehicle would require a body or chassis configured to give maximum storage volume for minimal weight penalty, as well as an optimized engine. There is no doubt that an optimized natural gas car could provide on-road performance and fuel efficiency to match modern gasoline cars, and could be built without undue difficulty. However, there is no commercial incentive to develop such vehicles until a reliable fuel supply network is in place, and there is some hope of a viable market for them.

Natural gas fuelling stations are still uncommon in most countries, and it will be a long time before the fuel is as readily available as gasoline. Even the act of fuelling the vehicle cannot be undertaken without special training in many parts of the world. Individual slow-fill "home-fuelling" compressors could be one way to establish a fuel supply system without the major capital investments involved in constructing commercial compressor stations. These devices offer unique convenience in refuelling to the private motorist, which cannot be duplicated by gasoline. They are also well suited to many types of small fleet operation. The use of mobile storage trailers is also well developed, and offers another method by which the gas supply system may be expanded.

The appeal of natural gas is still largely confined to vehicle users whose prime concern is saving fuel costs, and who are able to cope with the restrictions on overall mobility due to short range and lack of widespread fuel availability. Prominent examples are taxi operators and local delivery fleets. The path ahead will include major advances in standards of performance, reliability, efficiency and emissions control. The marketing of production natural gas vehicles by major manufacturers will considerably increase consumer confidence in this new fuel. Increased market share will still depend heavily upon the synergy between vehicle initial price, comparative fuel costs, and fuel availability.

VI HEAVY DUTY VEHICLE UTILIZATION

A. CURRENT VEHICLES AND TECHNOLOGY

Market Penetration

Exhibit VI-1 gives a breakdown of the current known world population of heavy duty natural gas vehicles. It will be apparent that the number of heavy vehicles in operation (approximately 600 in all) is only a small fraction of the light vehicle total. It is understood that Russia and China have some heavy natural gas vehicles in service, but the numbers involved are unknown. The U.S.A. has around 20 vehicles in service, and there are plans in place to substantially increase this number in the next few years.

Exhibit VI-1. International Distribution of Heavy Duty Natural Gas Vehicles²⁴

Country	Vehicles
Italy	20
Argentina	10
New Zealand	100
Canada	25
Brazil	300
Australia	112
Bangladesh	13
Thailand	11
Japan	1
Sweden	5

About half of the heavy duty vehicles are buses, the rest being trucks of various configurations, ranging up to large tractor-trailer units. Many of the vehicles are engaged in trial programs, and several are owned by governmental organizations. Australia and New Zealand have advanced furthest in true commercialization of natural gas heavy vehicles. The city transit systems in Sydney, Brisbane, Adelaide, Melbourne, Geelong and Perth (Australia), and Auckland and Palmerston (New Zealand) have all been operating natural gas buses for periods up to 10 years. Many use

²⁴ International Association for Natural Gas Vehicles (IANGV), Newsletter No. 20, September 1991.

converted Mercedes V-6 diesel engines. Passenger transit buses have become a primary target for all types of alternative fuels. A leading factor favouring NGV use is the need for few fuelling points (frequently only one will suffice in small to medium size communities), and a duty schedule allowing regular time periods for refuelling.

Almost every country running heavy-duty natural gas vehicles began with transit buses, and the majority of future plans revolve around the same class of vehicle. In the U.S.A., Detroit Diesel Corporation and Cummins Engine Company have both identified the transit bus industry as the most viable near term market for heavy duty NGVs. Approximately 15 natural gas buses are operating in Los Angeles and the surrounding area. In Houston, Texas, a prototype dual fuel bus using liquefied natural gas is under test. The city plans to put over 300 similar vehicles into service by 1995. California has plans for the early introduction of over 100 natural gas heavy vehicles, including additional transit buses, trucks and school buses.

In Canada, the city of Hamilton operates 25 natural gas buses. Toronto and Mississauga have been introducing NGV buses into their fleets during the 1990-1991 period, and have plans to put 50 units on the road. Vancouver has 5 natural gas buses on the road and is planning more. The latest buses at Toronto and Mississauga are manufactured by Ontario Bus Industries, and use Cummins L10 spark ignition engines. The fuel storage cylinders are mounted on the roof to provide maximum fuel capacity. The Hamilton buses use Italian IVECO 9.5 L and Cummins L10 engines, with the storage cylinders in a more conventional position under the bus floor.

In Italy, IVECO natural gas engine are scheduled to go into service in 5 buses in the city of Ravenna. These buses will have two 450 L capacity gas storage cylinders mounted on the roof. The city of Florence is also undertaking a program to convert transit buses to natural gas operation.

In early 1992 Volvo delivered the first two factory built dedicated natural gas buses in Europe to the city of Goteborg, Sweden. These will be followed by 18 more during the next year.

Holland has been operating experimental natural gas buses since 1989. All use DAF diesel engines converted to natural gas by TNO. The Central Netherlands Transit Company put one bus into service in June 1989, and plans to convert 10 more. A further 7 buses are in service as part of a joint project between the cities of Groningen, Rotterdam and The Hague. By late 1991 the buses had completed over 380,000 km in passenger carrying service. Several other international manufacturers including Daimler Benz, Leyland, and Ikarus of Hungary have engines and/or complete natural gas vehicles in advanced stages of development, and are ready to supply the potential bus market as it develops around the world.

A viable long-term market for heavy duty natural gas vehicles has not emerged as yet. It is approaching reality in the bus field, and will be assisted by recent U.S. legislation mandating the use of clean fuel vehicles in fleets operating in areas having excessive air pollution. Light duty natural gas vehicles have found a market primarily because of the saving in fuel costs when compared to gasoline. In many countries, for example Italy, the price of diesel is considerably below that of gasoline, and therefore the margin of fuel cost savings between diesel and natural gas is much smaller than the margin between gasoline and natural gas. In addition to this, natural gas heavy vehicles must compete against the very high standards of reliability and longevity attained by diesel trucks and buses. The expected life of a heavy diesel engine is much longer than that of a gasoline engine, and prospective natural gas purchasers may be reluctant to buy until they have seen a consistent technology proven over 4 or 5 years of use. They would also much prefer to see the technology designed, fitted and guaranteed by the original engine manufacturer, and not supplied as an aftermarket conversion kit.

The scarcity of refuelling stations also rules out the use of natural gas for many fleets, particularly those operating long distance delivery trucks which have to be prepared to travel anywhere. Since it will take several years for a widespread fuelling network to develop, the immediate natural gas truck marketing prospects are confined to local delivery fleets, or long distance vehicles running on defined routes. Municipal service and garbage collection vehicles have been identified as a good potential market by the American Gas Association. At present plans are well advanced for the introduction of five heavy trucks in the Los Angeles area, and ten medium trucks in New York. In Australia and New Zealand trucks using a variety of converted diesel engines, including Cummins, Mitsubishi and Mercedes, are operating in normal commercial fleets.

Technology Used

Development of natural gas engines suitable for use in buses and heavy trucks did not really get under way until about 10 years ago. However, there is a large fund of applicable experience available from the small engine field, and also from the long established use of natural gas in stationary engines. As a result progress has been fairly rapid, and current technology sets high standards of performance, fuel economy and emissions control. Development has focussed almost exclusively on the conversion of existing diesel engine designs, just as the smaller engines are generally conversions of gasoline units. However, the conversion of a diesel engine is more complicated, because natural gas cannot be made to ignite by using compression heat alone unless the compression ratio is increased substantially. All practical conversions to date have employed one of two methods to achieve ignition. One is diesel fuel injected into the gas-air mixture, the other is an electric ignition system and spark plugs.

The first type of engine is termed "dual-fuel" because it requires the simultaneous use of two fuels, natural gas and diesel, to operate. It is thus distinguished from a "bi-fuel" engine, which can operate on two fuels, but only uses one of them at a time. The dual-fuel engine is also known as a "pilot injection" engine, because the diesel fuel acts as a starter or pilot for the combustion of the main natural gas charge.

The spark ignition type of engine is referred to as "dedicated" or "monofuel", because it runs on natural gas alone.

Dual-Fuel Engines

The dual fuel engine retains the original diesel injection system. The governor system is adjusted so that maximum diesel delivery is restricted to the engine idling level or a little above. Natural gas is fed into the inlet manifold of the engine through an air-fuel mixer, or gaseous fuel injection unit, as used for gasoline engine conversions. The introduction of gas in this manner is often referred to as "fumigation" in connection with diesel engine conversions. The engine usually starts and idles on diesel fuel alone. Increased speed and power are obtained by opening the supply of gas to the mixer unit. The engine therefore takes in a combustible mixture of gas and air instead of air alone, and this mixture is ignited in the cylinder by the small pilot charge of diesel fuel. In a simple conversion the amount of diesel injected remains constant, and progressive increases in speed and power output are obtained by increasing the gas flow rate into the inlet manifold. The proportion of the two fuels varies according to engine load and speed, from 100% diesel at idle, up to approximately 5% diesel and 95% natural gas at full power output. The overall ratio of fuels consumed depends upon the engine duty cycle.

Engine control may be achieved by controlling the supply of natural gas to the air-fuel mixer. Although the system of operation is analogous to an Otto cycle engine this type of conversion can work without throttling of the intake charge. The wide ignition range of a natural gas/air mixture, and the high energy source of ignition provided by the diesel pilot, combine to allow combustion over a wide range of engine loads and speeds.

More sophisticated dual fuel conversions make use of electronic control technologies and intake charge throttling to dynamically adjust the gas-air-diesel ratios during engine operation, thereby achieving better combustion and more effective use of natural gas. For example, British Columbia Research Corporation, in conjunction with Caterpillar Inc. has built dual fuel engines using advanced control systems.²⁵ A Caterpillar 3208 engine, a

²⁵ Gettel L.E., et al, "Microprocessor Dual-Fuel Diesel Engine Control System", SAE Paper No.861577.

popular medium truck diesel power unit developing around 250 bhp, was converted to dual fuel. It showed nearly identical torque characteristics to the original diesel configuration, with similar peak cylinder pressures, and comparable thermal efficiency under heavy load. The proportion of natural gas consumed ranged between 76% and 85% in a series of full load tests at varying speeds. Detroit Diesel and Stewart & Stevenson have developed a dual fuel version of the DDC two stroke engine which is used in buses in some current U.S. test programs.

Fumigation with pilot injection is the simplest way to modify a diesel engine to use natural gas as fuel. The equipment required is virtually the same as that needed for a gasoline engine conversion, and the necessary modifications to the diesel injection system are easy to make. Hence the conversion can be accomplished at reasonable cost using standard equipment. Conversion back to diesel operation is correspondingly straightforward, and the natural gas equipment can be left in place if required. One reason for using fumigation with pilot injection is therefore to replace diesel fuel with lower cost natural gas when a gas supply is available, without losing the ability to revert back to diesel fuelling if necessary.

Disadvantages of dual fuel engines include the need to maintain two separate fuel systems on the vehicle. There also tends to be some compromise over ideal natural gas combustion because of the need to maintain a high compression ratio. The diesel combustion may also produce some particulate emissions.

If the performance of a dual fuel conversion is enhanced by using electronic controls, gaseous injection systems, and intake charge throttling the cost of conversion rises accordingly. The benefits obtained include higher proportions of natural gas used, and lower exhaust emissions levels. Whether these outweigh the extra costs depends upon the local gas to diesel price comparisons, and the need to comply with emissions regulations.

Dedicated Monofuel Engines

Conversion of a diesel engine to dedicated natural gas operation involves more fundamental modifications than a conversion to dual fuelling. The engine has to be converted to Otto cycle operation, using intake charge throttling and spark ignition, so that a dedicated heavy duty engine shares much in common with an optimized gasoline conversion. The natural gas fuel is introduced into the inlet manifold using a mixer or injection system, exactly as for a dual fuel conversion. The diesel injection system is removed completely. Because there is no requirement for compression ignition the compression ratio is lowered from the 15:1 to 19:1 range common in diesel engines to around 13:1, in order to obviate knocking on natural gas fuel.

Because of the potentially lean fuel-air ratios, low flame propagation speed, and high compression ratio, the ignition system must be capable of providing a very high energy spark. All current designs use an individual, electronically triggered, coil for each spark plug. The piston rings and valve guide seals may require modification in order to prevent lubrication oil being drawn into the combustion chamber due to the vacuum created by throttling the intake charge. For optimum efficiency and emissions reduction, the shape of the combustion chamber is critical, and a number of specialized configurations; for example, the Ricardo "Nebula", have been developed in order to give ideal air-fuel mixing and combustion characteristics. Changing the shape of the combustion chamber is a major task on an existing engine, and usually involves manufacturing and fitting entirely new cylinder heads.

Current heavy duty dedicated engine development is pursuing two distinct courses, lean burn combustion, and stoichiometric combustion.

The main features of lean burn combustion have been described in connection with optimized light duty engines. The advantages of lean burn engines include intrinsically low NO_x and CO emissions; high thermal efficiency due to low pumping losses and ability to use high compression ratios; and low exhaust gas temperature, which can benefit valve and turbocharger life. The disadvantages are lower maximum power potential, and the tendency to higher HC emissions which is characteristic of non stoichiometric combustion of hydrocarbon fuels. The HC emissions may be dealt with by using an oxidizing catalytic converter.

Stoichiometric combustion is similar to the principle employed in most modern gasoline automobiles. The air-fuel ratio is maintained around the ideal stoichiometric point by modulating the fuel feed according to signals from an exhaust gas oxygen content sensor. The principle advantage of stoichiometric combustion is higher potential power output, and minimization of engine-out HC emissions. Final emissions reductions are made with a three-way catalytic converter. A significant disadvantage when converting a diesel engine is a rise in combustion and exhaust gas temperature of up to 200⁰C. This tends to increase NO_x formation. It can also require fairly extensive modifications to valves and pistons if durability is not to be impaired. Exhaust gas recirculation is sometimes used to lower the peak combustion temperature.

Exhibit VI-2 is a schematic of a stoichiometric combustion Caterpillar 3306 10 L engine which was developed by BC Research and IMPCO.²⁶ The basic engine was a standard Caterpillar spark ignited gas engine intended for stationary industrial use.

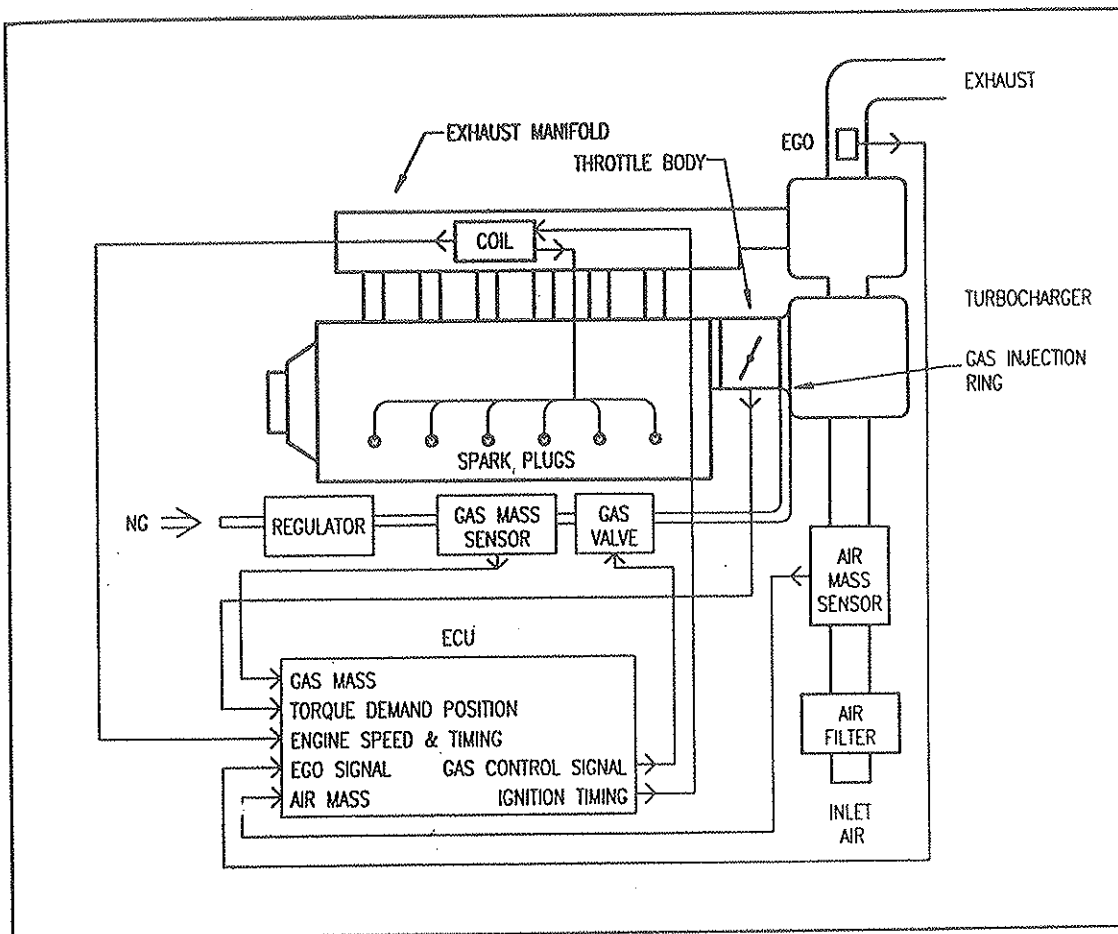

Exhibit VI-2. Schematic of Caterpillar Stoichiometric Combustion Engine

Most major international diesel engine manufacturers are engaged in development of dedicated natural gas engines, frequently in partnership with independent research organizations. The Co-Nordic Natural Gas Bus Project is an example. A consortium of Scandinavian Public Transit Companies is sponsoring development of Scania and Volvo engines at Ricardo in the U.K. and Southwest Research in the U.S.A. The Dutch TNO organization is co-operating with DAF. Other prominent joint efforts include Caterpillar and BC Research, Cummins and ORTECH, and Detroit Diesel and Stewart and Stevenson. Many manufacturers are able to draw

²⁶ "A Low Emissions Spark Ignition Natural Gas 3306 Caterpillar Engine", Gettel L.E., Perry G.C., Smith D. Paper presented to the 1991 Windsor Workshop on Alternative Fuels.

directly on stationary engine experience. For example, Caterpillar has marketed stationary natural gas versions of its 3306 and 3406 engines for many years. The diesel versions of these engines are widely used in trucks and many types of mobile and industrial equipment.

There is at present no clear indication of which technology, lean burn or stoichiometric, will be most used in the future. Stoichiometric engines depend upon advanced control techniques, particularly regarding the need for precise monitoring of exhaust oxygen content, to give best performance. Most current engines use lean burn, which can give good driveability together with the ability to meet any currently proposed emissions standards. Stoichiometric combustion may become more popular as the capabilities of microprocessor control systems improve, and the costs fall. Many companies are experimenting with both technologies.

Performance and Driveability

A typical truck or bus diesel engine is normally marketed with a range of different power and torque outputs. Current natural gas conversions are usually designed to give power outputs in the low to middle end of the diesel range. The potential power output in comparison to the base diesel engine is dependent upon the conversion technology chosen. As for light duty engines, ultimate natural gas power output capabilities cannot be achieved without extensive re-design. The need to introduce natural gas into the engine through the induction manifold results in a displacement of approximately 10% of the oxygen available for combustion, as is the case for a gasoline conversion. All other things being equal this would be expected to cause a 10% loss of peak power. However, the actual power loss depends upon many factors, including the original design capacity of the inlet air ducts, the valve timing, and boost characteristics if the engine is turbocharged.

Natural gas fuelling can allow the engine designer to provide more torque output over the speed range, because the maximum fuelling rate is not smoke limited. However, the extent to which this advantage can be exploited also depends upon the output of other emissions, and the rate of cylinder pressure rise. These factors tend to be very specific to the type of engine involved. In a practical conversion, the designer also has to consider heat dissipation rates from critical components such as pistons and valves before selecting a power output rating.

Although the theoretical considerations and comparisons are complicated, in general terms it is possible to configure a natural gas engine to provide power and torque curves equal to a comparable diesel unit, and several conversions have achieved this design target. This translates into similar on-road

performance. Experience in commercial operating fleets and field trials shows that natural gas vehicle performance and driveability characteristics can be equal to diesel vehicles.

The Southern California Rapid Transit District (SCRTD) presently is conducting an extensive trial of alternative fuelled buses. The program includes 10 natural gas buses, fitted with Cummins L10 monofuel spark ignition engines. SCRTD issues regular reports on the progress of the trials.²⁷ The natural gas buses have been criticized for poor acceleration in comparison to similar diesel buses. Two reasons are given for this, the natural gas engines are rated at 240 bhp, versus the 270 bhp of the diesel engines, and the natural gas buses are approximately 1,200 kg heavier than the diesel buses due to the weight of the fuel storage cylinders. A 270 bhp version of the Cummins natural gas engine is expected to be available in 1993. In the meantime SCRTD has been testing different types of automatic transmission to see if better matching of engine and transmission characteristics can improve acceleration. As a result buses with the L10 natural gas engine are being re-equipped with a different torque converter and other transmission modifications, which have given acceleration equal to the fleet standard requirement on trials.

This experience highlights three points relevant to natural gas engine performance. The first is that it is important to ensure that any comparisons are made against a diesel engine of similar specification. For instance, the Cummins L10 diesel engine is supplied in a number of power ratings in the 200 bhp to 300 bhp range, whereas the natural gas version is at present available only in a 240 bhp rating. The rated power of the natural gas engine may theoretically be adjusted over a range similar to the diesel by modifications to the control system. However, in practise it takes considerable time and testing to set up an engine (natural gas or diesel) for an alternative power output, whilst maintaining optimum efficiency and exhaust emissions levels.

The second point is that it may be necessary to specify slightly higher power natural gas engines in order to compensate for increased vehicle weight due to the gas storage cylinders. This consideration is highly dependent upon type of fleet and vehicle duty cycle. Acceleration is critical in bus fleets because of the "stop-start" nature of bus routes. The third point is the necessity of designing the vehicle power train as a whole when optimizing performance. As the number of natural gas engines in service grows more transmission and power train matching work will be carried out, which will be reflected in further improvements to the performance and driveability of natural gas buses and trucks.

²⁷ Ibid page 5.

The reactions of drivers during natural gas bus tests are generally very positive. They are often enthusiastic about the smoother running, lower noise levels and lack of fumes and smell in comparison with diesel buses. Fleets as far apart as Los Angeles, Auckland and Trondheim report favorable reactions. Drivers frequently show a strong preference for the natural gas powered vehicles after an initial adjustment period.

Durability and Reliability

A natural gas engine converted from a diesel engine should provide equal or better reliability from the crankshaft and bearings, since the peak cylinder pressures tend to be lower. A lean-burn conversion will not increase the thermal loading on engine components, in particular the valves and pistons, and so may be expected to have a minimal effect on durability, subject to the remarks about valve wear in the paragraph below.

Combustion temperature in a stoichiometric natural gas engine is up to 200°C higher than a diesel engine, unless temperature control techniques, such as EGR, are used. This means that the pistons, cylinder heads, valves and exhaust manifold must be modified to withstand the temperature increase if reliability is not to be seriously impaired.

Using natural gas in an engine designed for diesel can result in increases in valve seat wear because of the absence of combustion soot, which provides lubrication for the valve seats. The solution is to use harder valve and valve seat materials. Valve seat inserts made of sintered alloy steel with a high temperature solid lubricant have been used instead of the induction-hardened cast iron seats normally used.²⁸ Work is also in progress regarding use of ceramics in the valve train.²⁹

Electric spark ignition systems tend to be less reliable than diesel injection systems, and require regular replacement of spark plugs. Some fleets report problems with waterproofing of ignition components. The high energy systems employed are vulnerable to external leakage of ignition current if insulation is not of a high standard. Changing spark plugs is an additional maintenance requirement in comparison to diesel, but can be integrated with other routine servicing in order to minimize the impact on vehicle availability.

²⁸ Motta R.C., et al., "The Design and Production of Chrysler Canada's 1987 Propane-Fuelled Vehicles", Conference "Gaseous Fuels for Transportation", Vancouver, Canada, August 7-10, 1986.

²⁹ Schreiner M., "Ceramic Valve Train Materials Investigation for Advanced Industrial Natural Gas Engine", SAE Paper No.870418.

The gas pressure regulator and the engine control system incorporate a number of sensitive components, including feedback sensors, which are not fully proven in heavy-duty vehicle applications. These may deteriorate over time, causing some reduction in overall reliability. However, it is probable that any deficiencies uncovered would be rapidly corrected if large numbers of natural gas vehicles began entering service.

Testing has shown an increase in the useful life of engine oil, in some cases allowing the oil change interval to be doubled. Advantages include no engine oil dilution, or cylinder wall washdown, and no oil contamination with carbon particulates or sulphur derived acids. Special lubrication oils for natural gas engines require less additives than diesel lubrication oils. Since oil life is affected by the deterioration rate of the additive pack, a natural gas engine may sometimes be run for longer before an oil change becomes necessary.

Experience with spark ignition conversions shows that, with careful planning and the use of appropriate engine components, there should not be any significant increase in maintenance requirements and costs, or any decrease in engine life. However, because the maintenance requirements for a natural gas engine and fuel storage system are significantly different to those for a diesel engine, there is a need for maintenance staff to be thoroughly trained in all new procedures if fleet reliability is not to be compromised.

Fuel Consumption

The thermal efficiency of a diesel cycle engine is better than that of an Otto cycle engine. Diesel engines operate at high compression ratios, and incur minimal air pumping losses because they are not throttled. In addition the energy density of diesel fuel is higher than that of gasoline. A dedicated natural gas engine may be expected to give a theoretical efficiency somewhat higher than gasoline but lower than diesel, because it operates at an intermediate compression ratio and can dispense with throttling for at least part of its operating cycle. Practical fleet tests report fuel consumption figures in a wide variety of units, which makes comparison difficult. One factor frequently overlooked when using volumetric or mass units is the variation in natural gas energy content. The most valid units for comparison are energy consumption or thermal efficiency.

In New Zealand, fuel consumption results from a natural gas bus operated by Howick and Eastern during 1988³⁰ compared very well with similar diesel units on an energy basis. Average figures over six months of use were:

³⁰ Raine, R.R. et al, "Conversion of Diesel Engines to CNG Spark-Ignition Operation", Ministry of Energy Report No. RD8802, New Zealand, 1988.

Natural Gas Bus:	10.89 MJ/km
Diesel Bus 1:	10.92 MJ/km
Diesel Bus 2:	10.70 MJ/km

In Norway, Trondheim Transit operated a lean-burn Scania 11 L natural gas bus.³¹ Over a 12 month period, 5% to 8% more energy was used compared to the diesel Scania buses that operated on the same route. The conversion was made by Norwegian Marintek, which is preparing to produce this type of natural gas engine commercially.

IVECO tested the relative efficiencies of its 9.5 L engine in natural gas and diesel versions.³² Peak natural gas efficiency reached 36.5%, which was somewhat less than the diesel engine. Tests simulating a typical urban bus duty cycle showed 34% efficiency for diesel, and 25% for natural gas. The natural gas engine efficiency at part load was considerably below the diesel value owing to intake charge throttling losses.

Southwest Research Institute is undertaking natural gas research for several prominent manufacturers. In a 1991 report³³, it published the chart reproduced as Exhibit VI-3, which shows thermal efficiencies achieved by natural gas conversions of engines from Hercules, Cummins, Caterpillar, and Volvo. Typical ranges for modern diesel and gasoline engines are included for comparison. No natural gas engine equals diesel efficiency, but all the lean burn conversions fall within the 35% to 37% range. The single stoichiometric engine included gave approximately 28% efficiency.

Detroit Diesel reported similar results from tests of five different versions of its 6V-92TA two-stroke bus engine.³⁴ A dual fuel version gave almost constant 34% thermal efficiency at full load over the entire operating speed range. A spark ignition version showed values in the 24% to 30% range. These values may be compared to 38% to 40% for the standard diesel engine.

31 Paper presented by Trondheim Transit to Natural Gas Conference in Oslo, Norway, December 1990.

32 "IVECO Low Emission CNG Engine for Transit Bus", Signer M, Cornetti G, Iveco Motorenforschung AG. Paper presented to the 1991 Windsor Workshop on Alternative Fuels.

33 "Natural Gas Engine Combustion and Emissions", Vineyard S, Southwest Research Institute. Paper presented to the 1991 Windsor Workshop on Alternative Fuels.

34 "Detroit Diesel Natural Gas Engine Development Status", Windsor R, Detroit Diesel Corporation. Paper presented at the 1991 Windsor Workshop on Alternative Fuels.

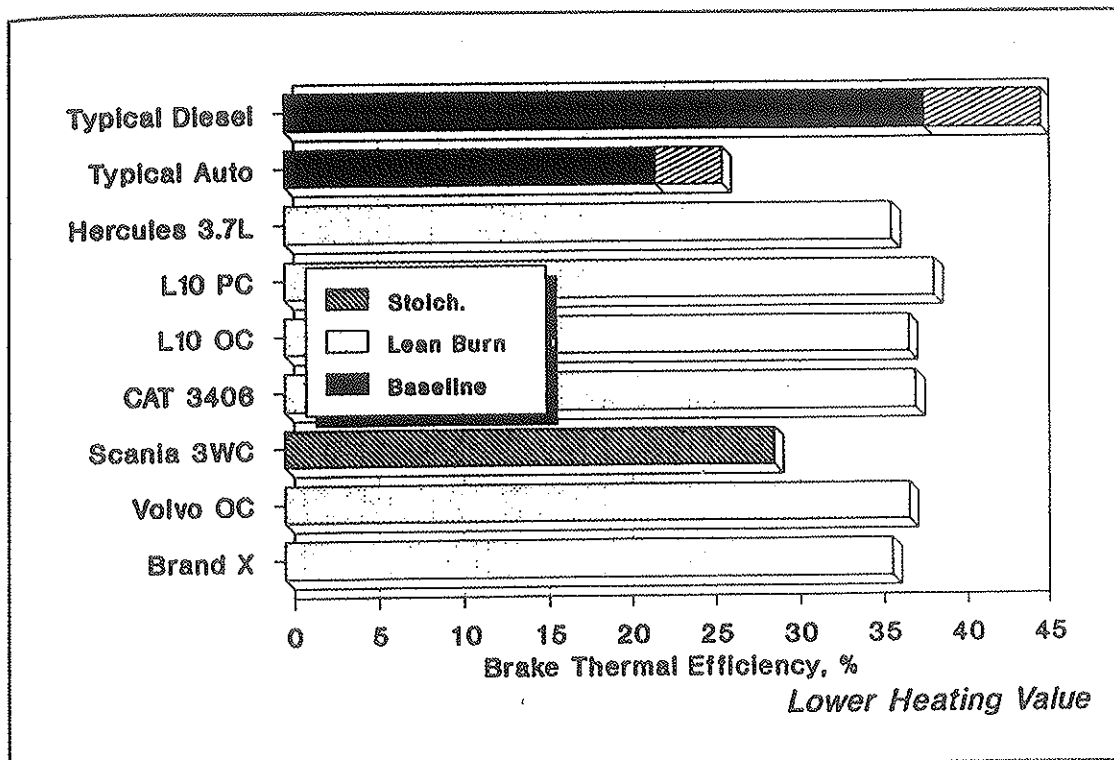

Exhibit VI-3. Heavy-Duty Natural Gas Engine Thermal Efficiencies

Results from buses in operation generally indicate between 5% to 10% loss in fuel efficiency. Future development is expected to reduce and eventually eliminate this gap between diesel and natural gas engine thermal efficiency.

B. FUTURE TECHNOLOGY

Engines

Existing heavy duty natural gas engines are almost all based on current diesel engines. This tends to impose limitations on basic features of design such as maximum rotational speed, combustion chamber shape, piston cooling, and intake system air flow characteristics. Some Tecogen conversions have been fitted to heavy duty six and eight cylinder gasoline engines, of a type common in the U.S.A., but little used in Europe and other parts of the world. Generally the policy of engine manufacturers is to wait until heavy duty natural gas vehicles show signs of becoming a sizeable market, before they attempt to produce engines designed specifically for natural gas.

Future dedicated natural gas engines for heavy vehicles will share many fundamental features in common with light duty engines, since the general trend is toward Otto cycle operation using high compression ratios. The Tecogen conversions are an example of this, and to some extent point to a

possible return to the time when trucks and buses as well as cars were powered by spark ignition engines of basically similar configurations. The ideal heavy duty natural gas vehicle engine may prove to be lighter in construction and run at somewhat higher speed than current diesel engines.

Some specific current areas of research include combustion chamber profile, electronic engine management systems, compression ignition, and gas injection systems.

A natural gas flame propagates less rapidly than a diesel flame. Therefore unless steps are taken to assist burning there is a greater risk of unburned fuel remaining at the end of the ignition stroke. Optimum piston crown and combustion chamber profiles need to be found to provide minimal unburned hydrocarbons, including avoiding possible quenching pockets by modifications to top ring design. In lean burn engines, gas swirl characteristics critically affect the HC emissions levels during operation near the lean misfire limit.

Electronic engine management systems are necessary for the precise control of air-fuel mixture, and rapid response to transient conditions. Electronic engine systems are rapidly increasing in processing capability, in line with general developments in computing technology. Parallel development of feedback sensors is a major area of research, particularly regarding fast response oxygen sensors. Adaptive control systems, capable of "learning" changing engine conditions, will provide accurate and fast closed-loop feedback operation for both lean burn and stoichiometric engines.

Intake manifold design is important for homogeneous fuel-air mixing, and it also influences combustion chamber swirl. In a diesel engine only air passes through the intake system, and there is no need for throttling. Future heavy duty natural gas engines will draw upon design principles similar to those used for high performance gasoline engines, in which air intake flows and fuel mixing are critical.

The future dedicated natural gas engine will require harder valve and valve seat materials. Stoichiometric engines will require high temperature piston alloys, and special piston cooling provisions. These features are all routinely provided on stationary engines, and in many cases manufacturers are able to provide the necessary technology directly from current production natural gas engines.

The dual fuel engine may decrease in popularity as dedicated gas engine development proceeds. The dual fuel concept remains attractive when it is necessary to retain the capability of operating on diesel. However, if the intention is to convert to natural gas permanently it would appear to be

better to pursue the optimization opportunities which can only be found in dedicated engines. A dual fuel engine can benefit from many of the technologies applicable to dedicated engines, but costs rise accordingly.

The relative advantages of lean burn and stoichiometric combustion will have to be more thoroughly investigated. At present it is not possible to predict whether one or the other may become dominant in future engine designs.

An important development, which may have far reaching effects on future heavy duty natural gas engine design, is direct injection of the fuel into the cylinder. Detroit Diesel has tested a two stroke 6V-92 engine which retains the diesel principle of operation. Gas is injected directly into the cylinder under a pressure of 20 MPa, and ignited by heat alone. A portion of the exhaust gas is retained in the cylinder to provide sufficient heat to obtain auto-ignition. The compression ratio is 23:1 and glow plugs are provided for starting. Detroit Diesel has successfully used this principle in methanol engines for over 6 years. The company has also built a similar engine which injects gas directly into the cylinder at a lower pressure during the early part of the compression cycle, before cylinder pressure has reached a maximum. This design has been tested with both spark ignition and pilot injection. The Detroit Diesel engine is a blower scavenged two stroke design, and some of the principles employed cannot be readily translated to a four stroke unit. Other organizations investigating direct injection of gas include Southwest Research Institute, which has operated a medium speed locomotive engine on this principle.

The fastest way to convert from the Diesel cycle to a natural gas Otto cycle, with good results regarding emissions, fuel economy, and conversion cost, is to choose lean-burn technology. Optimized lean burn engines provide very good driveability, and will be able to meet current and proposed emissions standards. Stoichiometric operation has proved itself in stationary applications and laboratory test projects, but is not yet feasible for the open market. Once effective control systems are available at series production price levels, stoichiometric heavy duty engines may become a viable future technology. This may happen before 1995. ORTECH International in Toronto, IMPCO in Los Angeles and Seattle, TNO in the Netherlands, and others are all working on dedicated natural gas systems.

Vehicles

The most pressing need at the current stage of natural gas heavy vehicle development is to find efficient ways of integrating the gas system components into the overall chassis and vehicle design. The main item of concern is the space required for fuel storage. The most promising paths of development are relocation of storage cylinders and the use of liquefied natural gas.

Roof mounting of cylinders on buses allows the use of very large individual cylinders. Buses in Europe tend to be designed for low passenger floor height, which makes it attractive to use space on top of the bus to locate the cylinders. Natural gas is lighter than air, therefore there is no danger from fuel leakage, and the risk of physical damage on top of the bus is minimal. From a technical point of view it is not difficult to store a considerable amount of gas on a bus roof. However, institutional barriers such as local fire and safety regulations, may be harder to overcome. The buses built by Ontario Bus Industries (OBI) for delivery to the cities of Toronto, Hamilton and Mississauga, use roof mounted cylinders. The buses designed for the Ravenna project in Italy have two large capacity cylinders mounted on the roof.

Roof mounting of cylinders is generally impractical for trucks, but the availability of lightweight cylinders in more shapes and sizes will allow better use of space along the chassis frame and behind the driver's cab.

Liquefied natural gas is particularly attractive for trucks and buses. Approximately 50% more fuel storage volume is required to provide the same range in comparison to diesel. Providing this much extra volume is not a problem on most medium and large size trucks and buses. There is rapidly increasing interest in the possibilities of LNG for heavy vehicles, and it seems probable that a significant proportion of future designs will use liquefied fuel. Adsorptive storage at present has many technical barriers to overcome, and is not viable for near to medium term use.

C. SUMMARY

Heavy duty trucks and buses represent less than 1,000 of the nearly 700,000 natural gas vehicles in operation around the world. Most of them are fitted with converted diesel engines, using diesel pilot injection or spark plugs as an ignition method. Natural gas is fumigated into the inlet manifold through a gas-air mixer. In a pilot injected (or dual-fuel) engine, the ratio of natural gas to diesel is increased as engine torque and power output increases. At idle the engine runs solely on diesel fuel. Pilot injection engines typically use around 70% natural gas and 30% diesel fuel during the overall operational cycle. Pilot injection is the simplest way of converting a diesel engine to burn natural gas. It also retains the ability to return to diesel only if necessary. However, it does not provide the maximum emission reduction advantages, and the maintenance of two separate fuel systems can be costly and inconvenient.

Spark ignited engines can be designed for either stoichiometric or lean-burn combustion. In both cases, only natural gas fuel is used, and the conversion is permanent. The gas supply is fumigated into the inlet manifold as for a

dual fuel engine. Stoichiometric operation is similar to the technology that is used in cars with three-way catalysts. It requires a very well developed control system, and a catalyst to provide the maximum emissions reductions. Results from laboratory tests and early over-the-road experience indicate that this technology has great potential. Lean burn technology takes advantage of the ability of natural gas to burn at very lean air-fuel ratios, providing inherently low NO_x emissions. HC emissions are cleaned up in an oxidizing catalyst. Spark ignited natural gas engines may provide longer service lives than conventional diesel engines, as the peak pressures and thermal loading tend to be lower, and the lubricating oil does not become as polluted.

The principle of directly injecting natural gas into the engine cylinder, and using heat alone to provide auto ignition, has been successfully demonstrated in laboratory engines. This may indicate important new development paths for the ideal heavy duty natural gas vehicle engine.

Natural gas burns slowly, therefore the combustion chamber and intake manifold need to be designed to assist rapid combustion. In addition, a control system providing fast and accurate feedback control of the air-fuel mixture needs to be developed. The optimized heavy duty engine will share many features in common with an optimized light duty engine. Development of ideal heavy duty vehicle engines is greatly assisted by the experience available from the stationary natural gas engine field.

Future heavy duty natural gas vehicles will use composite construction cylinders in a wide variety of sizes to provide maximum on-board fuel storage capacity. Interest in the use of liquefied natural gas, which requires approximately 50% more fuel storage space than diesel, is increasing. It is expected that a significant proportion of future trucks and buses will use LNG as a fuel. Many fleets have successfully operated natural gas buses and trucks for up to 10 years. All of the major international engine manufacturers have natural gas development programs, and engines are available on a pre-production basis. The number of heavy duty natural gas vehicles in service is expected to grow considerably in the near to medium term future.

VII EMISSIONS

A. ENVIRONMENTAL AND HEALTH ISSUES

Air pollution has increased substantially over the last 50 years due to human and industrial activities. Increased air pollution has caused problems on a local level, especially in urban areas; regionally, often beyond national frontiers; and globally, affecting the planet as a whole. The principal causes are the tremendous increase in the use of man-made chemicals, and combustion of fossil fuels. Consequences of this development are the observed risks of damage to human health and the environment. Risks of exposure to pollution are no longer limited to small groups of the population. Long-range transport of pollutants has led to increased pollution levels and a greater exposure at sites remote from the pollution source.

Since the 1970s, many countries have passed laws and regulations in an effort to stabilize, or even reverse, deterioration in air quality. However, due to increased industrial output and population growth, these rules have only had the net effect of slowing the rate of increase of the release of pollutants. The problem still persists.

The impacts of air pollution and deposits from polluted air on the soil and water can be divided as follows:

- Human health damage due to carbon monoxide, sulphur dioxide, nitrogen dioxide, ozone, soot and particulates; for which limits have been set by the World Health Organization (WHO) and national agencies;
- Carcinogenic effects due to long time, low level exposure to genotoxic substances including gaseous olefins, benzene, aldehydes, polycyclic aromatic compounds (often carried on particulates), and, possibly, nitrogen dioxides;
- Damage to crops and forests due to ozone and nitrogen oxides;
- Acidification of lakes by sulphur and nitrogen oxides; and
- Greenhouse effects due primarily to carbon dioxide, methane, nitrous oxide and chlorofluorocarbons.

Anthropogenic (man-made) sources of sulphur dioxide emissions include combustion of oil and coal by utilities. Sulphur dioxide concentrations are proportional to fuel sulphur content. Total anthropogenic sources of sulphur

dioxide emissions are about equal to the natural occurring sources of sulphur dioxide. Road traffic makes only a small contribution to total sulphur dioxide emissions. This source can easily be reduced through improved fuels.

Road traffic is the primary anthropogenic source of carbon monoxide emissions. Overall, man-made sources account for about one third of all atmospheric carbon monoxide. A recent downward trend in emissions of carbon monoxide reflects, to a great part, the introduction of emission controls on vehicles.

The major anthropogenic source of particulate matter is fuel combustion. Particulate matter less than $2.5\mu\text{m}$ diameter can penetrate into the lungs. Diesel engines are a primary source of particulate emissions, producing a greater amount of particulate, on a per energy basis, than gasoline engines. There is concern over diesel derived particulate matter, as opposed to natural dust, because of the particulate make up: elemental carbon (soot), sulphates and polycyclic aromatic hydrocarbons (PAH). There is also a carcinogenic risk associated with PAH. An observed reduction in particulate emissions is partly due to installation of dust removal equipment on many industrial process plants, but this has been partly offset by increased emissions from increased use of diesel powered vehicles. This is especially true for the finest, inhalable particles.

Nitrogen oxides (NO_x), are the product of combustion. In addition, they are agents in many air chemistry reactions, leading to harmful compounds in the air. NO_x is mainly emitted as nitric oxide (NO), which in the atmosphere is oxidized to the more toxic nitrogen dioxide (NO_2). Nitrogen dioxide when mixed with water vapour forms nitrous and nitric acid. Road traffic accounts for approximately 50% of NO_x emissions in industrialized countries. Emissions in most countries are rising. Natural emissions, from the decay of organic matter in soil and water and from natural fires, may be significant but they are to a large extent in the form of di-nitrogen oxide, which is non-reactive in the lower atmosphere. It is, however, a greenhouse gas.

Volatile Organic Compounds (VOCs) comprise a great number of compounds, some of which are highly reactive in oxidant formation and some which are toxic. Methane is the least reactive hydrocarbon. It is also the most abundant hydrocarbon, due mainly to natural processes, such as anaerobic decomposition in wetlands. Emissions do, however, appear to be related to human activities including landfills, livestock and manure, and use of fossil fuels. The atmospheric methane content has been rising with world population. This can be attributed to enteric fermentation from domestic herds and the cultivation of rice paddies.

Local Effects

Standards or guidelines for air quality covering sulphur dioxide, nitrogen oxides, carbon monoxide, ozone, and particulate matter (especially the smallest particles) are frequently exceeded, especially along heavily travelled roads, leading to health effects and damage to plants and trees.

Cancer incidence due to polluted urban air, to which road traffic is a major contributor are according to Swedish estimates, 2 cases (1 lethal) per 10,000 persons per year. This risk corresponds to the upper limit accepted for occupational radiation exposures and is 10 to 100 times higher than an acceptable risk for individuals in urban areas.

Deposition of acid compounds also damages buildings and monuments, endangering our cultural heritage. Corrosion of concrete and steel structures may become a severe problem. Synergistic effects between sulphur and nitrogen oxides enhance all these types of damage.

Regional Effects

Ecological effects are mostly related to the total exposure and deposition over a long period of time. They are also influenced by pollutants transported from far away sources. Effects of nearby deposition of nitrogen oxides have been observed along heavily travelled highways. Sulphur, nitrogen oxides and ozone disturb the photosynthesis cycle. Deposits of these compounds acidify soil and water, leading to damage to forestry and fisheries.

If acidification goes too far, nutrient salts could be leached out. Any aluminum that is liberated will exacerbate the damage. If the acidic deposition is greater than what the soil can absorb, i.e., the critical load, nitrogen compounds will leak into ground water and waterways causing abnormal growth of micro-organisms. Irreversible flora changes have already taken place and damage to forests and lakes is rapidly occurring in areas with soils of low buffering capacity.

Conclusions - Role of Methane as Motor Fuel

Worldwide cooperation is required to effectively deal with air quality problems. Air pollution is not restricted to distinct geo-political boundaries. Air quality management is best handled from a transboundary approach. For the transportation sector, which includes both fuels and vehicles, this means better enforcement of existing national regulations and policies, and rigorous implementation of international agreements. It is recognized that present emission standards are insufficient to reverse the trend of increasing environmental and health damage. Much more stringent standards will have

to be adopted. In the future, toxic compounds will also likely be regulated. The U.S., and in particular, California have signalled their intention to regulate in this area.

Alternative motor fuels, such as methane and methanol, can play a crucial role in this development. Although the data base is not yet complete, existing data shows that the use of methane as a fuel will result in lower carbon dioxide and greenhouse gas releases, particularly if natural gas that is now flared and biogas that is now vented from garbage dumps is utilized. Higher methane content exhaust gas, while more difficult to reduce in present catalytic systems, will not change this conclusion. Most fuel-related genotoxic compounds are virtually eliminated by using methane as fuel.

B. REGULATORY RESPONSE

Test Methods

With a trend towards more stringent emissions standards, vehicles and engines require a significant level of emissions control. The exhaust emissions profile is no longer strictly a function of fuel type. It is also a function of engine design, engine calibration and the emissions control system.

Motor vehicle exhaust emissions are regulated on a mass basis. Individual countries impose standards restricting the maximum permissible emissions rates of exhaust species, which can include hydrocarbons (HC), carbon monoxide (CO), nitrogen oxides (NO_x), and in some cases particulate matter. However, there is still a great degree of diversity in the approach and standards enacted by different countries.

Different test methods have been developed around the world to fill the function of comparing exhaust emissions and to create an instrument for legislation.

Two basic kind of test methods are used. Exhibit VII-1 summarizes some transient (including accelerating and decelerating) and steady state test methods.

All test cycles were created to represent typical cycles of road operation.

The most commonly used, and most criticized, cycles are the U.S. Federal Test Procedure (FTP) and Economic Commission for Europe, Regulation 49 (ECE R49) methods. The FTP method is the North American method to certify a light duty vehicle or a heavy duty engine in order to obtain approval for its use. Criticism is related to the emphasis given to engine operating

modes that are rarely seen in actual service. Secondly, most test cycles, including the FTP and ECE R49, are such that engine optimization can take place specifically to meet the test cycle requirements rather than over-the-road requirements. The ECE R49 test focuses on idling and rated power at 40% speed. Engines that are designed to meet stringent exhaust emission targets are optimized mainly for these two points.

Exhibit VII-1. Commonly Used Emissions Test Cycles

Transient	Steady State
FTP (U.S. Federal Test Procedure). New York Bus Cycle. Braunschweig.	ECE R49 (Economic Commission for Europe, Regulation 49). ECE R15 . U.S. 13 mode. Japanese 6 mode. Japanese 10 mode. Uppsala bus cycle.

In the case of heavy duty engines, an FTP cycle takes 20 minutes to execute and must be performed twice. The first test is a cold start (below 20 degrees C), followed by a test with a warm engine exactly 20 minutes after the cold start test has been finished. The final results consist of a weighted sum of cold (1/7) and hot (6/7) start results. North American regulations cover carbon monoxide, hydrocarbons, nitrogen oxides and particulate emissions.

ECE R49 (Economic Commission for Europe, Regulation 49) is a stationary 13 mode cycle. This method is used for legislation in Europe as well as other parts of the world.

The method includes 13 measurements performed at 11 different speed/load points (idling is measured three times). All modes are hot modes. The engine is run for six minutes at each speed/load point, of which only the last minute is accounted for. Japan has a six mode cycle test that is conducted in a similar fashion.

Individual standards are not always comparable between nations, even amongst those employing the same approach. Differences can arise in their respective test procedure, deterioration factor, and vehicle or engine classification. An example of this is the rules applicable in the State of California and those in the remainder of the U.S.A. (49 States). On the

other hand, West European countries, especially those within the EEC, have all adopted the ECE R49 test method, which makes country specific rules comparable.

Application To Natural Gas

The North American (U.S.A., California and Canada) approach has been to develop fuel specific emissions standards. These currently encompass gasoline and diesel fuel, as well as methanol in the U.S.A. and California. Presently, only the State of California has adopted emissions standards specific to natural gas powered heavy duty vehicles. The lack of natural gas vehicle emissions standards does not prohibit the entry of natural gas vehicles into the U.S. or Canadian market place.

Countries adhering to EEC style standards, and in particular the European (Scandinavian) countries, have adopted a broad based approach. Emissions limits prescribed in their standards are fuel independent. In other words, a manufacturer may elect to sell a product that uses any type of fuel, provided that it meets certification standards.

Recent Trends

The United States, and in particular the State of California, are generally regarded as global trend setters for emissions regulations. Recent amendments to the U.S. Clean Air Act (CAA), passed in October 1990, mandate more stringent standards for new motor vehicles, effective beginning in model year 1994. Standards under Tier 1 of the CAA amendment, which may cause automobile and engine manufacturers to more closely examine natural gas powered vehicles, include the introduction of a non-methane hydrocarbon (NMHC) standard, a cold temperature CO standard for light duty vehicles, and implementation of a 0.05 g/bhp-hr particulate standard for urban transit buses. Exhibits VII-2 and VII-3 highlight pending changes to U.S. rules. U.S. Federal rules still do not cover gaseous fuelled vehicles. The United States Environmental Protection Agency (EPA), under a separate rule making, is also considering including gaseous fuelled vehicles in its regulations.

The U.S. CAA Amendments also directed the EPA to initiate action towards a more stringent standard for NO_x from heavy duty engines. This proposed standard would be 4.0 g/bhp-hr beginning in model year 1998. The EPA will also examine the need, feasibility and cost of more stringent automobile and light duty truck standards. Currently suggested standards, termed Tier 2 are 0.125 g/mile non-methane hydrocarbon (NMHC), 1.7 g/mile carbon monoxide (CO), and 0.2 g/mile oxides of nitrogen (NO_x). The proposed time frame to introduce these standards will be between model year 2002 and 2006.

**Exhibit VII-2. Comparison of Passenger Car
Emission Standards Under the U.S.
Clean Air Act (Tier 1)**

Emissions Constituent	USA Today	U.S. Clean Air Act Amendments (Effective 1994)	
		At 50,000 Miles	At 100,000 Miles
		(g/mile)	(g/mile)
THC	0.41	0.41	0.41
NMHC	None	0.25	0.31
CO	3.4	3.4/10.0 (1)	4.2
NO _x	1.0	0.4	0.6

(1) Cold Temperature standard at -7°C

(Source: SYPHER)

**Exhibit VII-3. Comparison of Heavy Duty Diesel
Engine Emission Standards Under the
U.S. Clean Air Act (Tier 1)**

Implementation Year	Vehicle Category	Emissions Constituent (g/bhp-hr)		
		No _x	PM	
Current	In-effect	All	6.0	0.60
U.S. Tier 1	1993	Trucks	5.0	0.25
	1993	Buses	5.0	0.10
	1994	Trucks	5.0	0.10
	1994	Buses	5.0	0.05 (0.07)*

Following standards remain in effect:
 HC = 1.3 g/bhp-hr
 CO = 15.5 g/bhp-hr

* If manufacturers can demonstrate the more stringent standard is not feasible.

The State of California recently unveiled plans for the later 1990s and into the next century. The Low Emission Vehicle (LEV) and Clean Fuel Plan seeks to severely limit and eventually eliminate reactive HC emissions from all motor vehicles, irrespective of fuel type. The plan seeks to achieve this goal by encouraging the introduction of "clean" fuels, including natural gas, through the introduction of non fuel-discriminatory standards. The California plan is specifically designed to address the severe ozone problem and the general problem of air toxics.

Under the LEV plan, a non-methane organic gas (NMOG) standard would be used in place of the present mass limiting fuel specific NMHC standard. The NMOG approach considers both the non-oxygenated hydrocarbons such as those currently measured, as well as the oxygenated fraction, such as aldehydes. In order to equalize the air quality impact from different fuels, the measured NMOG portion of the exhaust gas would be adjusted by a factor that accounts for the photochemical reactivity of the exhaust. The net NMOG factor for a given fuel type would be the product of these two numbers. This net NMOG factor would be compared with the standard to verify compliance. This approach seeks to limit the ozone forming potential of vehicles fuelled by different fuel types. Hence, a natural gas engine should benefit under this scheme since the majority of its exhaust is composed of methane, leading to a low reactivity adjustment factor.

Exhibit VII-4. Passenger Car Emissions Standards Under the California Plan³⁵ (g/mile)

Category	NMOG	CO	NO _x	PM	Formaldehyde
TLEV	0.125 (0.156)	3.4 (4.2)	0.4 (0.6)	(0.08)	0.015 (0.018)
LEV	0.075 (0.090)	3.4 (4.2)	0.2 (0.3)	(0.08)	0.015 (0.018)
ULEV	0.040 (0.055)	1.7 (2.1)	0.2 (0.3)	(0.08)	0.008 (0.011)

Notes:

- 50,000 mile standards.
- () denotes 100,000 mile standards.
- all standards in g/mile.
- Particulate matter (PM) standards only apply to diesel fuelled vehicles.
- TLEV denotes transitional low emission vehicle.
- LEV denotes low-emission vehicle.
- ULEV denotes ultra low emission vehicle.

³⁵ California Air Resources Board, "Proposed Regulations for Low Emissions Vehicles and Clean Fuels - Technical Support Document", August 13, 1990.

Under the LEV plan, individual manufacturers would be given latitude to certify any mix of vehicles which meet the fleet average NMOG standard. The fleet mix could consist of transitional low emission vehicles (TLEV), low emission vehicles (LEV), ultra low emission vehicles (ULEV) and zero emission vehicles (ZEV). Only the passenger car and light duty truck category would be mandated to maintain a sales fraction of at least 10% ZEVs by 2003. Exhibits VII-4 and VII-5 summarize passenger car emissions standards under the LEV plan.

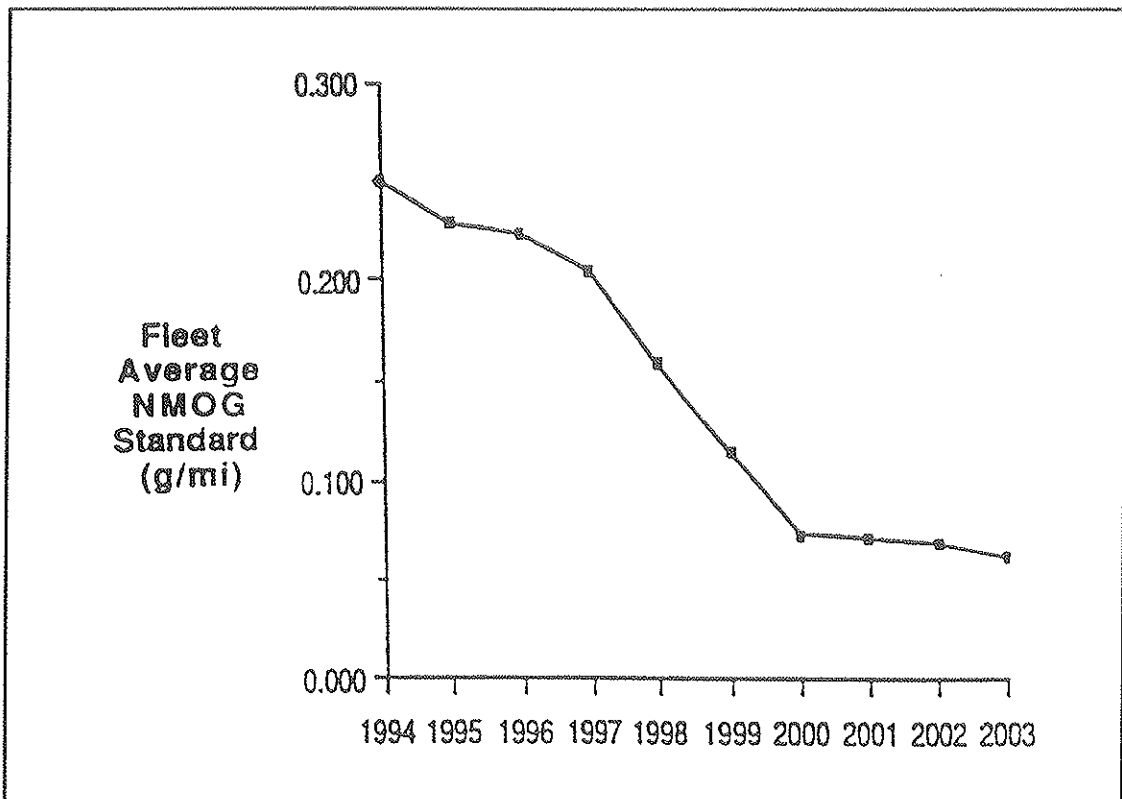

Exhibit VII-5. Proposed Fleet Weighted Average NMOG Standard

It should be pointed out that the LEV plan does not negate acceptance of methane emission limits. Future amendments to the plan may attempt to address methane as well as other greenhouse gases.

Summary

There is still a great deal of discrepancy in emissions standards between different countries throughout the world. There does not appear to be any opportunity for convergence of emissions standards in the near future. The modal and steady state ECE test cycles are particularly appealing to "developing" nations since such test cycles can be implemented at relatively low cost compared to the transient test cycle developed by the U.S.A.

Recent regulatory initiatives in California and the U.S. will give further impetus to natural gas engine development. Pending regulations in both regions seek to severely curtail motor vehicle emissions.

C. EXHAUST EMISSIONS - OVERVIEW

Regulated emissions

Optimized dedicated natural gas engines should offer emissions reductions compared with conventional fuelled vehicles available today. Similarly, dedicated natural gas engines should also offer emissions reductions compared to the bi-fuel natural gas engines that are currently available.

Natural gas, unlike either gasoline or diesel, primarily consists of methane (CH_4), a single carbon molecule gaseous fuel. Natural gas, as delivered to users, also contains little if any sulphur or toxic materials and is therefore less likely to produce them in the exhaust.

Exhibit VII-6 illustrates the relationship of regulated exhaust gas constituents (HC, CO and NO_x) as a function of the normalized air-fuel ratio for a spark ignited engine. An understanding of some of the factors affecting emissions composition will aid in understanding the different combustion technologies applied by designers of natural gas engines.

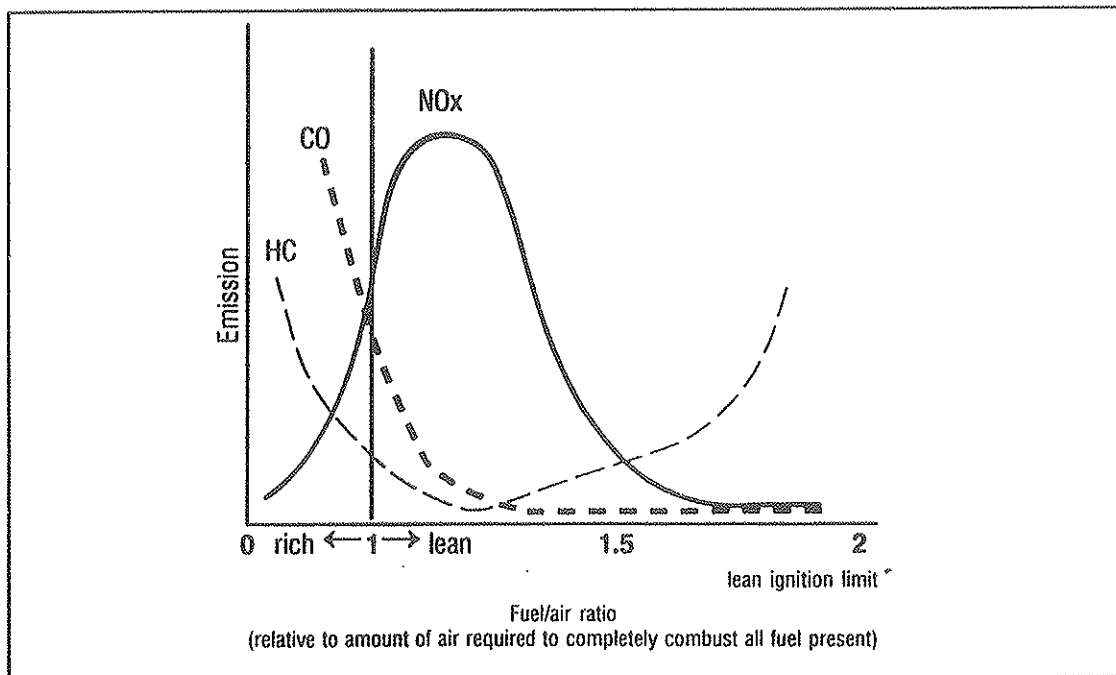

Exhibit VII-6. Emissions Trends as a Function of Air-Fuel Ratio³⁶

36 Weaver, C.S.; - op cit. Figure 7.

Referring to Exhibit VII-6, hydrocarbon emissions have a characteristic U shape and tend to rise under either very rich or very lean conditions. HC formation tends to be a function of available air and overall air fuel mixing. A minimum quantity of air is required to sustain combustion. If the mixture is too rich, then unburned and partially combusted fuel will be ejected in the exhaust. HC emissions can also occur when the CH₄ concentration is too low and the flame front is quenched. This can occur at the extremities of the combustion chamber where the relatively cool cylinder walls extinguish the flame front before combustion is completed. By the same token, HC emissions climb under ultra lean conditions if there is insufficient fuel to sustain combustion. Engine misfire occurs under these conditions. Pockets of unburned fuel in the combustion chamber can contribute to high HC emissions.

Exhaust hydrocarbon composition is a function of fuel composition. HC emissions from a natural gas engine primarily consist of methane, which has an extremely low reactivity. Therefore, HC emissions from a natural gas engine should be less photochemically reactive than an equivalent mass of HC emissions from a gasoline or diesel vehicle. Under ideal conditions, the non-methane hydrocarbon (NMHC) exhaust from a natural gas vehicle should be proportional to the NMHC content of the feed gas. In practice, the combustion of lubricating oil within the cylinder adds other NMHC elements to the exhaust stream. However, the photochemical reactivity of the NMHC portion of natural gas engine exhaust is expected to be much less reactive than exhaust from a conventionally fuelled vehicle. Non-methane hydrocarbon exhaust from a natural gas vehicle will primarily consist of light paraffins such as ethane and propane, which are less reactive than the NMHC from liquid petroleum fuelled vehicles.³⁷ Recent data suggests that the ozone reactivity factor of NMHC exhaust from a dedicated NGV vehicle would only be 0.36 times as reactive as the NMHC portion from a gasoline vehicle.³⁸

Aldehydes, primarily in the form of formaldehyde, have been detected in the exhaust of natural gas vehicles. Aldehydes tend to be formed as an intermediate product of combustion due to quenching of a partially reacted

37 "Definition of a Low-Emission Motor Vehicle in Compliance with Mandates of Health and Safety Code Section 39037.65" (Assembly Bill 234, Leonard, 1987). California Air Resources Board. May 19, 1989.

38 Air Resources Board, State of California; "Staff Report: Initial Reasons for Proposed Rulemaking - Public Hearing to Consider Amendments of Regulations to Establish Certification Standards and Test Procedures for New Heavy Duty Vehicles and Engines Fueled With CNG or LPG." Date of Release: July 28, 1989.

mixture.³⁹ TNO in Holland reports 3 to 4 times the formation of formaldehyde compared with gasoline operation. Formaldehydes are reduced considerably in almost any catalyst. The U.S. EPA reports that formaldehyde levels from natural gas vehicles with catalysts should be no higher than those from comparable gasoline vehicles.⁴⁰

Carbon monoxide emissions are also an indicator of overall combustion quality and available oxygen. At rich conditions, incomplete combustion gives rise to high CO levels. With increasing air, as depicted in Exhibit VII-6, enough oxygen is available to sustain combustion, hence CO emissions diminish. Even at the lean ignition limit, there is enough air to support combustion.

Natural gas is in a gaseous state at ambient conditions. This offers an important advantage during cold starting, since it can be distributed throughout the combustion chamber in a gaseous state. Liquid fuels tend to condense on cold surfaces creating pockets of excessively rich mixtures which result in incomplete combustion. Liquid fuel can also flush lubricating oil from the cylinder walls, leading to accelerated cylinder wear. Cold starting accounts for approximately 50 to 70% of engine wear in a light duty vehicle engine. Emissions generated during cold start and warm up will become increasingly important to engine designers, particularly as emissions standards become more stringent.

Nitrogen oxides (NO_x) formation is a function of combustion temperature, combustion time, and available oxygen. NO_x is reduced under conditions of very rich or lean mixtures because of incomplete combustion and excessive air, respectively.

Particulates are not known to be formed from methane, but natural gas may contain some sulphur or other substances that can create small quantities of particulate.

Soot may be formed if the flame is cooled rapidly. Direct injected engines have shown increased soot formation in stationary applications. However, this should not be pose a problem if the engine design is optimized.

³⁹ Weaver, C.S. (Sierra Research Inc.); "Natural Gas Vehicles - A Review of the State of the Art." SAE paper 892133.

⁴⁰ United States Environmental Protection Agency; "Analysis of the Economic and Environmental Effects of Compressed Natural Gas as a Vehicle Fuel - Passenger Cars and Light Trucks." Volume 1. Special report from the Office of Mobile Sources (no report number). April 1990.

Particulate emissions from natural gas vehicles can come from two sources:

1. Lubricating oil. Piston ring design and lubricating oil control on natural gas engines must be optimized.
2. The amount of diesel oil in a dual-fuel process. Particulate output is directly comparable with the diesel fuelling rate.

Engines can be designed to operate around either a stoichiometric condition or a lean condition. Both the stoichiometric and lean burn engine offer distinct advantages in terms of emissions, performance and fuel consumption.

The technology for stoichiometric engine control is widely utilized on modern gasoline engines. Although NO_x emissions tend to be near peak levels, this type of engine and catalyst control has been successfully transplanted onto prototype natural gas engines, although at high cost. The nature of stoichiometric control permits optimum treatment of exhaust HC, CO and NO_x via catalytic means, while permitting a power advantage in comparison with a lean burn approach. Stoichiometric operation also offers the advantage of greater power output than lean burn for a given engine displacement.

The future challenges facing engine developers seeking to produce an optimized stoichiometric natural gas engine include: development of a catalyst with good CH_4 and NO_x control over a wide operating range; and a closed loop control system capable of tight air-fuel ratio control.

Lean burn technology permits NO_x control at the source. Due to the oxygen rich atmosphere in the exhaust gas, no further NO_x reduction can be achieved via catalytic means. HC and CO emissions reductions can be achieved through oxidation catalysts. A lean burn set up will also require a good CH_4 oxidation catalyst as well as a precise engine control system. However, the fuel metering system does not have to be as precise as for stoichiometric operation. In this case, the A/F ratio control system must maintain operation just inside the lean limit to avoid engine misfiring. This should help control the cost of fuel metering systems on lean burn engines.

Air Toxics

In addition to the regulated emissions of HC, CO and NO_x , air toxics have been receiving increased attention. Air toxics found in motor vehicle exhaust include benzene, 1, 3 - butadiene, aldehydes and particulates. These contaminants are present in diesel and gasoline vehicle exhaust. In a recent CARB study to evaluate the risk of 11 known or suspected motor vehicle air toxics, benzene, 1, 3 - butadiene, diesel particulates, formaldehyde and acetaldehyde were identified as contributing to 99% of the cumulative

California cancer cases attributable to motor vehicles.⁴¹ Dedicated natural gas powered vehicles offer the opportunity to significantly reduce toxic emissions. Particulate emissions, as will be illustrated further on, will be virtually eliminated. Natural gas contains no benzene, therefore exhaust emissions of benzene; would be limited to combustion of lube oil. Similarly, emissions of 1, 3 - butadiene should be virtually eliminated.

Dedicated natural gas powered vehicles will also eliminate lead emissions. Although some countries have eliminated lead from gasoline, lead can still be found in gasoline throughout much of the world.

D. EXHAUST EMISSIONS FROM LIGHT DUTY VEHICLES

The technology for producing natural gas vehicles has been around for many years. Historically, almost all natural gas vehicles have been based on after market conversions. Most of the engines falling into this category have been bi-fuel engines; gasoline and CNG. These engines tend to be characterized by stoichiometric combustion with mechanical carburetion systems for natural gas introduction.

Bi-Fuel

Bi-fuel operation permits extended range at the expense of emissions optimization. Exhibit VII-7 contains emissions results from tests performed by the U.S. EPA and the California Air Resources Board (CARB).

Referring to Exhibit VII-7, vehicles exhibited an increase in total HCs while operating on natural gas compared to gasoline. However, most of the increase in hydrocarbons can be attributed to methane, i.e., unburned fuel. Overall, NMHC's are expected to decrease compared with gasoline emissions. The NMHC fraction present with natural gas operation can be attributed to lubricating oil combustion. As a rule of thumb, the NMHC fraction can account for up to 10% of THC.

Natural gas offers the opportunity for significant reduction in CO emissions. Results in Exhibit VII-7 indicate that CO emissions decreased by an average of 87% when a vehicle was operated on natural gas. The reduction can be attributed to the more uniform air-fuel mixing obtained. However, the observed CO reductions are not solely the result of a switch to natural gas. Of three vehicles tested by the EPA in an "as-received" condition, one exceeded the CO standard and the other two posted CO emissions results

⁴¹ State of California - Air Resources Board; "Motor Vehicle Toxics: Assessment of Sources, Potential Risks and Control Measures", June 1989.

**Exhibit VII-7. Emissions from Light Duty
Natural Gas/Gasoline Bi-Fuel Vehicles^{42,43}**

Vehicle/Fuel System	Fuel Type	THC (g/mile)	NMHC (1) (g/mile)	CO (g/mile)	NO _x (g/mile)	Formaldehyde (mg/mile)
CNG Fuel System/ 1984 Oldsmobile Delta 88(2)	Gasoline	0.4	0.3	9.8	0.40	4.0
	Natural Gas	2.5	0.25	1.7	1.18	4.8
Total Fuels/ 1987 Ford Crown Victoria(2)	Gasoline	0.4	0.27	1.4	1.07	NA
	Natural Gas	3.6	0.36	0.5	0.93	NA
Wisconsin Gas/ 1987 Chevrolet Celebrity (2)	Gasoline	0.3	0.2	1.3	0.6	NA
	Natural Gas	1.6	0.16	0.1	1.19	NA
Bi-Fuel System/ 1983 Ford LTD (3)	Gasoline	0.5	0.36	3.3	0.56	NA
	Natural Gas	3.5	0.35	0.1	0.47	NA
Pacific Light/ 1985 GMC Pickup (3)	Gasoline	0.4	0.26	7.0	0.7	NA
	Natural Gas	0.5	0.05	0.2	1.06	NA
U.S. Standard (4)		0.41	--	3.4	1.0	--
U.S. Standard (5)		0.41	0.25	3.4	0.4	--

Notes:

- (1) NMHC values estimated in EPA test results. NMHC fraction assumed to be 75% of THC from gasoline and 10% from natural gas.
- (2) Vehicle tested by U.S. EPA.
- (3) Vehicle tested by California ARB.
- (4) Current Standard (set in 1988).
- (5) Under CAA Amendments, effective 1994.

⁴² Ibid page 14.

⁴³ United States Environmental Protection Agency; - op. cit. Table 9.

that were better than those recorded with gasoline. The CO emissions, reported in Exhibit VII-7, were reduced following recalibration of the fuel system to natural gas. The implication is that an improperly tuned fleet operating on natural gas may produce greater CO emissions than an identical fleet using conventional fuel with proper engine tuning.

Nitrogen oxide results tended to be mixed. Depending on the air-fuel ratio, spark timing, catalyst, etc., NO_x emissions can increase or decrease with natural gas compared to gasoline. The EPA concludes that it expects NO_x emissions to increase with natural gas compared to gasoline. This can in part be attributed to the higher peak combustion temperature of methane. Advanced spark timing is also generally used to compensate for the slower flame speed of natural gas.

Exhibit VII-8. Comparative Emissions From 1990 Ford Taurus Cars Operating on Natural Gas and Gasoline⁴⁴

Fuel/Standard	THC (g/mile)	NHMC (g/mile)	CO (g/mile)	NO _x (g/mile)	Formaldehyde (mg/mile)
1988 Standard	0.41	3.4	1.0	-	-
Proposed 1994 Standard	0.41	3.4	0.4	0.25	-
Gasoline	0.18	1.56	0.53	0.23	4.66
Natural Gas ¹	0.89	1.11	2.54	0.10	11.91
Natural Gas ²	1.11	2.08	1.04	0.13	9.20

¹ Test carried out after "Cross-Canada" test run.

² Test carried out after tune-up.

As shown in Exhibit VI-8, emissions testing of a 1990 Ford Taurus by Environment Canada in 1990 found results similar to those of the EPA and CARB. The NMHC emission rates for the natural gas conversion were approximately one-half the emission rate for an otherwise identical gas car although total hydrocarbons were higher. CO emission rates were dependent on engine tuning. The NO_x emissions for the natural gas cars were two to five times higher than the gasoline car, depending on the tuning of the engine.

The results presented so far have been for conventional natural gas mixer technology. Improvements are expected with new gaseous fuel injection

⁴⁴ Prakash, C.B., "Emission Performance of Four Identical Passenger Cars Running on Gasoline, M85, CNG and LPG", 84th Annual Meeting of the Air and Waste Management Association, Vancouver, 16 - 21 June 1991.

systems. As a result of development testing, Ortech International has predicted that their GFI technology should be able to achieve emissions levels in the TLEV to ULEV range with enhanced engine and emission controls.

While results point to NMHC and CO reductions with natural gas, the overall reduction is limited with a bi-fuel vehicle. The emissions performance is a function of the particular kit and the expertise of the person who installs it. The design also represents a compromise for driveability while operating on either fuel. Because driveability may not be affected, a driver may be unaware that the engine is operating off specification, producing excessive emissions.

With emissions and overall efficiency becoming driving forces, a bi-fuel vehicle is more likely to play a transitional role in the market. The long term scenario includes optimized dedicated natural gas light duty vehicles. Under such circumstances, regulated and toxic emissions are expected to be reduced. North American OEM's are expected to demonstrate such vehicles starting around 1992/93.

Dedicated Natural Gas

A dedicated natural gas engine offers the opportunity for an engine design that is optimized for low emissions and high efficiency. There have been very few publicized attempts to design and build an optimized natural gas powered vehicle. Data in Exhibit VII-9 contains emissions results from tests conducted on CNG and LNG vehicles as well as forthcoming emissions standards for light duty trucks under Tier 1 of the U.S. CAAA. Although there are limited results available, the data is encouraging.

The results for the Ford Ranger pick-up truck are noteworthy, since it represents an early 1980's OEM attempt to build an optimized CNG vehicle. The work was undertaken in conjunction with the American Gas Association (AGA) between 1983 and 1984. The design goals included satisfying the 1984 U.S. emissions standard for light duty vehicles. Ford eventually produced 24 of these vehicles.

The CNG version of the Ford pick-up truck achieved a 99% reduction in CO emissions and a 30% reduction in NMHC emissions compared with the baseline gasoline version of the vehicle. The CO and NMHC emissions from the truck, at 0.03 and 0.14 g/mile respectively, are well within the 1994 standards, of 3.4 g/mile and 0.25 g/mile, respectively proposed under the CAA. Although NO_x emissions did increase by 70% compared to the baseline gasoline engine, they were still within the NO_x emissions standard of

2.3 g/mile, in force at the time. Results from the Dodge Van are equally encouraging. The Dodge van was converted over to CNG using a three way catalyst and a closed loop control system manufactured by Clean Fuels Inc. The NMHC and CO emissions results, at 0.15 and 0.97 g/mile; respectively, were well within promulgated 1994 standards. NO_x emissions, at 0.68 g/mile is just within the 0.70 g/mile standard. Total hydrocarbon emissions, primarily composed of methane, reached 1.57 g/mile which exceeds the U.S. Tier 1 standard of 0.80 g/mile. Possible emissions reductions techniques include increases in compression ratio, optimized spark timing and improvements in catalyst conversion efficiency.

Exhibit VII-9. Dedicated LDV Emissions Results^{45,46,47}

Vehicle	Fuel Type	NMHC	CO (g/mile)	NO _x
1984 Ford Ranger (1)	Natural Gas	0.14	0.03	1.9
	Gasoline	0.2	3.2	1.1
Applicable Emissions Standards (at 50,000 miles)		0.25	3.4	0.4
1989 Dodge Ram Van (2, 3)	Natural Gas	0.15	0.97	0.68
	Applicable Emissions Standards (at 50,000 miles)	0.32	4.4	0.7
1980 Vehicle (2)	LNG	0.46	7.85	3.53

Notes: (1) Tested by Ford Motor Company.

(2) Tested by U.S. EPA.

(3) Equipped with Clean Fuels Inc., CNG conversion and 3-way catalyst..

⁴⁵ United States Environmental Protection Agency; -op-cit.

⁴⁶ Deluchi, M.A., et al (University of California); "Methanol vs. Natural Gas Vehicles: A Comparison of Resource Supply, Performance, Emissions, Fuel Storage, Safety, Costs and Transitions." SAE paper 881656.

⁴⁷ Gabele, P., et al (U.S. EPA) and Snow, R., et al (NSI Inc.), "Ambient Temperature and Driving Cycle Effects on CNG Motor Vehicle Emissions". SAE Paper 902069.

These preliminary results, although limited in scope, appear to indicate that dedicated natural gas vehicles should be able to satisfy the NMHC and CO standards promulgated under Tier I of the U.S. Clean Air Act Amendments. Nitrogen oxides and total hydrocarbon emissions may pose a minor barrier to NGV vehicle certification under Tier 1 of the U.S. CAAA. Further NO_x and THC reductions are expected. Tier 1 rules impose both a THC and a NMHC standard.

Cold Start Emissions

Greater attention is being focussed on cold start emissions. An example is a cold temperature (-7°C) CO standard, applicable to light duty vehicles under Tier 1 of the U.S. CAAA.

Cold start emissions are those emissions occurring immediately following engine start up, before the exhaust catalyst has reached its light off temperature. Unlike gasoline or methanol vehicles, which exhibit substantial increases in organic emissions and CO at lower temperatures, NGV emissions appear almost unaffected by temperature. This is because natural gas exists in a gaseous state at all normal ambient pressure, and temperatures. Therefore the fuel can be evenly distributed throughout the cylinders. Furthermore, there is no need for cold start enrichment. Results from a series of tests conducted by the EPA indicate that THC, NMHC and CO emissions remain stable when the starting temperature is dropped from 24°C to -7°C. Only formaldehyde was found to increase (to 9.2 mg/mile from 5 mg/mile) when the starting temperature was reduced. The increase in formaldehyde emissions can be attributed to incomplete combustion. However, the catalyst provided a 95% reduction in formaldehyde emissions.⁴⁸

E. EXHAUST EMISSIONS FROM HEAVY DUTY VEHICLES

Natural gas has been used in stationary engines and in a limited number of mobile applications for many years. These applications consisted of engine conversions by OEMs and after-market equipment suppliers. Engine design approaches have included both dedicated natural gas and dual-fuel (diesel - natural gas). The reasons for engine conversion were analogous to the case of light duty engines. Only since the mid 1980s has a sustained effort been directed towards developing an optimized natural gas heavy duty vehicle engine. This has been driven by more stringent heavy duty diesel particulate and NO_x emissions standards in the U.S.A., and by public pressure in some West European countries like the Netherlands, Sweden and Switzerland.

⁴⁸ Gabele, P.; - op cit.

Researchers have been examining both dual-fuel and dedicated natural gas versions. However most of the R&D and recently published emissions related work has been directed towards dedicated natural gas engines, given the stringency of current and future regulations.

Pilot Injection And Fumigation

The diesel/natural gas mixture approach has been an attractive route for those interested in a relatively low cost modification. However diesel fuel combustion is never completely eliminated, therefore the engine is more likely to produce a greater portion of NMHCs as well as particulates compared with dedicated natural gas operation. Long term catalyst efficiency is limited on engines that spend a great deal of time around idle and/or low load operation (e.g. urban transit buses). Under these conditions, the engine exhaust temperature will be much lower than from a comparable dedicated NG engine, since the engine will be deriving most of its energy from diesel fuel. In some circumstances the catalyst may not achieve or maintain its light-off temperature. This could further impact emissions in a negative manner since most of the HC's will be diesel derived NMHC's.

Comparative results from two dual-fuelled engines are presented in Exhibit VII-10. The Caterpillar engine utilized an electronic control system originally developed by B.C. Research for the Canadian Gas Association (CGA). The controller was designed such that the quantity of natural gas was increased from 0% at idle up to 90% (energy basis) at rated load.

Emissions results in Exhibit VII-10, based on tests conducted over the U.S. FTP test procedure, confirm the impact of diesel fuel on overall emissions. Both engines suffer from a rise in HC and CO emissions compared with their all-diesel counterpart. This increase is partially attributable to incomplete combustion. It should be noted that NMHC emissions for the Caterpillar engine were only about 5% of the total hydrocarbons.

Pilot injection still requires development work if it is to become a viable low emissions approach. Ultimately, a pilot injection engine may still require a catalyst if it is to meet U.S. 1994 emissions regulations.

Stoichiometric Combustion

A large number of heavy duty gasoline engines have been converted to use natural gas. These conversions typically use a mechanically actuated venturi (for air-fuel mixing, open loop control systems (i.e. no feedback to the mixture controller) and no exhaust after treatment. These engines were converted because of the potential fuel economy advantages offered.

**Exhibit VII-10. Emissions from Diesel-Pilot Ignited
Natural Gas Engines^{49,50}**

	Fuel	Rating HP/RPM	HC(1)	CO [units: g/bhp-hr]	NOx	PM	Form
Caterpillar 3406	Diesel	350/1800	0.29	2.82	5.67	0.35	0.025
	Diesel/ Nat. Gas	350/1800	39.41 (2.13)	14.88	5.31	0.75	1.19
Cummins L10 Engine	Diesel	NR	0.46	2.14	13.40	0.54	NR
	Diesel/ Nat. Gas	NR	21.45	16.89	8.04	0.34	NR

Notes: (1) Bracketed figure represents non-methane HC.
NR denotes not reported.

49 Waldman, D.J. (Caterpillar Inc.); "Heavy Duty Liquid and Gaseous Fuel Emissions Database Test Results from Four Alternative Fuel Configurations of the Caterpillar 3406 Engine." Report prepared for U.S. DOE under contract number DE-AC05-84OR21400. June 1990.

50 Weaver, C.S.; - op cit.

Exhibit VII-11. Emissions from Stoichiometric Natural Gas Powered Heavy Duty Engines^{51,52,53,54}

Description	THC	NMHC	Form	CO [units: g/bhp-hr]	NO _x	PM
Engine type: GMC 454 in ³ IMPCO-open loop, no catalyst with 3 way catalyst	3.6 1.03	0.82 0.15	0.03 <0.01	31.9 10.8	6.6 1.33	0.01 0.01
IMPCO-closed loop, no catalyst with 3 way catalyst	3.73 1.41	0.85 0.22	0.03 <0.01	25.25 7.12	7.12 3.34	<0.01 0.01
TNO-closed loop, no catalyst with 3 catalyst	3.57 1.01	0.83 0.17	0.02 <0.01	23.29 6.64	6.87 1.16	0.01 0.01
Optimized engine forecast, with 3 way catalyst	0.66	0.09	<0.01	7.4	0.79	0.01
Saab-Scania 11L	1.10	NR	NR	1.01	1.84	0.01
Iveco 9.5L; closed loop, 3 way catalyst	0.8*	NR	NR	0.2	1.0	0.05

Notes:

- * Projects based on 8 mode test.
- NR denotes not reported.

- 51 Baines, T.M. (U.S. EPA); "Emission Characteristics of a GM 454 CID Engine Converted for Natural Gas Operation." Proceedings from the 4th Windsor Workshop on Alternative Fuels. June, 1988.
- 52 United States Environmental Protection Agency; "Analysis of the Economic and Environmental Effects of Compressed Natural Gas as a Vehicle Fuel - Heavy Duty Vehicles. Volume 2." Special report from the Office of Mobile Sources (no report number). April 1990.
- 53 Meinrad Signer, Iveco Motorenforshung AG; "Iveco Low Emission CNG Engine for Transit Bus". Proceeding from the Windsor Workshop on Alternative Fuels, June 1991.
- 54 "Co-Nordic Natural Gas Bus Project - Project No. 1, Motives, Execution, Results and Conclusions." June 1991.

There have been a few notable attempts to develop an optimized stoichiometric engine. During the late 1980's, the U.S. EPA conducted tests on a gasoline engine converted for use on natural gas. The engine, a turbocharged 7.4 litre (454 in³) Chevrolet V8, was retrofitted with increased compression ratio pistons and a turbocharger. This is one of the few instances where different control systems and catalyst efficiency were evaluated on the same engine. The results, in Exhibit VII-11, provide insight into the status of stoichiometric engines incorporating emissions control. With the exception of the THC results from the IMPCO closed loop system, all three engines meet the U.S.A. 1994 diesel bus standard. Both NO_x and particulate emissions were well within the 5.0 and 0.1 g/bhp-hr envelope for all three engines. A large measure of the reduction in regulated emissions can be attributed to catalyst efficiency. Overall, the converter gave reductions of 62-72% for total HCs, 74 - 80% for NMHCs, 72% for CO and 53-80% for NO_x. No explanation is available for the reason that the IMPCO open loop system produced lower HC and NO_x results than the closed loop controller. As emissions become more of a concern, it would appear more likely that closed loop systems will become the favoured route. The optimized engine performance forecast represents an EPA engineering estimate of the emissions potential from a stoichiometric engine based on the GMC 7.4 litre engine.

Work was carried out at Ricardo Laboratories in the U.K. for the Co-Nordic Natural Gas Bus Project to optimize a Saab-Scania 11 litre engine on natural gas. The Saab-Scania design employs a closed loop system with a three way catalyst and exhaust gas recirculation. Results to date have been encouraging. In its current configuration, the engine meets the U.S. 1994 heavy duty diesel emissions standards. As shown in Exhibit VII-11, both NO_x and particulates are reduced to 1.84 and 0.01 g/bhp-hr, well within the 5.0 and 0.1 g/bhp-hr standards. In addition, CO emissions are down to 1.01 g/bhp-hr; well within the standards.

Exhibit VII-12 summarizes some results of engines tested according to the European ECE R49 standard. Both the Caterpillar and Valmet engines, which employ catalysts, are well within the 1996 European standards. The results of the ECE R49 test are not directly comparable to U.S. FTP results. However, both engines do show relatively low THC results.

Lean Burn

Diesel engines readily lend themselves to conversion to lean burn systems. Lean burn operation enables a significant reduction in engine out NO_x without the need for a catalyst. Emissions data from two typical North American diesel engines for heavy duty vehicles are presented in Exhibit VII-13, along with preliminary results from a Volvo engine. The natural gas version of the Caterpillar engine was originally designed for constant speed

electrical generation. It was modified to accommodate variable speeds and loads, characteristic of truck operation. The data from the Cummins engine represents an open chamber design being developed for use in transit bus operations. Cummins has announced that it intends to sell a natural gas version of the L10 engine in 1993, certified to U.S. transit bus standards. Already, over 40 prototypes of this engine are in service across North America. The Volvo engine incorporates a modified combustion chamber. Emission optimization work is being performed by Southwest Research Institute as part of the Co-Nordic Natural Gas Bus Project. Volvo will deliver the first batch of 20 buses to Goteborg Transit in 1992. All engines are lean burn, built and optimized by the Norwegian Marintek company.

Exhibit VII-12. Emissions From Stoichiometric Natural Gas Powered Heavy Duty Engines Tested Over ECE R49⁵⁵

Description	THC	CO [units: g/kWh]	NO _x
Valmet 7.4L (Kemiras TWC)	0.1	0.1	0.4
Caterpillar 3306 (Englehard TWC)	0.12	0.41	0.51
Europe 1996	1.1	4.0	7.0

The results from the Cummins engine satisfy the 1994 U.S. emissions rules when equipped with a catalyst. No non-catalyst emissions data is available to determine overall catalyst efficiency. Based on a comparison with the 1990 diesel version of the engine, the natural gas version achieved a 92% reduction in CO and 86% in particulate. NO_x emissions were reduced by 10%, to 4.5 g/bhp-hr and are now within the 5.0 g/bhp-hr envelope. Although HC emissions rose compared with the diesel, as in the case of all natural gas engines, they primarily consisted of methane.

Emissions results from the Volvo engine were performed over the ECE R49 tests. These results are not directly comparable to the Cummins or Caterpillar results which were derived over the U.S. FTP cycle. The NO_x and CO emissions, at 2.22 and 0.16 g/bhp-hr are well within the 1996 European standards of 5.2 and 3.0 g/bhp-hr. Hydrocarbons, at 0.83

⁵⁵ EcoTraffic, Stockholm, Sweden 1991.

Exhibit VII-13. Emissions from Lean Burn Natural Gas Engines

	THC	NMHC	Emissions (g/bhp-hr) Form	CO	NO _x	PM	Test Cycle
Cummins L10 Diesel	0.48	0.46	NR	2.5	5.01	0.37	U.S. FTP
Cummins L10 Natural Gas W/Impco open loop and catalyst	1.3	NR	NR	0.2	4.5	0.05	U.S. FTP
Caterpillar 3406 SITA W/Impco open loop	9.1	0.74	0.34	3.2	4.1	0.6	U.S. FTP
Volvo 102KF*	2.2	0.4	NR	0.3	1.6	0.05	ECE R49

Notes:

- (1) NR denotes not reported.
- (2) Cummins L10 diesel represents typical 1990 diesel performance.
* Denotes converted from units of g/KWh to g/bhp-hr.

g/bhp-hr, are just outside the standard of 0.82 g/bhp-hr. Although no comparison between the U.S. and European test procedures exists, one can infer trends between cycles. NO_x emissions should not drastically change from the ECE R49 test values if the engines were tested over the U.S. FTP cycle, whilst THC values would be expected to rise. THC may pose a challenge for U.S. compliance.

Data from the Caterpillar engine in Exhibit VII-13 shows that all regulated emissions, with the exception of NO_x , increased compared to the diesel baseline case. The increases in particulate matter and HC emissions were primarily attributed to lube oil combustion. Over 95% of the particulate emissions was attributed to combustion of lubricating oil, which is a typical figure for natural gas operation. Oil would be drawn into the combustion chamber during idle and light load operation when engine vacuum is at its highest, due to the throttle plate of the gas induction system. Similarly, most of the HC emissions from the engine could be attributed to unburned methane. There is reason to expect that the use of a catalyst and improved low speed oil control should result in a marked improvement in regulated emissions.

The results from the Caterpillar engine indicate the need for lube oil control, especially with "clean fuels". Without proper attention, emissions due to lube oil consumption can easily over shadow the benefits gained from a switch in fuel type. The NO_x emissions from either engine are probably close to their lower limit based on lean burn operation. Future performance and efficiency improvements will likely create upward pressure on NO_x levels.

F. POTENTIAL EXHAUST EMISSIONS WITH FUTURE TECHNOLOGY

Preliminary data from tests conducted on optimized natural gas engines are quite encouraging. A natural gas engine could be optimized via increased compression ratio, advanced spark timing, combustion chamber configuration, exhaust gas recirculation (EGR), etc. Exhaust catalysts will also become necessary in the future. Exhaust gas recirculation can be used to lower engine out NO_x levels. Stoichiometric engines operating with EGR, as well as lean burn engines, will require the use of an efficient combustion chamber. In order to obtain a uniform air/fuel mixture the injectors, venturi and mixing units need to be investigated and optimized compared with today's best designs. A three-way catalyst can be used to reduce emissions in a stoichiometric engine, and an oxidizing catalyst can be used in a lean burn engine.

There is still debate on the merits of a stoichiometric versus a lean burn approach. Proponents point to the relative merits of either approach, the key

ones being three-way catalytic treatment for stoichiometric operation versus reduced engine out NO_x and lower fuel consumption with lean burn. Both approaches will require a reduction in total hydrocarbon emissions. Conventional catalyst technology relies on oxidizing reactive HC's and is relatively ineffective against the stable methane molecule. Catalyst manufacturers have only recently begun to seriously examine formulations that can oxidize methane emissions.⁵⁶ Johnson Matthey and Finnish Kemira have R&D results that show substantial improvement.⁵⁷ Unfortunately no data is available at this time.

CO and NO_x control should not pose a problem. Catalyst technology from automotive gasoline engines can be applied to natural gas powered vehicles. Catalyst CO and NO_x conversion efficiencies on natural gas powered vehicles should be comparable to those obtained on gasoline vehicles, provided the air fuel ratio metering precision approaches that on a gasoline engine.⁵⁸

In the case of three-way catalysts, some of the barriers that catalyst manufacturers face include selecting a relatively low cost noble metal that will oxidize methane emissions and yet also provide a NO_x reduction. Without a sufficient quantity of reactive hydrocarbons, such as olefins, aromatics, and long chain paraffins, NO_x reduction in a three-way catalyst may be limited. Alternatively, the engine may have to be run richer than required in a typical gasoline engine to promote NO_x reduction.⁵⁹

Both palladium and rhodium have been identified as potential catalysts for methane.⁶⁰ Rhodium also offers the advantage of being very active for converting ethane and propane, as well as being effective at reducing NO_x under stoichiometric conditions. It is currently used on three-way catalysts for gasoline engines.

Catalyst efficiency is also dependent on catalyst operating temperature. Compared with other paraffin family hydrocarbons, methane requires much

⁵⁶ SYPHER:MUELLER International Inc. diary notes; SAE Methanol and Natural Gas Optimized Vehicle Workshop. Knoxville, Tenn. September 12-13, 1990.

⁵⁷ Co-Nordic Natural Gas Bus Project, 1991.

⁵⁸ Hundlby, G.E. (Ricardo Consulting Engineers Ltd.); "Low Emissions Approaches for Heavy-Duty Gas-Powered Urban Vehicles." SAE Paper 892134.

⁵⁹ Weaver, C.S. (Sierra Research); "Natural Gas Vehicle - A Review of the State of the Art." Report Prepared for Natural Gas Vehicle Coalition. Report No. SR89-04-01, April, 1989.

⁶⁰ Summer, J.C. et al (Allied Signal, Inc.) "Catalytic Control Issues Associated with the Use of Reformulated Gasoline." SAE paper 902072.

higher catalyst temperatures to be oxidized. Given that natural gas burns at a lower temperature than gasoline, natural gas exhaust can potentially be lower in temperature than gasoline engine exhaust. Hence catalyst location will become critical. The catalyst may have to be close coupled to the exhaust manifold in order to rapidly reach its light-off temperature. As more attention is focussed on the cold start portion of the emissions test, catalysts may require auxiliary heaters to initiate a catalytic reaction.

Catalyst performance has been known to deteriorate over time, based on experience from the Co-Nordic Natural Gas Bus Project. Natural gas carries few, if any, of the impurities found in gasoline that could poison a catalyst. However long-term catalyst durability has yet to be proven.

To reduce NO_x emissions during stoichiometric operation even further, Exhaust Gas Recirculation (EGR) can be used. With EGR, a portion of the exhaust is recirculated into the combustion chamber along with the new fuel air mixture. Typically some 2 to 15 percent of the total air-fuel mixture can be replaced this way.

The exhaust gas is inert and therefore does not influence the stoichiometric values of the air-fuel mixture. As EGR dilutes the fuel, this technology takes advantages of properties offered by both stoichiometric and lean burn engines. The inert exhaust gas absorbs heat, helping to reduce NO_x . The 11 litre Scania engine, described under the stoichiometric engine section can utilize up to 15% EGR to reduce emissions.

Diluting with EGR requires an effective combustion process to prevent high HC discharges from incomplete combustion. The use of EGR will also entail a loss in rated power compared with a naturally aspirated engine. The EGR will displace combustible mixture. Fortunately, naturally aspirated engines are not widely used in the countries that are pushing for very low emissions.

Air fuel metering precision will also be essential in order to optimize catalyst conversion efficiency. The lambda window, i.e., the available air-fuel ratio where a catalyst can be effective on HC, CO and NO_x , is much narrower for natural gas. It is therefore, necessary to perfect a natural gas control system that operates within this window. The latest technology in this field is the so called "adaptive" system, whereby a computerized control system can learn from engine behaviour and thereby optimize itself after some time in operation.⁶¹ Feedback signals from ordinary closed loop systems with sensors have a built-in lag time attributed to the distance between a fuel injector and a lambda sensor in the exhaust system. Feedback to the fuel injector is based on past events, therefore the system is always trying to correct for historical events. An adaptive control system can take future

⁶¹ Ekelund, M, et al. (EcoTraffic); Co-Nordic Bus Project, 1991.

effects into account and compensate for acceleration and deceleration when needed. Feedback sensors on an adaptive system would serve as a redundant link and validate optimal engine operation.

G. EVAPORATIVE AND REFUELLING EMISSIONS

Evaporative emissions consist of fugitive releases of unburned fuel from the vehicle fuel system during vehicle operation (running losses) as well as when the vehicle is parked (hot soak and diurnal losses). Evaporative emissions are a function of fuel volatility and vehicle fuel system design. Dedicated natural gas vehicles should have not evaporative emissions because of closed fuelling systems. Bi-fuel vehicles will still have some evaporative emissions due to gasoline stored on the vehicle.

Refuelling emissions occur while a vehicle is fuelled. Fuel vapour can escape from the fuel nozzle-vehicle port connection into the atmosphere. Similar to evaporative emissions, refuelling emissions are a function of fuel volatility and fuel nozzle-vehicle port design.

Evaporative and refuelling emissions from gasoline powered vehicles have been a growing concern in North America, Europe and Japan. Recently, both the U.S. and California have promulgated more stringent evaporative emissions test procedures. These new regulations would in effect, eliminate evaporative emissions.

Natural gas primarily consists of methane. Hence, reactive or NMHC evaporative or refuelling emissions from natural gas vehicles are by nature low. Furthermore, evaporative emissions from a natural gas vehicle are minimized because of the fuel system design. Both compressed and liquefied natural gas use closed fuel systems.

Except for the release of small volumes occurring between the refuelling probe and the receiving valve on the vehicle during refuelling, dedicated natural gas vehicles should not have any NMHC evaporative or refuelling emissions. Bi-fuel (gasoline-natural gas vehicles) should experience a reduction in the quantity of NMHC emissions attributable to refuelling. The reduction could be estimated to be proportional to the ratio of gasoline to natural gas use.

H. EMISSIONS DURING FUEL EXTRACTION, PROCESSING AND DISTRIBUTION

Tailpipe exhaust emissions are not the only source of motor vehicle emissions. There are several activities associated with natural gas extraction,

preparation and delivery that also contribute to emissions. These activities, summarized in Exhibit VII-14, comprise the fuel cycle.

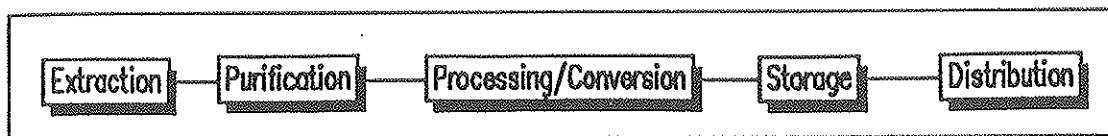

Exhibit VII-14. Fuel Cycle

The fuel cycle for natural gas is relatively uncomplicated. Gas that is extracted from a well must be sweetened to remove its sulphur content. The processes that require energy and hence, create emissions, include extraction, processing, distribution and end delivery.

The overall efficiency for the natural gas fuel cycle is estimated between 78% and 89%^{62,63} and varies depending on, for example, the need for purification, distribution compressor capacity and intake pressure to the end user compressor. Approximately 11 to 22% of the energy content of natural gas is expended before natural gas can be delivered to an end user. These activities will give rise to emissions. Exhibit VII-15 gives a cursory breakdown of the energy efficiency at different stages in the fuel cycle.

Exhibit VII-15. Efficiency For a Natural Gas Fuel Cycle⁶⁴

Process	Efficiency in %
Extraction/gathering	96-97.5
Preparation/processing	96.8-97.5
Storage	99.6
Transport	95 - 97
Dispensing	88.4 - 97.3
Total	78 - 89

⁶² "Fuel: From Source to End Use" (Swedish) Stage 1, Prestudy; M. Ekelund; Vattenfall, U(G) 1990/63.

⁶³ "Comparing The Impacts Of Different Transportation Fuels On The Greenhouse Effect;" Aurex Corp., California Energy Commission, 1989.

⁶⁴ "Natural Gas Vehicles And The Greenhouse Effect;" Daniel Sperling; First Annual Natural Gas Vehicle Conference, Oct. 28 - 30, 1988, Sydney, Paper 41.

The major emissions sources in the natural gas fuel cycle include the gas sweetening process as well as emissions during gas distribution. Exhibit VII-16 summarizes emissions over the natural gas fuel cycle on a per cubic metre of gas processed basis. The bulk of SO_x emissions occur during the gas sweetening process when sulphur is released from the sour gas. The HC, CO and NO_x emissions primarily occur during the distribution phase. Compressors must be used to move the gas from the field through the pipeline and into vehicle storage cylinders.

Exhibit VII-16. Emissions During the Natural Gas Fuel Cycle(g/m³)⁶⁵

SO _x	CO	HC	NO _x	CO ₂
0.1670	0.097	0.014	0.235	104.1

I. GREENHOUSE GAS EMISSIONS

About 90% of incoming solar energy is absorbed by the atmosphere, oceans and land mass of the Earth. Much of this energy is then reradiated by the Earth. Greenhouse gases trap a portion of this energy to keep our planet at an inhabitable temperature. Without the warming (greenhouse) effect, the average temperature on earth would be -20°C.⁶⁶ Concern over greenhouse gases emanates from the hypothesis that human activity, particularly over the last century, has increased the greenhouse gas concentration in the atmosphere which will lead to (or already has begun) global warming. Many models predict a 1.5 to 4.5°C increase in global temperature due to a doubling of ambient CO₂ levels from pre-industrial levels.⁶⁷

Greenhouse gases include carbon dioxide (CO₂), methane (CH₄), ozone (O₃), nitrous oxide (N₂O), chlorofluorocarbons (CFC's) and water vapour (H₂O). Carbon dioxide is the principle product resulting from combustion of

⁶⁵ "Cost Effectiveness of Alternative Transportation Fuels in Urban Bus Operations". Report prepared for Efficiency and Alternative Energy Technology Branch, Energy Mines & Resources Canada by SYPHER:MUELLER International Inc. November 1989.

⁶⁶ Amann C.A. (General Motors Research Laboratories); "The Passenger Car and the Greenhouse Effect". SAE Paper 902099.

⁶⁷ U.S. Congress, Office of Technology Assessment; "Changing by Degrees: Steps to Reduce Greenhouse Gases" OTA-0-482 (Washington, D.C.: U.S. Government Printing Office) February 1991.

a carbon containing substance and is typically identified as the principle greenhouse gas.

Although the other greenhouse gases are produced in smaller amounts than carbon dioxide, they do have higher global warming potential per gram. The warming potential for a specific gas depends on its capacity to absorb energy and its residency time in the atmosphere. Exhibit VII-17 summarizes the global warming potential of CO₂, CH₄, and N₂O. It should be noted that there are many uncertainties associated with the indices in the exhibit.

Exhibit VII-17. Relative Global Warming Potential (GWP)

Gas	Global Warming Potential ⁶⁸ (per gram CO ₂)	Range ⁶⁹
CO ₂	1	1
CH ₄	11	+/-75%
N ₂ O	270	+/-25%

When determining warming potential, the effects of O₃, H₂O, and CFC emissions are typically neglected. Fugitive CFC emissions from motor vehicle air conditioning systems are assumed to be independent of fuel type. Although water vapour can absorb both solar and thermal radiation, cloud cover can also reflect solar radiation. Therefore the overall climatic effect of water vapour is still uncertain. Furthermore, the release of water vapour during the combustion of fossil fuels is thought to constitute a negligible portion of the water in the atmosphere.⁷⁰ Tropospheric ozone is the result of reactive HC's, NO_x, and photochemical radiation. Researchers are still uncertain as to its treatment when considering greenhouse effects. It should be pointed out that N₂O is not a product of combustion. Rather, it is a result of catalytic reduction of NO_x.

68 Environment Canada; "Canada's Greenhouse Gas Emissions Estimates For 1990". Draft, April 1992.

69 "Comparing the Impacts of Different Transportation Fuels on the Greenhouse Effect" Report prepared for California Energy Commission" by Accurex Corp. April 1989.

70 Deluchi, M.A. et al; op. cit.

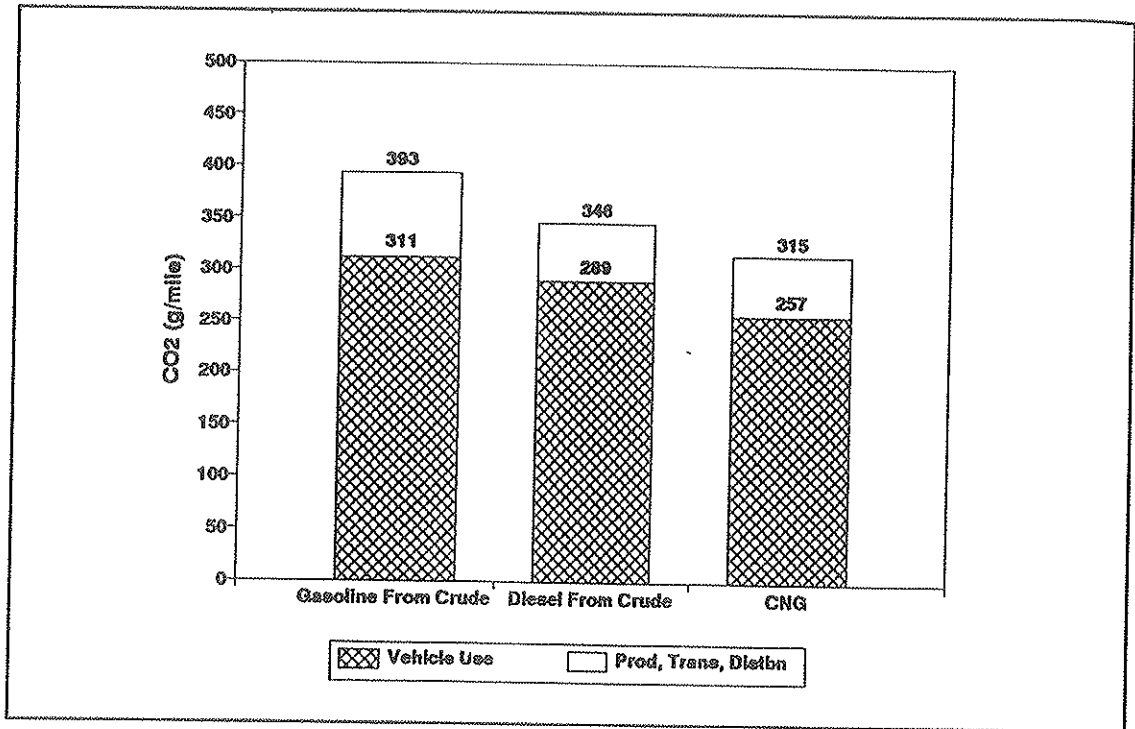

Exhibit VII-18. Summary of CO₂ Production For The Fuel Cycle

When examining the greenhouse effect of transportation fuels it is important to account for all the principal greenhouse gases from fuel extraction through to combustion in the vehicle. As shown in Exhibit VII-18, compressed natural gas in vehicles produces the lowest carbon dioxide emissions compared with diesel and gasoline in similar situations. However, the exhibit does not include the global warming potential of methane and nitrous oxide. When the full effect of these gases is included, as in Exhibit VII-19, then the benefit of reduced CO₂ is somewhat offset by CH₄ and N₂O; providing some advantage relative to gasoline, but no distinct advantage over diesel. Again it should be noted that the range of estimates and scientific uncertainty do not allow definite conclusions. More scientific and engineering studies are required.

The preceding analysis illustrates that any decrease in greenhouse gas emissions must be tied to a change in fuel type and improved vehicle efficiency. Short of a conversion to hydrogen fuel or non-fossil fuel derived electric power, natural gas offers opportunity to reduce greenhouse gas emissions relative to gasoline. It provides the lowest overall CO₂ emissions. However, an accounting of all greenhouse gas emissions is required. Although natural gas has a lower overall warming potential than gasoline, it does not have a clear advantage over diesel fuel due to methane emissions.

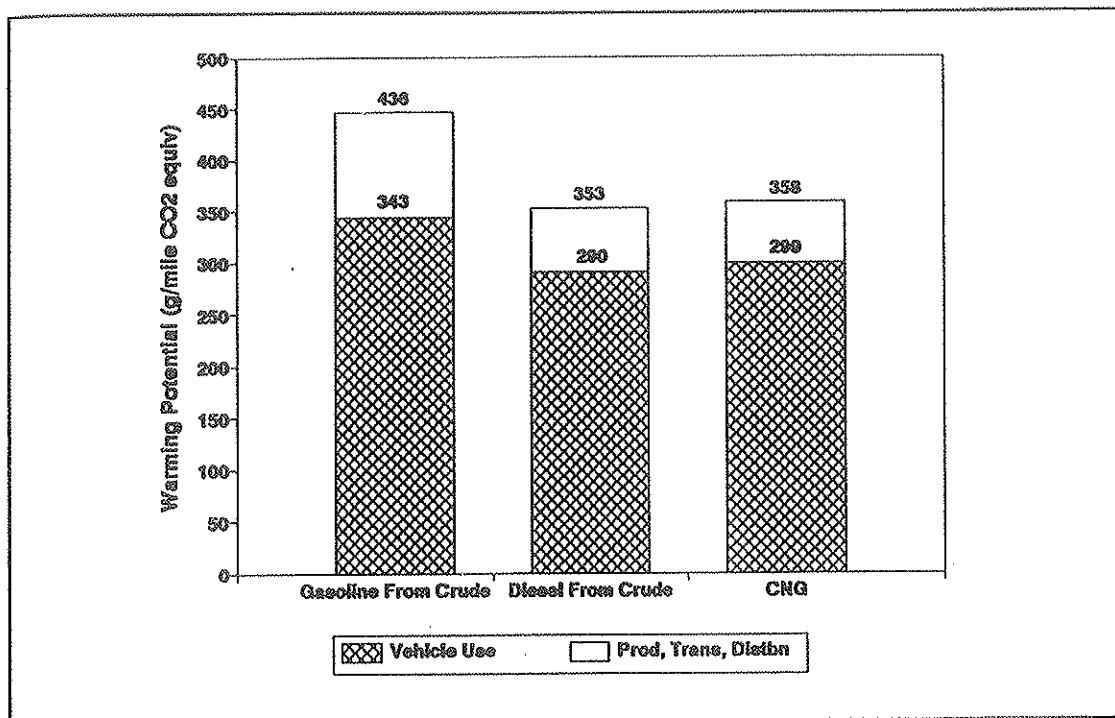

Exhibit VII-19. Warming Potential For The Fuel Cycle

J. BIOGAS EMISSIONS

The fuel cycle for biogas is generally restricted to a local system, thus minimizing the requirement for an extensive distribution system. Biogas is produced using locally produced biomass. The fuel cycle and fuel cycle emissions will be dependent on the feedstock used to produce the gas, for example, municipal sewage plant, waste plant or crops. The resultant biogas mixture (CH_4 , CO_2 and H_2S) must be processed before it can be used in motor vehicles.

The energy efficiency, an indicator of CO_2 emissions over the natural gas cycle is 66 to 73% of the energy content of biogas (Exhibit VII-20). This estimate excludes the energy loss for storage at 99.6% efficiency. Other sources of emissions during the fuel cycle, not reported here, include the emissions expenditure for feedstock collection and delivery to the digester. In the case of crop material, this can include emissions to plant, cultivate and harvest the feedstock. However, in the case of biogas produced from crop material, CO_2 production during the fuel cycle should be offset by CO_2 uptake during plant growth.

Once biogas has been processed (i.e. impurities and CO_2 removed), biogas should not differ from conventional sources of processed natural gas. As such, vehicle emissions should not be any different than conventional sources of natural gas.

Exhibit VII-20. Efficiency for the Biogas Fuel Cycle

Process	Efficiency in %
Energy Demand Digester Process	80 - 85%
Cleaning and Dispensing	90%
Losses to Leakage etc.	90 - 95%
Total	66 - 73%

K. NOISE

There are three primary sources of motor vehicle noise; motor, exhaust pipe and tires. Tire noise can be characterized as high frequency and generally is the dominant noise from heavy vehicles at speeds over 50 km/hr. When comparing natural gas powered vehicles to either gasoline or diesel fuelled vehicles, noise characterization and noise reduction potential will be of greater interest to the heavy duty market which primarily consists of diesel engines. Engine noise tends to be much greater from diesel compared with gasoline or Otto cycle engines.

Methane gas as a heavy duty engine fuel can lower engine noise level. One source estimates 10dB noise reduction.⁷¹ This reduction can be attributable to a reduction in compression ratio and altering from a diesel cycle to an Otto cycle.

Some noise measurements were reported from a Hino bus tested with diesel and natural gas while on a chassis dynamometer. The results, reported in Exhibit VII-21, show that the measured sound level was reduced with natural gas irrespective of vehicle speed. Depending on measurement location in the bus, noise levels dropped from 1 to 7 dBA with natural gas. Roadside noise levels were also reduced. The authors reported roadside noise levels of 83.5 dBA for the natural gas bus versus 88.5 dBA for diesel.

There have also been qualitative assessments on noise levels from natural gas vehicles. However, much of this qualitative data reporting on noise must be viewed very critically. There has been a general perception by drivers that natural gas powered engines produce less power than their diesel or gasoline counterparts. Hence, some drivers draw the conclusion that engine noise on natural gas is therefore reduced. However, before any definite conclusion

⁷¹ "Natural Gas as a Piston Engine Fuel" (Swedish); M. Ekelund, R. Egnell, R. Gabrielsson; STU information, No. 751. 1989.

can be reached, further noise measurements must be carried out to quantify noise levels from equally rated natural gas and conventional fuel engines under identical driving conditions. Testing should encompass the entire range of possible engine designs. This includes bi-fuel while on natural gas versus gasoline as well as unmodified gasoline; dedicated natural gas; and dual-fuel.

Exhibit VII-21. Summary of Interior Noise Levels for a Natural Gas Powered Vehicle⁷²

Engine Speed RPM	Vehicle Speed KM/H	Sound Level (dBA)		
		Front	Middle	Rear
1500	45	70 (75)	71 (73)	72 (73)
2500	78	76 (82)	78 (80)	77 (77)
3000	90	78 (85)	81 (82)	80 (82)

Bracketed "()" figures are for diesel fuelled vehicle.

L. SUMMARY

Natural gas powered vehicles have been the subject of intense interest recently. This has been driven in part by regulatory pressures in the U.S. and the State of California. Regulatory authorities in both jurisdictions have drafted much more stringent emissions regulations for the mid 1990's. California rules, which are the most far reaching, would apply to all fuels and seeks to limit emissions based on photo chemical reactivity. With the exception of California, most jurisdictions have focussed on mass limiting rules specific to gasoline and diesel.

Exhibit VII-22 presents an overall summary of the potential advantages of natural gas in motor vehicles relative to current gasoline and diesel technology.

⁷² Raine, R.R. et al; "Report on the Conversion of Diesel Engines to CNG Spark Ignition Operation". New Zealand Liquid Fuels Trust Board, Project No. 640/10/1. Wellington.

Exhibit VII-22. Summary of Emissions Benefits With NGV's

Engine/Technology	NMHC	CO	NOx	Particulates	CO ₂	Air Toxics	Remarks
Light Duty: Bi - Fuel (relative to gasoline)	+	+	-	NR	+	+	CO emissions can pose a problem if the fuel system is improperly calibrated; NOx are also dependent on calibration.
Light Duty: Dedicated & Optimized (relative to gasoline)	++	++	+/-	NR	+	++	NOx reductions are possible, however, further development work is required.
Heavy Duty: (relative to diesel)	++	++	++	++	+	++	Active R&D is underway, initial results look very promising.
Evaporative & Refuelling: Dedicated (relative to gasoline)	++	NR	NR	NR	NR	++	Eliminates escapes of NMHC.
<p>Key:</p> <ul style="list-style-type: none"> + some improvement (<30%) in emissions relative to gasoline or diesel fuel. ++ significant improvement (>30%) in emissions relative to gasoline or diesel fuel. - some deterioration (<30%) in emissions relative to gasoline or diesel fuel. NR not relevant. 							

Bi-fuel conversions produce lower non-methane hydrocarbons which will lower ozone formation. Air toxics should also be lowered. Carbon monoxide should also be lower but is somewhat dependent on engine calibration. A poorly tuned engine could produce higher levels of nitrogen oxides or carbon monoxide.

Dedicated natural gas powered vehicles hold the greatest promise for reduced emissions. These engines will include improvements in combustion efficiency, air-fuel metering capabilities and catalyst efficiency.

Compared with gasoline, natural gas has the inherent advantage of using a sealed fuel system which should minimize fuel system escapes during vehicle operation, while parked and refuelling. Any fuel escapes that do occur will primarily be limited to methane, a non-reactive hydrocarbon.

Tailpipe exhaust and evaporative emissions are not the only source of motor vehicle emissions. Emissions can occur over the entire fuel cycle which consists of resource extraction; purification; processing/conversion; storage; and distribution. Since the natural gas fuel cycle is relatively uncomplicated, it is estimated that the overall fuel cycle efficiency is between 78 to 89% efficient. Approximately 11 to 22% of the energy content of the gas is lost over the fuel cycle. The major emissions constituent over the fuel cycle is carbon dioxide. Biogas derived fuel has a lower fuel cycle efficiency than conventional natural gas sources. The efficiency loss arises primarily due to the energy demand during the digestion process, cleansing process and losses due to leakage in the digestion system.

Overall, natural gas powered vehicles produce less carbon dioxide emissions than either gasoline or diesel vehicles. However, there is some uncertainty with respect to the impact of methane on the overall warming potential.

Natural gas has the potential to reduce engine noise levels in heavy duty engines. The reduction can be attributable to a reduction in compression ratio and altering from a diesel cycle to an Otto cycle.

VIII HEALTH AND SAFETY CONSIDERATIONS

A. HEALTH AND SAFETY OVERVIEW

This section examines the impacts of natural gas as a motor vehicle fuel on human health and safety. For illustrative purposes, fuel properties are compared with those of diesel and gasoline. Exhibit VIII-1 compares selected physical and chemical properties of natural gas to gasoline and diesel.

From a safety perspective there are two major concerns when considering a new fuel; flammability and toxicity.

Flammability

Natural gas has a vapour specific weight (weight with respect to air = 1) of 0.6 and a diffusion coefficient of 0.16 cm/s, over three times that of gasoline. Therefore any release of natural gas will tend to rapidly rise and disperse into the atmosphere.

A fire or explosion requires both fuel and an ignition source.

Natural gas has a wider flammability range than either gasoline or diesel. Its flammability limits range between 5% to 15% in air versus 1.4% to 7.6% and 0.6% to 5.5% for gasoline and diesel, respectively. While natural gas has a wider flammability range than gasoline, its lower flammability concentration is four times that of gasoline. Natural gas also requires a slightly greater amount of energy, measured as spark ignition energy, to ignite the fuel. Similarly, its auto ignition temperature, at 540°C, is much higher than either that of gasoline or diesel, at 220 and 225°C respectively.

A gas release into a well ventilated area, either indoors or outdoors, should not pose a problem. Under these conditions the fuel will rapidly disperse. Flammable concentrations would not be expected, except near the vapour source or leak, and pockets near the ceiling, given the propensity of natural gas to rise as it disperses.

Exhibit VIII-1. Selected Physical and Chemical Properties of Natural Gas, Gasoline and Diesel

	Natural Gas	Unleaded Gasoline	Diesel Fuel
Physical Properties:			
Chemical Formula	85-95% CH ₄	C ₄ -C ₁₂	C ₁₄ -C ₁₉
Appearance	Colorless gas	Clear-amber liquid	Amber liquid
Boiling point, C	-162	27-210	188-340
Fuel density, kg/l	CNG: 0.19 LNG: 0.42	0.73-0.75	0.81-0.88
Fuel vapor density	0.6	2-4	4-6
Reid vapor press, kPa	N.A. (gaseous)	50-100	0.1-1.5
Heat of vapor, kJ/kg	509	275-365	225-280
Electrical Cond., US/m	N.A. (gaseous)	0.000001	0.0001
Vapour diffusion coefficient, cm/s	0.16	0.05	not available
LHV, kJ/kg	43,520	43,800	42,800
LHV, kJ/L	CNG: 8910 LNG: 18,300	32,400	36,400
Flash point, C	N.A. (gaseous)	-43	58-116, Avg. 73
Autoignition temp., C	540	220	225
Spark ign. energy, mJ	0.29	0.24	0.24
Flammability Limits, %	5-15	1.4-7.6	0.6-5.5
Stoichiometric Air/Fuel	17.2	14.7	15.0
Flame visibility, rel.	0.6	1.0	1.0
Flame spread rate, m/s	N.A. (gas)	4-6	0.02-0.08
Flame temperature, C	1790	1977	2054

N.A. = Not applicable.

Source: "Clean Air Program: Alternative Fuel Data Summary." Prepared by Battelle Memorial Labs for the Urban Mass Transportation Administration. Publication number UMTA-OH-06-0056-90-3. March 1990.

A flammable or explosive mixture of natural gas is more likely to occur in a poorly ventilated area, such as a garage. For example, the 5 to 15% flammable concentration mixture window could occur if a vehicle fuel system leaked. Exhibit VIII-2 depicts the concentration of natural gas in a typical garage based on the mass of gas at standard temperature and pressure (stp). A leak of between 4.5 to 12.8kg would create a flammable concentration, assuming it was contained within the enclosure.

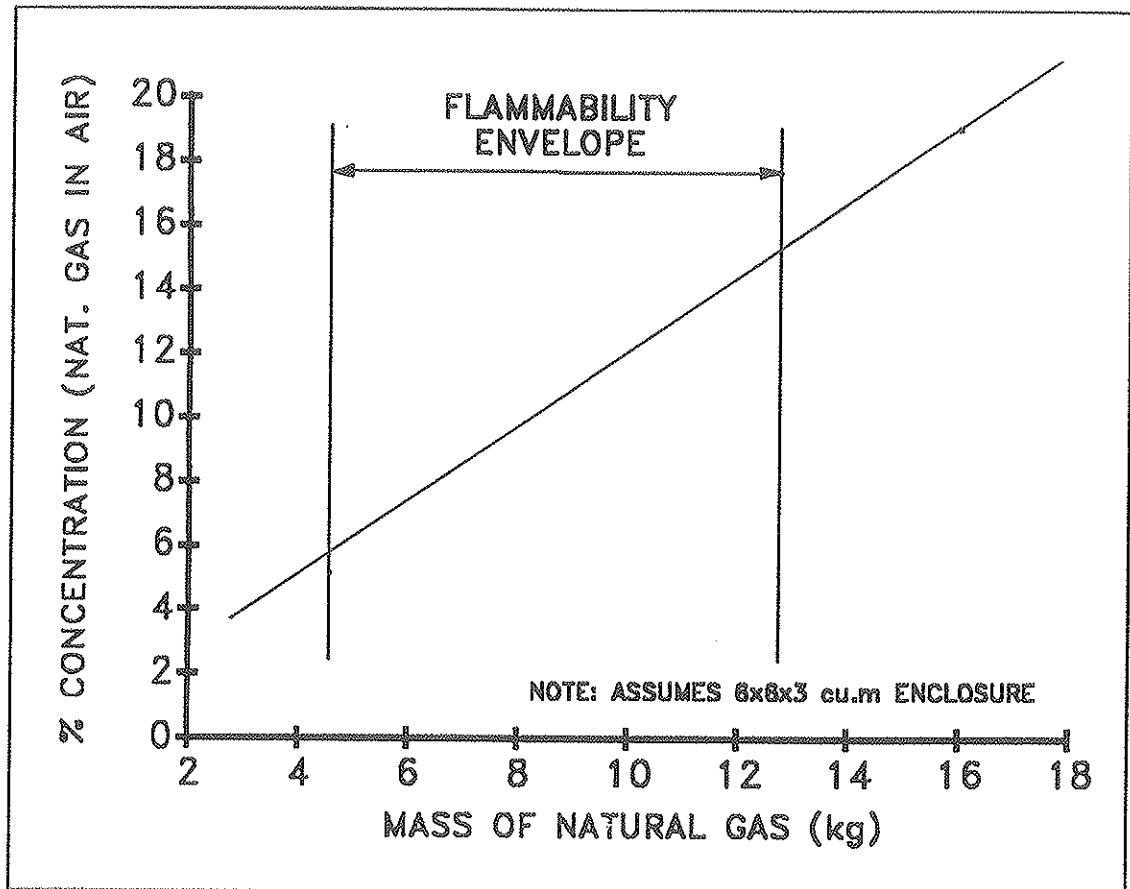

Exhibit VIII-2. Flammability Envelope of Natural Gas As a Function of Mass of Gas

A natural gas fire fed by a pressurized container would take a completely different form than a liquid fuel fire. Ignition of a gas stream would result in a torch flame at the site of the leak, with the rate of heat release governed by the rate of fuel release. On a weight basis, natural gas has a net energy content of 44 MJ/Kg which is equivalent to 1.34 litres of gasoline or 1.20 litres of diesel. Natural gas also burns with a lower flame temperature than either gasoline or diesel. Assuming that the flame was not in contact with any flammable material or the heat radiated was not sufficient to ignite any adjacent material, the fire would extinguish itself once the fuel source was consumed. This contrasts with the situation of a gasoline or diesel fuel fire

n a
5%
em
cal
p).
on,

which would most likely take the form of a pool fire. A liquid pool fire also burns with a defined heat release rate which is a function of the heat of combustion and rate of fuel combustion.

Overall, a study of safety issues related to CNG use concluded that diesel is safest, whilst CNG fuel is safer than gasoline due to the higher rate of dispersion of CNG and its lower flammability concentration limit.⁷³

Specific Risks With LNG

When fully vapourized, LNG exhibits the same properties as natural gas. However, the extremely low temperatures of LNG may reduce the normally high dispersion rate of methane and possibly create a combustible methane/air mixture that could spread beyond the spill area. But, LNG vapourizes quickly and mixes well with air. Thus, this risk applies to large spills but not to small leaks. The amount of LNG stored on a vehicle is relatively small. Furthermore, LNG is stored in double-walled tanks that are stronger than gasoline tanks.

Another factor is that it is not possible to eliminate heat transfer to the inner LNG tank completely. Therefore, some warming and pressure buildup will happen, requiring periodic venting of the natural gas. This means that a LNG vehicle stored for any period of time would have to be left outdoors or in a well ventilated area.

Because normal odourants used in natural gas should be removed in making LNG, there is no warning odour to indicate a LNG leak. The need for alternative odourants and methane detectors needs to be explored.

Refuelling of LNG should be done by trained personnel because of the danger of frostbite through contact with LNG or metal cooled by LNG.

Toxicity

Overall, natural gas is quite benign compared to either gasoline or diesel. Exhibit VIII-3 presents a comparative overview of toxicity ratings for gasoline and CNG.

⁷³ M.C. Krupka et al (Los Alamos National Laboratory); "Gaseous Fuel Safety Assessment for Light-Duty Automotive Vehicles." Prepared for the Department of Energy. Report No. LA-9829-MS. November 1983.

Exhibit VIII-3. Comparative Toxicity Ratings

Fuel	Eye Contact	Inhalation	Skin Penetration	Skin Irritation	Ingestion
Gasoline	2	3	3	1	2
Methane (CNG)	0	3*	0	0	NA

- Note: A. Scale; 1 = Mild, 5 = extreme toxicity
 B. Values for gasoline can vary depending on composition.
 C.* Natural gas is dangerous only to the extent that it displaces air and acts as an asphyxiant.

Source: J.V. Steare, ed.; "CRC Handbook of Laboratory Safety", 2nd edition. Boca Raton Fla. 1971.

There is no known carcinogenic risk due to either acute or prolonged exposure to natural gas. Similarly, natural gas is neither toxic or caustic. Natural gas only presents a concern with respect to inhalation. If the gas concentration is great enough, it can displace oxygen and act as an asphyxiant.

Conversely, both gasoline and diesel are in a liquid state at Standard Pressure and Temperature (STP). Either can enter the human system via inhalation, dermal contact or ingestion. Prolonged contact with gasoline can prove toxic since it can be absorbed through the skin.⁷⁴

Although natural gas itself will not cause skin irritation, severe frostbite can occur through contact with gas fittings when the gas rapidly expands to atmospheric pressure. Contact with LNG can also produce severe cases of frostbite.

B. SAFETY ISSUES - MOTOR VEHICLE OPERATION

Motor vehicle operation refers to vehicle refuelling, operation, storage and maintenance.

Although there is limited safety data available relating to in-fleet experience with natural gas, particularly with LNG vehicles, one can derive certain hypothesis concerning safety from a review of system components and existing data.

⁷⁴ Chemical Rubber Co.; "Handbook of Analytical Toxicology." 1975.

An often cited weakness with a natural gas fuelled vehicle is the use of a pressurized fuel storage container. However, there are stringent regulations covering the use of pressure vessels in many countries. These regulations are designed to ensure the mechanical integrity of pressure vessels under conditions of pressure and thermal cycling. Furthermore, extensive abuse testing has been carried out to demonstrate the structural integrity of pressurized containers. These tests have included crash, drop and fire tests far beyond what a fuel vessel would normally be exposed to over its life. The results of these tests indicate that the integrity of the fuel tank should not pose a problem. Rather, components such as the fuel lines, fittings, valves, etc. could limit overall system reliability.

The safety issues of concern, raised by the use of natural gas, as opposed to a conventional liquid motor vehicle fuel include:

- The overall integrity of the fuel lines, valves and fittings. The fuel system is more prone to leakage since it is constantly under pressure.^{75,76} Any line or fitting failure results in a fuel release.
- Mechanical limitations on the cylinder. The fuel tank is subject to an upper pressure limitation (maximum load) as well as repeated refillings (cyclic loadings). The fuel tank will have to be periodically inspected to ensure its mechanical integrity. Questions have been raised about the validity of a hydrostatic test to predict a cylinder failure.⁷⁷
- Concern over fuel system corrosion (steel tanks and fittings), insofar as it could result in a fuel release. Corrosion can occur as a result of both external and internal (moisture within the gas) sources. Corrosion will be of special concern in climates where under body mounted gas tanks will be exposed to road salt and exhaust heat.
- Weight, placement and anchoring of the fuel storage tanks, insofar as they could become a projectile in the event of an accident.

⁷⁵ Krupka, M.C. et al; *ibid*.

⁷⁶ U.S. E.P.A.; "Analysis of the Economic and Environmental Effects of Compressed Natural Gas as a Vehicle Fuel, Vol II, Heavy-Duty Vehicles." Special report, Office of Mobile Sources. April 1990.

⁷⁷ Dr. A. Akhtar (Powertech Labs) Comments made during presentation entitled "Safety Regulations and Fitness for Purpose Philosophy." NGV Safety Regulation Seminar. Toronto, Canada. June 27, 1991.

- Issue of disposal or salvage of gas cylinders from retired vehicles. Vehicle fuel cylinders will have a much longer design life than the vehicle on which they were initially installed.
- Cryogenic burns resulting from the rapid expansion of gas to atmospheric pressure.
- Method to handle boil off fuel from LNG fuel tanks, particularly during periods of vehicle inactivity.
- Vehicle refuelling, particularly at self serve stations.
- NGV conversions and aftermarket services. This move will be of special interest in countries where NGV aftermarket conversions become a "cottage" industry.

Most of the above are design related issues that are addressed in most cases through modifications to the vehicle fuel system and proper training.

Natural gas fuelled vehicles offer a number of safety advantages compared to conventional fuelled vehicles. These include:

- Compressed natural gas fuel tanks have been demonstrated to be nearly indestructible, and will more likely survive a vehicle crash or impact than a conventional fuel tank.
- A fuel tank explosion is less likely to occur with a CNG fuel cylinder compared with a conventional fuel tank. A CNG tank is designed to bleed off gas in the event of an internal over pressure. In the event of fuel ignition at the vent point, there will be a torch flame.
- Natural gas vehicles employ a closed fuel system which eliminates emissions during refuelling.

Limited in-use statistical data seems to indicate that natural gas vehicles are not any more dangerous than conventional fuel vehicles. Data from Italy and the U.S. indicates that there were no reported fuel cylinder failures attributable to vehicle collisions.^{78,79}

⁷⁸ Abram, R.N., et al; "Report of Overseas Visit to Investigate Compressed Natural Gas in Italy." Liquid Fuels Trust Board, N.Z. February 1980. (as reported in SAE 881656).

⁷⁹ Tison, R.R., et al; "Safety Issues Surrounding the Use and Operation of Compressed Natural gas Vehicles." Presented at the SAE specialty Conference -- Compressed Natural Gas as a Motor Vehicle Fuel, Pittsburgh, Pa. June 1983 (as reported in SAE 881656).

Operating experience in Italy⁸⁰ indicates that there were 0.0049 explosions per 1000 fuel cylinders (based on a population of approximately 0.75 million cylinders) between 1974 and 1980. No incidents were reported between 1981 and 1983. The repercussions of any on-board vehicle natural gas system failure can be extensive. An examination of an exploded steel fuel cylinder in New Zealand revealed that failure was caused by metal fatigue caused by a manufacturing fault. As a result, between 5,000 to 10,000 cylinders had to be recalled for hardness testing.

The American Gas Association (AGA) undertook a survey in 1987 which compared accident data during fleet trials of bi-fuel (gasoline and CNG) vehicles at natural gas utilities with conventional vehicles throughout the U.S.⁸¹

Incidence rates, reported in Exhibit VIII-4, are based on a cumulative mileage of 434 million miles for the natural gas fleet. It should be pointed out that one cannot draw definitive conclusions from the data, given the specific nature of the natural gas fleet and the diverse nature of the control (gasoline) fleet. However, the data shows that while both fleets had nearly identical collision rates, 1134 per 100 million miles for natural gas and 1088 per 100 million miles for gasoline. Furthermore, no injuries or deaths were directly attributable to natural gas use.

Exhibit VIII-4. Natural Gas Accident Data-U.S. Experience

Vehicle In Use Incident Rate (Per 100 Million Miles)							
		Fires		Injuries		Deaths	
Vehicle Type	Collision Rate	Total	NGV*	Total	NGV*	Total	NGV*
Natural Gas Fleet	1134.6	2.3	0.5	10.1	0	0	0
Gasoline- Control**	1088.6	N.A.	--	63.7	--	2.5	--

80 Potts, R.E; "NGV - An International Perspective." NGV-88, Sydney.

81 American Gas Association; "Planning and Analysis Issues: Natural Gas Vehicle Safety Survey-An Update." Issue Brief 1987-6. June 26, 1987.

Exhibit VIII-4. Natural Gas Accident Data-U.S. Experience (Continued)

Vehicle Not In Use Incident Rate (Number of Incidents)						
	Fires		Injuries		Deaths	
	Total	NGV*	Total	NGV*	Total	NGV*
Natural Gas Fleet	20	12	7	7	0	0

Notes: N.A. denotes not available.

* denotes directly attributable to CNG system failure.

** U.S. national average, 1985.

Source: American Gas Association; *Planning & Analysis Issues: Natural Gas Vehicle Safety Survey - An Update*. Issue brief 1987-6. June 26, 1987.

According to the AGA survey, the vehicle fire rate on natural gas vehicles was 2.3 fires per 100 million miles. Fires directly attributable to the natural gas system only comprised 22% (0.5 fires per 100 million miles) of the total. Hence, fires are more likely to be initiated due to other causes, for example the electrical system. Although there is not sufficient data to compare fire rates between fuel types, data based on experience in New Zealand reported a much lower incidence of fire on natural gas vehicles than conventional fuel vehicles.⁸²

The survey also reported a total of 12 out of 20 vehicle fires and a number of injuries all directly attributable to natural gas while the vehicle was not in use. The fires included 8 during refuelling, 2 during tank venting and one due to the CNG electric system. The data indicates that fires are most likely to occur during refuelling (8 out of 20 reported fires) and not while the vehicle is in service. This could pose a concern for self serve fuelling. However, there is no data to evaluate whether the fire rate during NGV refuelling is any greater than that from the gasoline fleet.

⁸² EBASCO Services Inc; "Safety Analysis of Natural Gas Vehicles Transiting Highway Tunnels." Report prepared for N.Y.S. Energy Research and Development Authority, Brooklyn Union Gas Company and Consolidated Edison Company of New York. August 1989. (Report in EPA document).

The majority of injuries associated with NGVs consisted of burns sustained during refuelling, however the survey does not report whether these occurred during the previously mentioned fires or were cryogenic burns due to the temperature drop across the refuelling nozzle.

Based on what is known, many researchers have tentatively concluded that methane should be at least as safe, if not safer, than gasoline.⁸³

With respect to LNG, there is virtually no data regarding safety and risk issues for LNG vehicles because of the limited experience with LNG vehicles.

C. REGULATORY RESPONSE

Countries with some tradition in NGVs have formed specific regulations. The first was Italy. Many early regulations were written to prevent all possible accidents, however unlikely, as there was no previous experience to build upon. Some of the early regulations, like concrete walls around a refuelling station, are still in existence. Italian regulations were reviewed to some extent in the early 1990s. Next to form its own legislation was New Zealand. It was mainly based on Italian philosophy, with some modifications based on local experience.

Canada, the U.S.A. and Australia are in the process of completing regulations. Driving forces in the different countries are the Canadian Gas Association, U.S. NGV Coalition and the Australian Gas Association. Countries like the Netherlands and Sweden have just started. In the Netherlands, the Gas Utilities and VEG - Gasinstitut are leading influences. The Co-Nordic Natural Gas Bus Project, backed by OEMs, Gas Utilities, users and Governmental Bodies is the driving force in the Nordic countries. Extensive experience is now available for new regulations to be written.

The philosophy regarding these standards is:

- Draft uniform international standards to increase market competition, and R&D efforts by manufacturers, through avoidance of institutional and protectionist barriers across country borders; and
- Write "Fitness for Purpose" standards for components. The philosophy is that defining a special material quality does not guarantee its fitness for a purpose; the component should meet performance criteria regardless of

⁸³ DeLuchi, M.A, et al; "Methanol vs. Natural Gas Vehicles: A Comparison of Resource Supply, Performance, Emissions, Fuel Storage, Safety, Costs and Transitions." SAE paper 881656.

the material used. Manufacturers get the liberty to choose materials and, to some extent, production methods. It is expected that technical development will, therefore, be very fast and market oriented.

With respect to LNG, there are no standards that apply directly to its use as a vehicle fuel. Standards have been written for large LNG facilities which may not be directly applicable to vehicles. Work is underway in North America to develop specific LNG vehicle standards.

D. EXTRACTION, PROCESSING AND DISTRIBUTION

Natural gas has been extensively used as an energy source for commercial and residential heating for many decades. Over this period the industry has become well acquainted with the properties of natural gas and its safe handling. Exhibit VIII-5 depicts the occupational hazards of various energy production sources. Overall, petroleum and natural gas resource extraction activities are the safest activities when measured in terms of fatalities or lost work days. This industry accounts for approximately 1.1 to 1.2 deaths per 10^{15} BTU. Similarly, the petroleum industry has the fewest lost work days per unit of energy extracted, 1.8 to 2.1 thousand worker days lost per 10^{15} BTU, as compared with other energy production industries. There was no data to differentiate between the oil and gas sector since both tend to be an integral part of a well. The low fatality and injury rate can be attributed to the continuous extraction of oil and gas. Conversely, an activity such as coal mining can be extremely hazardous because of the nature of the mining operation.

It should be pointed out that the actual fatality and injury rates can vary greatly between countries. Fatality and injury rates in countries which have adopted work place health and safety rules are more likely to be lower.

The primary means of distributing natural gas include pipeline and LNG ship. Pipelines can be used to transport gas from the wellhead, through processing to commercial and residential consumers. Pipeline transport is the most economical means of moving large volumes of gas. Marine transport of liquefied natural gas provides a means of intercontinental transport where pipelines do not exist or cannot be constructed.

Pipeline transport is the safest means of transport. Historical records indicate that pipelines have the fewest fuel spills. Pipelines have the capability to automatically shutoff throughput in the event of a spill or release, thus limiting the amount of product released. Exhibit VIII-6 presents a normalized ranking of fatalities per tonne mile for four common transport modes used to carry hazardous materials. Compared to pipeline

transport, which has a baseline value of 1, truck transport would have 1000 times more fatalities. This is because trucks tend to be widely dispersed and must interface with other road traffic.

Exhibit VIII-5. Occupational Hazards of Energy Production

Production Activity	Fatality Rate	Lost Workdays
	(Deaths Per 10 ¹⁵ BTU)	(Thous. work days lost per 10 ¹⁵ BTU)
Petroleum (Oil & Gas), extraction and refining	1.1-1.2	1.8-2.1
Coal mining and liquid fuels from coal	17-25	28-42
Biomass waste to fuel	1.3-15	3.2-41
Wood production and conversion	10-28	36-91

Source: Morris, G. (Energy Resources Group, University of California); "Integrated Assessment Issues Raised by the Environmental Effects of Biomass Energy Systems." Report ERG-WP-80-6. 1980.

Exhibit VIII-6. Relative Hazard Ranking of Various Transport Modes

Mode of Transport	Normalized Ranking
	(Fatalities per tonne mile)*
Pipeline	1
Marine	33
Rail	200
Truck	1000

* Based on Transport of Hazardous materials.

Source: Sperling, D.; "New Transportation Fuels - A Strategic Approach to Technology Change." University of California Press, Berkeley, Ca. 1988. p358.

Although there is a public perception of danger associated with marine shipments of LNG, risk assessment studies have indicated that the risks associated with an LNG terminal are negligible by most standards.⁸⁴

E. SUMMARY

The chemical and physical properties of natural gas make it a relatively safe fuel compared with gasoline or diesel. Although natural gas has a wider flammability range than either fuel, it requires a greater amount of energy to ignite. Furthermore, in the event of a release, it will be in a gaseous state and will rapidly disperse. Natural gas is relatively benign compared to gasoline or diesel. It cannot be ingested and does not cause any skin irritation. The only risk is from inhalation, in which case, if the gas concentration is great enough, it can displace oxygen and act as an asphyxiant.

For LNG, precautions must be taken to prevent frost bite and to ensure proper venting. Risks associated with large spills are not considered to apply to smaller spills in vehicle use.

There have been a number of safety issues raised over the use of natural gas in vehicles. These include the long term integrity of the vehicle fuel system, especially fuel lines, valves and fittings, self serve refuelling, as well as vehicle conversions and aftermarket service.

However, many of these concerns have proven to be ill founded. Limited in-use statistical data seems to indicate that NGVs have an excellent safety record and are not inherently more dangerous than either gasoline or diesel vehicles. Similarly the natural gas extraction and processing industry is one of the safest production industries today. Pipeline transport, the principal means of gas distribution, is the least hazardous means of transport compared with marine, rail and truck.

International safety regulations pertaining to natural gas vehicles are still in their infancy. However, the natural gas industry has recently recognized the need to create international standards to increase competition and avoid protectionist barriers. Concurrent with more competitive uniform international standards, the industry is trying to move towards "fitness for purpose" standards for components. Fitness for purpose standards would establish performance criteria and allow individual manufacturers latitude to choose materials and, to some extent, production methods. It is expected that this will accelerate technical development.

⁸⁴ Keeney, R.L., et al; "Assessing the Risk of an LNG Terminal", Technology Review (October 1978): pg. 64-72.

IX THE ECONOMICS OF METHANE AS A MOTOR FUEL

A. INTRODUCTION

Three key factors that determine the economic feasibility of operating vehicles on methane are:

- The engine and vehicle price differential (i.e., conversion cost for existing vehicles, price differential for new OEM vehicles);
- The price differential, on an energy equivalent basis, between natural gas and the conventional fuels it displaces (gasoline or diesel); and
- The cost of the type of refueling system (fast fill, slow fill, mother-daughter) and storage system (compressed or liquefied).

National differences in taxing structures, environmental regulation, the capacity of the distribution system, and the price of natural gas make it difficult to reach a macro level (i.e., worldwide) conclusion about the economic feasibility of NGV. The feasibility can even vary from jurisdiction to jurisdiction within large countries such as Canada, the United States, Australia or Mexico.

The feasibility in one political jurisdiction or geographic area can also vary depending on the specific application. In general terms, the lower price of natural gas is used to offset the higher costs incurred for the refueling station and conversion of NGVs. As the amount of fuel consumed increases, the fuel cost savings also grow. Therefore, generally, the more fuel consumed, the greater the likelihood of a conversion for particular application being feasible.

These site factors mean that most economic assessments of the feasibility of natural gas conversions are undertaken for very specific applications, with well defined assumptions and costs.

The analysis in this section includes the following:

- A review of published documentation on the financial and economic viability of NGVs. This survey reveals a range of results, but provides some indication of applications that NGVs are economically or financially feasible.

- Presentation and discussion of the results of an analytical model used to illustrate the relationship between major cost factors, and to provide further insight into economically viable applications and regions.

B. REVIEW OF LITERATURE

Canadian Studies

Canada presently consumes about 130 billion cubic metres of natural gas per year. If natural gas vehicles were to capture 5% of the total market (today they are less than .02%) they would consume about 6.5 billion cubic metres of natural gas per year. This increase is well within the capacity of the existing transmission and distribution system in the country. The available capacity in the distribution system has a positive impact on the economic analysis of NGVs as the cost of new pipelines and other transmission facilities does not need to be reflected in the cost of the natural gas supply.

In 1991, the Canadian Energy Research Institute (CERI) prepared a report examining the feasibility of natural gas in a number of fleet types.⁸⁵ At the time of the report, the price differential between natural gas and gasoline varied nationally from Cdn\$0.29 on the west coast to Cdn\$0.19 in Quebec on a per litre, energy equivalent basis. (This differential included federal and provincial fuel taxes between Cdn\$0.16 and Cdn\$0.20 per litre applied to gasoline.) The cost of fuelling stations and vehicle conversions is, on the other hand, generally the same across the country. Therefore the greater the price differential, the more attractive the natural gas option becomes.

Exhibit IX-1 summarizes the net benefit of conversions for a range of assumed conversion costs. CERI uses base, optimistic and pessimistic scenarios for conversion costs. In the analysis, the natural gas price differential from gasoline is Cdn\$0.25 per litre equivalent (Cdn\$7.10/GJ). For diesel, the differential is Cdn\$0.15 (Cdn\$4.20/GJ). The price differential between diesel and natural gas is lower because each litre of diesel has more energy content than gasoline, and it is taxed at a lower rate.

The exhibit indicates that in Canada it is very difficult to economically justify the conversion of private, light duty vehicles. However similar vehicles in fleet operation with higher annual fuel usage offer very attractive benefits. In heavy duty vehicle and transit bus applications, the feasibility is driven by the conversion costs. Where the heavy duty engine is replaced by a converted gasoline engine, and conversion costs are relatively low, the fleet vehicles

⁸⁵ Michelle Heath, "Alternative Transportation Fuels", Canadian Energy Research Institute, Calgary, 1991.

Exhibit IX-1. Lifetime Fuel Savings From Natural Gas Conversion

	Assumptions		Life (years)	Conversion Costs (Cdn\$)			Fuel Savings (Cdn\$) Discounted (10%)		Net Benefit (Cdn\$)		
	L/100 km	km/yr		Optimistic	Base	Pessimistic	Optimistic	Discounted	Optimistic	Base	Pessimistic
Light Duty Personal Vehicles ^a	12.5	20,000	5	2,200	2,800	3,200	2,485	2,485	285	-315	-715
Light Duty Fleet ^a Vehicles ^a	12.5	75,000	5	2,200	2,800	3,200	9,318	9,318	7,118	6,518	6,118
Heavy Vehicles (> 3855.6 kg ^b)	35	40,000	7	3,200	3,700	4,200	10,723	10,723	7,523	7,023	6,523
Heavy Vehicles (≈ 47,000 kg ^b)	46	70,000	7	20,000	22,500	25,000	24,662	24,662	4,662	2,162	-337
Urban Bus ^b	53	50,000	16	20,000	35,000	50,000	32,617	32,617	12,617	-2,383	-17,383

Source: Canadian Energy Research Institute.

Note: Net benefits do not include any infrastructure costs.

a Price differential from gasoline is 25 cents per litre equivalent energy (Cdn\$7.60/GJ).

b Price differential from diesel fuel is 15 cents per litre equivalent energy (Cdn\$4.20/GJ).

offer excellent paybacks. In cases where heavy duty diesel engines must be converted to natural gas, and large volumes of gas must be stored onboard the vehicles, the conversion cost is critical.

Urban transit bus applications have received a considerable amount of attention in Canada in recent years. Conversion programs are now underway at three properties in Ontario and one in British Columbia with studies underway at several other systems. The most detailed economic assessments have been done by the Government of Ontario on behalf of fleets in Toronto, Hamilton and Mississauga. The major impetus for these conversions has been issues related to security of fuel supply and air quality.

The life cycle costing analysis of urban transit buses in Ontario was based on current technology and 1989 fuel prices for natural gas, diesel and other alternative fuels. The study assumed a Cdn\$35,000 additional capital cost for a bus, a fleet of 250 vehicles with a single fast fill compressor station, and fuel costs of Cdn\$0.135/m³ (Cdn\$3.70/GJ) for natural gas, Cdn\$0.37/litre (Cdn\$10.20/GJ) for current diesel fuel, and Cdn\$0.46/litre (Cdn\$12.70/GJ) for future low-sulphur diesel.⁸⁶ Low sulphur fuel will be required in the future to meet new emissions regulations. In addition, diesel engines will probably need to use particulate traps and/or oxidation catalysts. Thus, future "clean" diesel technology will cost more.

The study concluded that under the current tax structure, it would cost Cdn\$0.20/100 km less over the life of the bus to operate on natural gas as compared to diesel. Clean diesel was forecast to cost about Cdn\$7.60/100 km more to operate than current diesel buses. If the tax structure was changed to treat all fuels equally, natural gas would cost about Cdn\$5.20/100 km more to operate over the life cycle of the vehicle when compared to current diesel. Under the revised tax structure, clean diesel was estimated to cost about Cdn\$7.10/100 km more than current diesel to operate.⁸⁷ The life cycle costs for natural gas did not include the potential impact of reduced passenger carrying capacity of the NGV buses that is the result of the significant weight penalty imposed by the fuel storage cylinders. Based on typical Canadian transit buses and permitted axle loadings, the capacity of a natural gas would be reduced by about 16-20% or 15 passengers. If buses are operated at full capacity, this could represent a significant additional cost penalty for natural gas as a result of either adding more buses, or adding an additional axle.

⁸⁶ M. D. Harmelink, "Ontario's Natural Gas Bus Development Program", Presentation to B.C. Alternative Fuel Symposium, 1990.

⁸⁷ M. D. Harmelink, "Ontario's Natural Gas Bus Development Program", Presentation to B.C. Alternative Fuel Symposium, 1990.

In Canada, NGVs in high mileage fleet applications appear to be assured of continuing economic viability as long as the current price differential remains or improves. To maintain, the differential it will be necessary to maintain tax programs now in effect or see prices for crude oil increase relative to natural gas.

American Studies

In the United States, the American Gas Association reports that the natural gas price differential in recent years has varied between \$0.12 and \$0.18 per gasoline litre equivalent (\$3.60 - 5.50/GJ). At \$0.18 per litre (\$5.50/GJ) differential, the American Gas Association estimates the payback period for an OEM light duty vehicle at under 1 year, while for converted vehicles the payback is estimated at 2 to 4 years exclusive of infrastructure costs.⁸⁸

The Environmental Protection Agency of the United States has completed an analysis of the economic and environmental effects of compressed natural gas (CNG) as a vehicle fuel for passenger cars and light trucks as well as heavy duty vehicles.⁸⁹

The EPA study (volume 1) includes a comprehensive examination of the pricing of natural gas for use in light duty vehicles. The study examines all of the factors that go into determining the retail price of natural gas, including:

- Production and refining;
- Transportation and distribution;
- Fuel station construction and operation; and
- Markup and taxes.

The EPA uses all of these factors to calculate the gasoline and natural gas energy equivalent fuel prices for a range of alternatives based on the amount of fuel being delivered per filling station. Two alternative natural gas prices are projected based on the energy source used to power the refuelling station compressor. The results are shown in Exhibit IX-2.

The data in Exhibit IX-2, which has been generalized to fit the overall situation in the U.S.A., results in a best case price differential of \$0.08 per litre equivalent (\$2.40/GJ). This is substantially less than the \$0.16 to \$0.24

⁸⁸ American Gas Association, "Natural Gas: Where the Action Is", *Intercom*, November 1990.

⁸⁹ United States Environmental Protection Agency, "Analysis of the Economic and Environmental Effects of Compressed Natural Gas as a Vehicle Fuel," Volumes 1 and 2, April 1990.

light duty truck in a fleet operation, the payback would occur in 4 years; assuming fuel consumption at 12 litres/100km, and an annual mileage of 75,000km, EPA's average conversion costs.

The EPA also estimates costs of \$1,600 for dual fuel and \$900 for dedicated OEM light duty vehicles in mass production. If these costs are substituted in the previous examples, the payback periods are reduced to 8 and 5 years respectively for the private passenger car; and 2 and 1 year respectively for the light duty truck.

These results indicate that light duty NGVs may be economically viable in the U.S. in applications where there are vehicles with high fuel consumption or very low conversion or acquisition costs. Conversions may also be economically viable in specific states or communities where tax remissions, environmental legislation or utility rebates and subsidies enhance the financial attractiveness of natural gas.

In the EPA's analysis of heavy duty vehicles, they concluded that:

"a stoichiometric combustion CNG engine offers a significant potential fuel cost savings over an equivalent gasoline engine. Conversely, the fuel economics of replacing a diesel engine with a dedicated CNG engine are not as good, especially with current CNG technology. This was to be expected given the fact that diesel engines already represent a very efficient form of fuel consumption and the relatively lower cost of diesel fuel compared to gasoline."

The EPA's fuel cost comparison included the price of the natural gas, as well as distribution, compression capital and operating costs. The EPA results are shown in Exhibit IX-3.

The EPA also concludes that *the only area which is expected to increase the cost of heavy duty CNG vehicles to any significant degree is that of fuel storage.* The net cost increase (cost of fuel storage cylinders less the cost of diesel tanks not required) is estimated to be from \$1,990 to \$9,900 depending on the type of installation and the number of cylinders. The high end costs are for a transit vehicle, and they represent an increase in cost per vehicle of about 5%. The EPA also mentions that the weight and size penalty from the large storage requirements may impact some applications. As discussed in the section concerning transit applications in Canada, this penalty could be significant.

These conclusions for heavy duty vehicles differ from those of Canadian studies illustrating differences in fuel costs and taxation structure. It should also be noted that the EPA does not show any increase in diesel fuel prices

that are anticipated for lower sulphur diesel fuels required to meet new emissions regulations.

Exhibit IX-3. Heavy Duty Vehicle Fuel Cost Comparison (U.S. EPA)

Vehicle Fuel Costs (Litre Equivalent) Energy		
Gasoline Comparison		
	Current	Optimized (future)
Gasoline:	\$0.29	-
CNG Stoichiometric:	\$0.18 - \$0.30	\$0.17 - \$0.29
Diesel Comparison		
Diesel Fuel:	\$0.25	-
CNG Lean Burn Combustion:	\$0.32 - \$0.54	\$0.28 - \$0.48

World Bank Studies

The World Bank is involved in tracking the economic feasibility of alternative fuels in developing countries. Their analysis of the economic feasibility of natural gas is of particular interest since they are concerned with the economics on a world wide scale. Although their work is geared towards the developing world, their cost and technology assumptions are based on the experience of the leading industrial countries that have operating NGV fleets.

The World Bank has also attempted to overcome the overwhelming complexity that characterizes economic assessment of natural gas vehicle conversions by developing a limited number of fleet scenarios based on crude oil and city gate natural gas prices. In a paper presented to the Gaseous Fuels Conference in Vancouver in 1986, the Bank introduced a model that examined the eight possible fleet scenarios. The eight scenarios represented a cross section of applications ranging from private automobiles to heavy duty trucks and buses. The range of scenarios also included a variety of refuelling options suited to the particular fleet applications. The types of applications and the conversion and fuel use assumptions for each of the eight scenarios is shown in Exhibit IX-4.⁹⁰

⁹⁰ World Bank, "On The Techno-Economics of CNG Utilization For Vehicle Transport", Gaseous Fuels Conference, Vancouver 1986.

Exhibit IX-4. World Bank Economic Model Assumptions

	Conversion Cost US\$	Annual Fuel Use in Litres
Private gasoline car	1,010	1,474
Company gasoline car	1,010	272
Taxi (diesel)	1,775	6,825
Pickup truck (diesel)	1,620	4,808
20 Ton truck (diesel)	2,670	15,075
Minibus (diesel)	2,085	12,167
City Bus (diesel)	2,265	22,344
Intercity Bus (diesel)	3,150	24,083

The model also considered crude oil prices of US\$10 - US\$25 per barrel and natural gas prices of around \$1.25/GJ exclusive of all taxes. This figure, although based on 1986 price levels is still near the 1991 natural gas cost in the U.S. The conversion costs quoted in the study are low by current standards and are more representative today of the price differential that would be expected for an OEM produced, dedicated NGV.

Under these assumptions the World Bank concluded that NGV was economically viable for dedicated fleet vehicles if crude oil prices are \$20 per barrel or greater, and natural gas prices are less than \$1.25/GJ. In private vehicles, the Bank concluded that the economic break-even point would not occur until the price of crude oil reaches a range of \$40 to \$50 per barrel. It should be noted that the World Bank's analysis excludes fuel taxes to arrive at economic costs.

In a more recent study, the World Bank studied the price of crude oil that would be required to make natural gas an economically alternative fuel.⁹¹ In this study, the bank assumes conversion costs of \$1,000 to \$4,500 depending on the type of vehicle. The World Bank concluded that CNG today would not be competitive in cars with crude oil prices of less than \$45 per barrel, with gas well head prices of about \$1/GJ and short transmission pipelines. (See Exhibit IX-5) The most promising applications are public transportation (taxis and buses) where gas is available locally and slow fill systems are used.

91 John B. Homer, "CNG Vehicles In Developing Countries", World Bank, June 1991.

Summary Of Literature Review

From the review of literature, it can be seen that the most promising application for NGVs are fleet vehicles with high annual fuel consumption and minimized conversion and fuelling station costs. The least favourable is passenger cars with low mileage that use after market conversions.

Exhibit IX-5. World Bank Analysis: Break-Even Crude Oil Price (US\$/bbl) with a Gas Price of US\$1/GJ

Vehicles	<u>Fast Fill</u> Transmission		<u>Slow Fill</u> Transmission	
	Local	Distant	Local	Distant
Cars	45	55	36	46
Taxis	27	36	18	28
Light Trucks	44	54	35	45
Buses	27	38	18	29

Notwithstanding this general conclusion, there can be individual situations where natural gas can be financially viable in other applications. Regional or jurisdictional variations such as tax remissions, subsidization, environmental regulation or the availability of lower cost natural gas can have a great impact on the viability of this fuel.

C. ANALYSIS

The authors of this report have prepared and used an analytical computer model to illustrate the relationship between major factors in the economic and financial feasibility of NGVs. These major cost factors include the following:

- The price differential between natural gas and gasoline, or diesel, as delivered to the vehicle.
- The extra costs of after market conversions, or the incremental costs of new OEM vehicles equipped to operate on natural gas.
- The annual distance travelled by the vehicle and thus the fuel consumed.
- The type of fuelling station that is used.

- The impact of fuel taxes.

Assumptions were simplified as much as possible to show the relationship between these variables. The model was also used to indicate vehicle applications and geographical regions for which natural gas would be economically viable.

The following major scenarios were analyzed in detail:

- Light Duty Vehicles - Passenger Car Applications
 - 20,000 km per year, 6 year life;
 - use of public fuelling station; and
 - Scenario "1-A" used bi-fuel conversion technology currently available, and Scenario "1-B" projected the use of optimized OEM technology.
- Light Duty Vehicles - Fleet Applications:
 - 60,000 km per year, 5 year life; and
 - other assumptions as per scenarios 1-A and 1-B.
- Heavy Duty Diesel - Urban Transit Bus - Fast Fill Refuelling
 - 60,000 km per year, 15-year life;
 - \$20,000 incremental cost per bus; and
 - \$23,000 per bus for fast-fill fuelling station.
- Heavy Duty Diesel - Urban Transit Bus - Slow Fill
 - 60,000 km per year, 15 year life;
 - \$20,000 incremental cost per bus; and
 - \$1,500 per bus for fuelling station costs.

1. Analysis Of Light Duty Scenarios

The computer model used Discounted Cash Flow analysis to analyze the major cost factors. A discount rate of 5% was used to show the results in "real" terms. A real return of 5% corresponds to a nominal rate, including inflation of about 10%. The model was used to determine the price of natural gas that would be required to provide a net present value greater than zero, thus indicating economic viability. The initial analysis excluded fuel taxes that are normally applied to gasoline. The resultant price of natural gas was then compared to projected gas prices that could be expected in North America, Japan and Europe.

The natural gas price refers to the price as supplied to the fuelling station before handling and compression. These cost factors for the fuelling station include: compression costs, maintenance, operation, and financing. Based on actual experience, the Government of Ontario has estimated these costs at \$0.14 per cubic metre (\$3.87/GJ) of natural gas.⁹² The EPA has projected a range of \$0.11 to \$0.28 per cubic metre (\$3.00 - \$7.75/GJ).⁹³ The analysis has used \$0.14 per cubic metre (\$3.87/GJ) throughout for simplicity of analysis. Actual costs in Europe and Japan would vary somewhat from these figures depending on local labour rates, energy costs and capital costs.

Exhibit IX-6. Passenger Car Application: Current Technology

BASIC ASSUMPTIONS			
Life (years)			6
Km/yr			20000
Fuel consumption (L/100 km)			12
Fuelling Station Capital Cost			\$250,000
SCENARIO 1-A: BI-FUEL (CURRENT TECHNOLOGY)			
Conversion Cost			\$2,500
Natural Gas Utilization (percent)			90%
NG Energy Efficiency (percent)			110%
Gasoline Price (without taxes - \$/L)			\$0.30
Fuelling Station O&M Costs (\$/cu.m.)			\$0.140
		(\$/Le)	\$0.127
NG Price To Station (per cu.m.)			\$0.000
NG Price To Station (per Litre Equivalent)			\$0.000
NG Price To Vehicle (per Le)			\$0.127
COST ANALYSIS			
Year	Capital Costs	NG Fuel Savings*	Net Savings
0	(\$2,500)		(\$2,500)
1		\$346	\$346
2		\$346	\$346
3		\$346	\$346
4		\$346	\$346
5		\$346	\$346
6	990	\$346	\$1,336
Net Present Value			(\$7)

⁹² Ministry of Transportation of Ontario, Canada, "The Economics of Building NGV Infrastructure In Canada", Presentation to World Bank Seminar, June 1991.

⁹³ United States Environmental Protection Agency, "Analysis of the Economic and Environmental Effects of Compressed Natural Gas as a Vehicle Fuel," Volumes 1 and 2, April 1990.

Conventional Bi-Fuel Technology- Passenger Car Application

The assumptions and initial analysis of Scenario 1-A is shown in Exhibit IX-6. In addition to the assumptions stated previously, a conversion cost of \$2,500 is used. A residual value is estimated at the end of the car's life accounting for the expected 15 year life of natural gas cylinders. Associated with bi-fuel technology, it is assumed that the vehicle will operate on natural gas 90% of the time, and on gasoline 10% of its operation. Operation on natural gas incurs an additional 10% energy consumption relative to the baseline gasoline vehicle before conversion.

A gasoline price, excluding fuel taxes, of \$0.30 (\$9.09/GJ) per litre was assumed. Under this scenario, natural gas would have to be provided free to the fuelling station for a Net Present Value greater than zero. Obviously, this scenario is not realistic. This confirms studies by the EPA, the World Bank and CERL.

This scenario is much more attractive if motor fuel taxes are applied to gasoline and not to natural gas. The analysis was rerun for each of the participating IEA member countries using recent fuel taxes. To simplify the analysis, the price for natural gas to the station was assumed to be \$0.12 per cubic metre (\$3.30/GJ). This would correspond to \$0.06 per cubic metre (\$1.65/GJ) at the wellhead and allow \$0.06 (\$1.65/GJ) for transmission and distribution. The resultant Net Present Values of the benefits are shown in Exhibit IX-6. With taxes applied to gasoline, NGV using conventional bi-fuel technology is financially viable in all countries except the United States. As shown in Exhibit IX-7, the financial viability is extremely attractive in Europe. There was insufficient data available at the time of this draft report to draw any conclusions about Japan.

Exhibit IX-7. NPV of NGV in Passenger Cars
(including Fuel Taxes) (U.S. \$)

	Gasoline (Ex. Taxes) (\$/litre)	Fuel Tax (\$/litre)	Total Fuel Cost	Net Present Value	
				(Bi-fuel)	(OEM)
Canada	\$0.26	\$0.21	\$0.47	\$540	\$2,100
Finland	0.40	0.65	1.05	6,900	9,200
Italy	0.30	0.85	1.15	8,000	10,400
Japan*	0.43	0.37	0.80	4,200	6,200
Sweden	0.37	0.72	1.09	7,300	9,700
U.S.A.	0.23	0.09	0.32	-1,103	300
Netherlands	0.43	0.47	0.90	5,300	7,400

Note: Fuel prices during July 1991

* Second quarter of 1990

OEM Technology - Passenger Car Application

If an OEM built vehicle is assumed, then the economics is more positive. There should be a 10% increase in energy efficiency relative to gasoline instead of a 10% penalty. It is also assumed that the vehicle will run all the time on natural gas. Such a car should cost about \$1000 more than a conventional vehicle. Under these assumption, a natural gas price of \$0.12 per cubic metre (\$3.30/GJ) will make this scenario economically viable. If fuel taxes are applied to gasoline, the financial feasibility is also very good as shown in Exhibit IX-7.

Light Duty - Fleet Applications

Assuming bi-fuel technology but higher annual distance travelled (60,000 km per year), the economic feasibility, excluding fuel taxes, of natural gas improves considerably. At a natural gas price of \$0.095 per cubic metre (\$2.60/GJ), this scenario shows positive economic results. If OEM technology were available, then a natural gas price of \$0.12 per cubic metre (\$3.30/GJ) would provide a NPV of \$1700. The assumptions for this scenario and results are shown in Exhibit IX-8. The breakeven would be about \$0.19 per cubic metre (\$5.30/GJ).

Conclusions For Light Duty Vehicles

NGVs using current bi-fuel technology are not attractive for low mileage passenger vehicles unless substantial financial incentives are provided in the form, for example, of fuel tax savings.

NGVs, assuming OEM technology were available, would be economically attractive at natural gas prices around \$0.12 per cubic metre (\$3.30/GJ) delivered to the fuelling station, even excluding fuel taxes. This scenario would appear to be possible in most of the IEA countries except possibly the United States that has very low gasoline prices.

The economic and financial feasibility of NGVs increases as the annual distance and fuel consumption increases as in the case for fleet applications. Some tax relief would still be required for vehicles using current technology, but high mileage OEM fleet vehicles could provide positive economic results.

Exhibit IX-9 summarizes the price of natural gas delivered to the fuelling station that is required for an economic breakeven using net present values for the scenarios examined. This economic breakeven excludes fuel taxes.

Exhibit IX-8. Fleet Application - OEM Technology

BASIC ASSUMPTIONS			
Life (years)		5	
Km/yr		60000	
Fuel consumption (L/100 km)		12	
Fuelling Station Capital Cost		\$250,000	
SCENARIO 2: OEM TECHNOLOGY :			
Conversion Cost		\$1,000	
Natural Gas Utilization (percent)		100%	
NG Energy Efficiency (percent)		90%	
Gasoline Price (without taxes - \$/L)		\$0.30	
Fuelling Station O&M Costs (\$/cu.m.)		\$0.140	
	(\$/Le)	\$0.127	
NG Price To Station (per cu.m.)		\$0.120	
NG Price To Station (per Litre Equivalent)		\$0.109	
NG Price To Vehicle (per Le)		\$0.236	
COST ANALYSIS			
Year	Capital Costs	NG Fuel Savings*	Net Savings
0	(\$1,000)		(\$1,000)
1		\$628	\$628
2		\$628	\$628
3		\$628	\$628
4		\$628	\$628
5		\$628	\$628
Net Present Value			\$1,720

Exhibit IX-9. Summary of Delivered Gas Prices For Breakeven

Scenario	Delivered Gas Price	
	(\$/m ³)	(\$/GJ)
Passenger Car: Bi-fuel Technology	\$0	\$0
Passenger Car: OEM Technology	\$0.12	\$3.30
Fleet Cars: Bi-fuel Technology	\$0.095	\$2.60
Fleet Cars: OEM Technology	\$0.19	\$5.30

2. Analysis Of Heavy Duty Scenarios

The heavy duty scenarios that were analyzed were urban transit buses using either a fast-fill facility or slow-fill station. Transit buses were selected for

analysis because a lot of development has recently been directed at using natural gas in this application. Some relevant cost information is, therefore, available. Conclusions regarding truck applications were made by inference from the analysis of the bus application.

A discounted cash flow analysis was used, as for light duty applications, to determine the price of natural gas delivered to the station that would be required for breakeven. For the heavy duty analysis, the costs for the fuelling station include only compression and maintenance. The capital cost is included in the cash flow analysis. No incremental labour cost is assumed relative to diesel fuelling. The resultant operating cost for the fuelling station was estimated at \$0.05 per cubic metre (\$1.40/GJ).

Another major assumption was that maintenance costs for natural gas buses were the same as for diesel-fuelled buses. It should be noted that the technology for natural gas in this application is in the early stages of development and field trials, and has not yet reached the same level of reliability and durability as diesel. This is an important goal of vehicle development. The analysis also does not include the possible impact of reduced passenger capacity as a result of the extra weight of fuel tanks.

Urban Transit Bus - Fast-Fill Fuelling

This scenario includes the use of a fast fill facility to handle high volume fuelling at the end of shift changes. As described in the section on refuelling stations, this approach requires a major investment in fuelling capacity. A cost of \$23,000 per bus is assumed for the station. Capital costs for the bus were set at \$20,000 per bus. The current costs for NGV buses in North America have ranged from \$50,000 to \$70,000 more than a diesel bus. The price of diesel fuel, excluding taxes, that was used was \$0.25 per litre (\$6.90/GJ). Prices in Sweden and Finland are somewhat higher. Other assumptions and the analysis for this scenario are shown in Exhibit IX-10. Based on the assumptions shown, natural gas would have to be delivered to the station at about \$0.06 per cubic metre (\$1.65/GJ). If the price of the bus were reduced to \$10,000 as predicted by the EPA, then breakeven is at about \$0.095 (\$2.60/GJ) per cubic metre.

The results so far exclude any fuel taxes that would be applied to diesel and possibly not to natural gas. If these taxes are included, then the financial feasibility of NGV, as shown in Exhibit IX-11, is extremely attractive in all countries.

The analysis so far does not take into account the possible higher costs of diesel technology that may be required to meet new emissions control regulations. Studies by the authors have estimated this cost at up to \$4000

per bus plus an extra \$2000 yearly for operations and maintenance. Under these assumptions, the breakeven point is \$0.14 per cubic metre (\$3.90/GJ).

Exhibit IX-10. Urban Bus Application: Fast-Fill

BASIC ASSUMPTIONS			
Life (years)			15
Km/yr			60,000
Fuel consumption (L/100 km)			50
Fuelling Station Costs (per bus)			\$23,000
Vehicle Capital Costs			\$20,000
Natural Gas Utilization (percent)			100%
NG Energy Efficiency (percent)			100%
Diesel Fuel Price (without taxes - \$/L)			\$0.250
Fuelling Station O&M Costs (\$/cu.m)			\$0.050
			(\$/Le)
			\$0.050
NG Price to Station (per cu.m)			\$0.061
NG Price to Station (per Litre Equivalent)			\$0.061
NG Price to Vehicle (per Le)			\$0.111
COST ANALYSIS			
Year	Capital Costs	NG Fuel Savings*	Net Savings
0	(\$43,000)		(\$43,000)
1		\$4,170	\$4,170
2		\$4,170	\$4,170
3		\$4,170	\$4,170
4		\$4,170	\$4,170
5		\$4,170	\$4,170
6		\$4,170	\$4,170
7		\$4,170	\$4,170
8		\$4,170	\$4,170
9		\$4,170	\$4,170
10		\$4,170	\$4,170
11		\$4,170	\$4,170
12		\$4,170	\$4,170
13		\$4,170	\$4,170
14		\$4,170	\$4,170
15		\$4,170	\$4,170
Net Present Value			\$283

Urban Bus - Slow Fill Facilities

This scenario assumes that the vehicles can be stored and fuelled outside overnight, using slow fill facilities. Outdoor storage has been shown to be feasible in cold climates for diesel buses in Sweden. This scenario has the advantage of greatly reducing the cost of the fuelling station from about \$23,000 per bus to about \$1,500. Under this scenario, the breakeven price of

natural gas delivered to the station is estimated at \$0.13 per cubic metre (\$3.60/GJ). Thus the economic feasibility improves significantly and would appear attractive in most IEA countries.

**Exhibit IX-11. NPV of NGV in Urban Buses
(including Fuel Taxes) * (U.S. \$)**

	Diesel Fuel Tax (\$/litre)	Total Cost (\$/litre)	NPV
Canada	\$0.17	\$0.42 **	\$34,800
Finland	0.37	0.70	122,000
Italy	0.46	0.70	122,000
Japan **	0.15	0.44	37,800
Sweden	0.35	0.75	137,600
U.S.A.	0.09	0.34	9,900
Netherlands	0.32	0.52	66,000

* Assume NG delivered at \$0.12/m³ (\$3.30/GJ); \$20,000 extra per bus.

** Includes 5¢/litre discount for fleet bulk purchases.

This scenario is similar to what many heavy duty trucking applications could encounter. Thus, natural gas for heavy duty trucking with high daily mileage would appear to be economically attractive.

Conclusion For Heavy Duty Vehicles

The feasibility of using natural gas is heavily influenced by the type of fuelling facility required. Natural gas for urban bus applications will be economically attractive if fuelling station costs can be minimized. Changes in fleet operations may be required to take advantage of natural gas.

With changes in technology and increases in diesel technology to meet new emissions regulations, natural gas appears to be a competitive alternative.

Natural gas also appears attractive for heavy duty truck applications using either slow fill or public fuelling stations.

Exhibit IX-12 summarizes the price of natural gas delivered to the fuelling station that is required for an economic breakeven using net present values for the scenarios examined. This economic breakeven excludes fuel taxes.

**Exhibit IX-12. Summary of Delivered Gas Prices for
Breakeven: Heavy Duty Vehicle Applications**

Scenario	Delivered Gas Price	
	(\$/m ³)	(\$/GJ)
Urban Bus: Fast Fill		
- \$20,000/NG bus	\$0.06	\$1.65
- \$10,000/NG bus	\$0.095	\$2.60
- \$10,000/NG bus and higher cost diesel technology	\$0.14	\$3.90
Urban Bus: Slow Fill		
- \$20,000/bus	\$0.13	\$3.60

D. SUMMARY

The economic feasibility of NGVs is dependent on a number of key factors including:

- Conversion or incremental OEM costs for the vehicle.
- The price of natural gas in relation to gasoline or diesel.
- The annual fuel consumption of the vehicle.
- The type of fuelling station that is used.
- Tax structure.

These factors are usually analyzed on a site, vehicle application and country specific basis. Nonetheless, it is possible to make some general conclusions about the economic feasibility of NGVs. These conclusions are as follows:

- Conversion of passenger cars to natural gas does not appear economically viable in any of the IEA countries, unless there are substantial fuel tax savings through preferential taxation. This is the situation in Europe and Canada.
- The economic viability of natural gas in passenger cars would increase significantly if built as Originally Equipment Vehicles (OEMs). At a breakeven price of \$0.12 per cubic metre (\$3.00/GJ) for natural gas delivered to the fuelling station, this scenario appears economically reasonable for many IEA locations.

- The economic returns for fleet cars, especially with OEM technology, are the most promising for the light duty vehicle category. Development efforts should be focussed in this area.
- The use of natural gas in heavy duty applications appears to have the potential to be economically attractive in urban bus applications, especially if overnight slow-fill fuelling is possible. Similar conclusions can be made about heavy duty trucking applications that have access to either slow-fill or public fuelling. Changes in diesel technology and increased costs to meet new emissions regulations further increase the potential for natural gas. The use of LNG could reduce the concerns of vehicle weight and range to a large degree.
- Current preferential tax treatment of natural gas makes NGV in heavy duty applications very worthwhile for private-sector fleet operators.

X STRATEGIES FOR FURTHER IMPLEMENTATION

A. STRATEGIC CONSIDERATIONS

There are a number of strategic considerations that strongly favour further investigation, development and implementation of methane as a motor fuel.

- There is justification for NGVs in simple economic terms, particularly in fleet applications, such as urban buses, taxis and delivery vans, with high annual energy consumption.
- NGVs can reduce air quality problems, particularly ozone formation, through lower emissions of non-methane hydrocarbons. Also, NGVs inherently have lower emissions of air toxics and particulates. These air quality problems are most acute in urban centres, thus enhancing the benefits of NGVs in fleet applications that are concentrated in cities.
- If a country is endowed with its own supplies of natural gas, it provides a secure source of transportation fuel. It makes even more sense if the country's population centres are located close to the natural gas supply, thus avoiding expensive transmission costs. For some countries, natural gas can displace domestic consumption of oil and allow for the export of more petroleum products to increase overseas earnings. For those countries not so fortunate, natural gas does diversify the sources of transportation energy away from OPEC countries.
- NGVs can provide employment in the extraction, processing and distribution of natural gas; and in the equipping of vehicles to operate on methane. NGVs can encourage private sector investment in indigenous industry that has the potential for exports.

B. BARRIERS TO IMPLEMENTATION

The most significant barriers to implementation are the following:

- Range limitations: This problem cannot be totally eliminated, but can be reduced through the use of composite material in NGV fuel tanks, and through optimized OEM vehicle design.
- Limited Refuelling Outlets: This issue is part of the classic "chicken and egg" syndrome of introducing new fuels. A number of countries have

introduced major programs to increase the number of fuelling stations, particularly in urban centres.

- **Perceived Lack of OEM Support:** Some users, especially fleet operators, are concerned about a fuel that is not publicly endorsed by major vehicle manufacturers. Increased OEM support in NGVs is an encouraging step in reducing this barrier.
- **Service Network:** There is a need for a viable parts and service network that can maintain a significant population of vehicles, and give potential users confidence that their vehicles can be repaired quickly and at reasonable cost. Increased OEM support will alleviate this problem to some extent.
- **Regulatory Hurdles:** Although there are regulations in place in many countries governing the use of methane in motor vehicles, these regulations may vary among different countries. This practice creates a barrier in the efficient development of NGV equipment. Manufacturers have to create products with specifications to meet specific country needs. Another regulatory hurdle is the acceptance of new materials in NGV high pressure cylinders. Lack of acceptance is delaying the implementation of lighter weight fuel tanks.

C. STRATEGIES FOR FURTHER DEVELOPMENT AND IMPLEMENTATION

Governments working in co-operation with each other and with industry can initiate further implementation of NGVs. The lead times for capitalizing on the benefits of improved NGV technology can be considered to be medium term (3 to 10 years).

The following strategies are suggested for further development and implementation of methane in motor vehicles.

- Continuation, or implementation, of preferential fuel tax treatment and direct subsidy, to help develop the industry in at least the short term until the costs of technology are reduced and a significant fuelling structure is in place. The particular incentives required are dependent on the situation in respective countries.
- Investigation of the effect of variations in gas quality on exhaust emissions.

- Support for the efforts of the IANGV and regulatory bodies to set domestic and international standards for gas quality, NGV cylinders, and vehicle fuelling systems. This support includes working with the regulatory agencies to overcome their concerns, and facilitate acceptance of new technology.
- Further R & D in the use of biogas as a motor fuel.
- R & D in the following areas.
 - engine management systems;
 - catalytic converters for NGVs;
 - optimized engine design;
 - lighter weight methane storage; and
 - noise reduction potential.
- OEM production of NGVs incorporating optimized technology. Market focus should be directed at fleet users with high fuel consumption.
- Development and field trials of LNG in urban transit and heavy duty truck applications.
- Develop a better understanding of the impact of methane on global warming.
- Consider the use of non-methane hydrocarbon or reactivity based standards to recognize the emissions benefits of NGVs. Total hydrocarbon standards may no longer be appropriate.
- Implementation of training in the maintenance of NGVs at technical institutions as part of a plan to develop a service network.
- Consideration of long term government procurement practices to help create a testing ground and market for alternative fuelled vehicles including NGVs.